

Field Manual
UniSort IV[®] Sortation Conveyor
Installation Procedures, Maintenance, and
Parts Identification



To contact Intelligrated:

For service: Customer Service and Support (CSS)

Hotline 1-877-315-3400

On the World Wide Web: www.intelligrated.com

By mail:

Intelligrated
7901 Innovation Way
Mason, OH 45040

(513) 701-7300

Read these documents thoroughly before attempting to perform maintenance or repairs to the applicable Intelligrated conveyor system components or devices. Exercise extreme caution when working around moving and rotating conveyor equipment. Wear the proper clothing and safety equipment. DO NOT attempt to perform any maintenance until the equipment is de-energized, locked out and tagged out in accordance with established company procedures.

The information presented in these documents are correct at the time of publication. Intelligrated has made every effort to ensure that the information presented is correct and free from error. However, some errors or misprints may occur. Please contact Intelligrated with any corrections.

This document is copyrighted © 2010 by Intelligrated, all rights reserved. No Part of this manual may be reproduced and/or distributed to parties other than the customer and the customer's employees for whom it was originally produced.

The following terms are trademarks™ of Intelligrated; Accuglide™, BOSS™ UniSort™, EZ-set™. The following terms are registered trademarks® of Intelligrated; Accuzone®, UniSort®, E-Z Set®. Intelligrated® is a registered trademark.

Direct questions and comments concerning the information contained in this manual to:

Documentation Department
Intelligrated
7901 Innovation Way
Mason, OH 45040

Ph (513) 701-7300

Fax (513)701-7349

customerservice@intelligrated.com



Package Conveyors



 <p>Do Not Climb, Sit, Stand, Walk, Ride, or Touch the Conveyor at Any Time</p>	 <p>Do Not Perform Maintenance on Conveyor Until Electrical, Air, Hydraulic and Gravity Energy Sources Have Been Locked Out or Blocked</p>	 <p>Operate Equipment Only With All Approved Covers and Guards in Place</p>
 <p>Do Not Load a Stopped Conveyor or Overload a Running Conveyor</p>	 <p>Ensure That All Personnel Are Clear of Equipment Before Starting</p>	 <p>Allow Only Authorized Personnel To Operate or Maintain Material Handling Equipment</p>
 <p>Do Not Modify or Misuse Conveyor Controls</p>	 <p>Keep Clothing, Body Parts, and Hair Away from Conveyors</p>	 <p>Remove Trash, Paperwork, and Other Debris Only When Power is Locked Out and Tagged Out</p>
 <p>Ensure That ALL Controls and Pull Cords are Visible and Accessible</p>	 <p>Know the Location and Function of All Stop and Start Controls</p>	 <p>Report All Unsafe Conditions Jams should be cleared ONLY BY Authorized, Trained, Personnel</p>

POST IN PROMINENT AREA

Field Manual Issue and Revision Date(s)

1st Issue	December 2003
1st Revision	February 2006
2nd Revision	December 2006
3rd Revision	October 2007
4th Revision	August 2011

Field Manual Revision Summary

Revision Date	Manual Section(s)	Revision Summary
October 2007	Section H	Page H-5 - updated Figure H-1 and Table H-2
		Page H-5 - changed Belt C - 1/4" x 15 1/4" to Belt C - 1/4" x 15 3/4"
		Page H-8 - changed Belt E - 1/4" x 17 1/2" to Belt E - 1/4" x 20 1/4"
		Page H-9 - changed Belt G - 1/16" x 6 1/2" to Belt G - 1/4" x 6 1/8"
	Section I	Page 1-2 - updated Figure I-1
		Page 1-3 - updated Figure I-2
		Page 1-4 - updated part numbers
		Page 1-5 - updated part numbers
		Pages 1-12 thru 1-21 - updated part numbers
August 2011	Section H	Page H-5 update part numbers. Page H-8 update size for Belt D1 and Belt D2.

Field Manual Issue and Revision Date(s) -----	1 - 4
Field Manual Revision Summary -----	1 - 4
Section G Installation Procedures	
Introduction -----	G - 1
Accepting Shipment -----	G - 1
Shortages or Errors -----	G - 1
Lost or Damaged Shipment -----	G - 1
Claims and Returns -----	G - 1
Codes and Standards -----	G - 1
Warning Signs -----	G - 2
Safety Features -----	G - 2
Parts Replacement -----	G - 2
Factory Assistance -----	G - 2
Installation Overview -----	G - 3
Installation and Assembly Steps -----	G - 3
Installing the Conveyor -----	G - 5
Installing Floor Supports to Diverters -----	G - 5
Installing Floor Supports to End Drive, End Take-up, and End Idler Units -----	G - 6
Installing Floor Supports to Center Drive -----	G - 7
Installing Ceiling Hangers -----	G - 7
Installing Diverters -----	G - 7
Installing Center Drive Unit -----	G - 8
Installing Terminal Ends -----	G - 8
Installing Powered Belt on Roller Intermediate Section -----	G - 8
Installing Take-Away Conveyors -----	G - 11
Installing the Powered Carrying Belt -----	G - 13
Locating Return Belt Snub Rollers -----	G - 13
Return Belt Angle -----	G - 13
Return Belt Support Bracket with Roller -----	G - 14
Take-Up Pulley Initial Adjustment -----	G - 15
Threading the Belt -----	G - 19
Belt Cutting Procedure -----	G - 19
Belt Lacing Procedure -----	G - 19
Installing Air Piping and Connections -----	G - 20
Installing Drive Motor Soft Start -----	G - 21
Installing Electrical/Control Devices -----	G - 22
Installing Electrical Power and Control Device Wiring -----	G - 23
Initial Soft Start Adjustments -----	G - 24
Verifying Correct Drive Motor Rotation -----	G - 24
Initial Belt Tensioning and Tracking Adjustments -----	G - 24
Belt Tracking Adjustments -----	G - 25
Principles of Belt Tracking -----	G - 25
Final Adjustments -----	G - 27
Installing Product Containment Guarding -----	G - 28
Installing Personnel Safety Guards -----	G - 29
Final Soft Start Adjustments -----	G - 29
Drive Over-current Relay/Sensor Adjustments -----	G - 29
Air Pressure Adjustment -----	G - 29

Air Pressure Switch Adjustment	G - 29
Final Testing	G - 30
Checking Safety Features	G - 31
Installing Product Containment Guarding	G - 31
Installing Personnel Safety Guarding	G - 31
Final Installation Adjustments	G - 31
After Applying Electrical Power	G - 31

Section H Maintenance

Introduction	H - 1
Daily Inspections	H - 3
Weekly Inspections	H - 3
Monthly Maintenance	H - 4
Quarterly - 500 Hours Maintenance	H - 4
Semi-Annual; 1000 Hours Maintenance	H - 4
Belt and O-Ring Replacement for the Diverter Mechanism	H - 5
Belt A - 3/16" x 12"	H - 6
Belt B - 1/4" x 15 3/4"	H - 6
Belt C - 1/4" x 15 3/4"	H - 7
Belt D1 - 1/4" x 20 1/4"	H - 8
Belt D2 - 1/4" x 20 1/2"	H - 8
Belt E - 1/4" x 20 1/4"	H - 8
Belt F - 1/4" x 20 1/4"	H - 9
Belt G - 1/4" x 6 1/8"	H - 9
Belt H - 640-8M-30 HTD	H - 9
Belt I - 1/16" x 3/4" x 22 1/2"	H - 10
Belt J - 1/16" x 5 3/8"	H - 10
Adjustments	H - 11
Troubleshooting Belt Problems	H - 14

Section I Parts identification

General Information	I - 1
Diverter Unit	I - 2
Diverter Spare Parts, Non-width Related	I - 4
Diverter Spare Parts Width Related (Conveyor Width)	I - 5
Diverter Belt Rollers	I - 5
Diverter Belt Roller Parts, Width Related	I - 7
Diverter Belt Roller Parts, Non-width Related	I - 7
Parts Not Illustrated	I - 8
Nondivert Sorter Modules	I - 8
Drive Components	I - 11
Drives Located at a Diverter Unit	I - 11
Single Drive	I - 11
Dual Drive	I - 11
Drives at Other Locations	I - 11

Single Drive, 1 Horsepower -----	- 12
Single Drive Diverter (RH & LH), 1 Horsepower -----	- 12
Single Drive, 1.5 Horsepower -----	- 13
Single Drive, 2 Horsepower -----	- 14
Single Drive, 3 Horsepower -----	- 15
Single Drive, 5 Horsepower -----	- 16
Single Drive, 7.5 Horsepower -----	- 17
Dual Drive, 2 Horsepower -----	- 18
Dual Drive, 3 Horsepower -----	- 19
Dual Drive, 5 Horsepower -----	- 20
Dual Drive, 7.5 Horsepower -----	- 21
Dual Drive, 10 Horsepower -----	- 22
Dual Drive, 15 Horsepower -----	- 23

SECTION G: INSTALLATION PROCEDURES

Introduction

Accepting Shipment

Immediately upon delivery, check that all equipment received agrees with the bill of lading or carrier's freight bill. Any shipping discrepancy or equipment damage should be clearly noted on the freight bill before signing.

Shortages or Errors

Report any shortages or errors to the Manufacturer's Customer Service in writing within ten (10) days after receipt of shipment.

Note: It is very important that you compare the Order Acknowledgment against the actual material received when you receive the shipment so you have enough lead time to order any missing parts. If you find that a part is missing during assembly, you may have to discontinue assembly while you wait for the part to arrive.

Lost or Damaged Shipment

Report lost shipments to the Manufacturer's Shipping Department.

If shipping damage is evident upon receipt of the conveyor equipment, note the extent of the damage on the freight bill and immediately contact the transportation carrier to request an inspection. Do not destroy the equipment crating and packing materials until the carrier's agent has examined them. Unless otherwise agreed by the manufacturer, the Purchaser (User) shall be responsible for filing claims with the transportation carrier. A copy of the inspection report along with a copy of the freight bill should be sent to the Manufacturer's traffic department.

Claims and Returns

All equipment furnished in accordance with the Manufacturer's Agreement is not returnable for any reason except where authorized in writing by the Manufacturer. Notification of return must be made to the Manufacturer's Customer Service Department, and if approved, a "Return Authorization Tag" will be sent to the Purchaser (Users). The return tag sealed in the "Return Authorization Envelope" should be securely affixed to the exterior surface on any side of the shipping carton (not top or bottom), or affixed to any smooth flat surface on the equipment, if not boxed.

Send authorized return shipment(s) transportation charges prepaid to the address indicated on the Return Authorization Tag. If initial shipment is refused, the Purchaser (User) shall be liable for all freight charges, extra cost of handling, and other incidental expenses.

Codes and Standards

The conveyor equipment is designed and manufactured to comply with the American National Standard Institute's "SAFETY STANDARDS FOR CONVEYORS AND RELATED EQUIPMENT" (ANSI B20.1) and with the National Electrical Code (ANSI/NFPA70).

The Purchaser/Operator shall be familiar with, and responsible for, compliance with all codes and regulations having jurisdiction regarding the installation, use, and maintenance of this equipment. Appropriate lockout/tagout policy and procedures shall comply with the minimum

safety requirements outlined in the American National Standard Institute's current publication (ANSI Z244.1).

Warning Signs

Warning signs and labels posted on or near the conveyor equipment shall not be removed, painted over, or altered at any time. All safety devices, warning lights, and alarms associated with the conveyor system should be regularly tested for proper operation and serviced as needed. If the original safety item(s) become defective or damaged, refer to the conveyor parts list(s) or bill(s)-of-materials for replacement part numbers.

Safety Features

- DO turn off conveyor power source(s) and affix appropriate lockout/tagout device(s) to operating controls before servicing the equipment. ONLY trained and qualified personnel who are aware of the safety hazards should perform equipment adjustments or required maintenance while the conveyor is in operation.
- DO observe all warning signs, lights, and alarms associated with the conveyor operation and maintenance, and be alert at all times to automatic operation(s) of adjacent equipment.
- DO use extreme caution near moving conveyor parts to avoid the hazard of hands, hair, and clothing being caught.
- DO NOT sit on, stand on, walk, ride, or cross (over or under) the conveyor at any time except where suitable catwalks, gates, or bridges are provided for personnel travel.
- DO NOT attempt to repair any equipment while the conveyor is running, replace any conveyor component without appropriate replacement parts, or modify the conveyor system without prior approval by the manufacturer.
- DO NOT operate the conveyor until all safety guards are securely in place, all tools and non-product materials are removed from or near the conveying surfaces, and all personnel are in safe positions.
- DO NOT remove or modify any safety devices provided on or with the conveyor.
- DO NOT clear jams or reach into any unit before first turning off the equipment power source(s) and affixing appropriate lockout/tagout device(s).

Parts Replacement

To minimize production downtime, selected conveyor spare parts should be stocked for replacement of defective components when required. Refer to the equipment bill(s)-of-materials where quantity requirements or code numbers are not indicated on the conveyor parts list. A list of selected spare parts for standard products is included in this manual (see Section I).

Factory Assistance

Contact Field Service for installation, operation, or maintenance assistance, or Customer One Protection (COP) for replacement parts.

Installation Overview

This topic presents a recommended order for installation, final assembly, and alignment verification of the UniSort IV Sortation Conveyor. The remainder of this section provides detailed information.

The layout/installation drawings that should be referenced include:

- UniSort IV layout drawings that show type, location, and elevation of the UniSort IV sections and associated conveyors.
- Air piping/air connection drawing(s).
- Electrical layout drawing(s).

Installation and Assembly Steps

1. Verify receipt of the correct types and quantities of UniSort IV sections, installation hardware, loose parts, take-away conveyors, etc. as shown on the installation/layout drawings.

Note: The parts that are typically shipped loose include: carrying chains, carrying tubes (slats), divert pushers, air filter/regulator/lubricator, air pressure switch, variable speed controller, any additional air lubricators, supports, guardrail, PTO components (if applicable), chain track, and track splice joints.

2. Mark the Layout - Refer to the layout drawing(s) and mark the location and centerlines of the UniSort IV onto the floor or mezzanine. Perform this for each UniSort IV section and all associated infeed, discharge, and take-away conveyors shown on the layout drawing(s).
3. Pre-install Floor Supports and Ceiling Hangers.

Note: If the conveyor is to be located on an elevated structural steel platform, the platform should be in place and level along its entire length and width before installing any UniSort IV section see Product Manual 5310 *Floor Supports and Ceiling Hangers*.

4. Install Diverter.
5. Install Center Drive (if used).
6. Install Terminal Ends (can include End Take-up, End Drive, Idler Sections).
7. Install Powered Belt on Roller Intermediate Sections.
8. Install Intermediate Section(s) Floor Supports (if used).
9. Verify correct installation of all pre-assembled units. Pay special attention to verifying that the correct type of UniSort IV diverter unit is installed in the location specified by the layout drawing.
10. Check alignment and leveling of all installed units.
11. Install Take-Away Conveyors.
12. Install UniSort IV main line carrying belt.
13. Install Return Belt support bracket and roller (if used).
14. Install Air filter-regulator-gauge and Air Pressure Switch.
15. Install Air Piping. Make air connections.
16. Install Drive Motor Soft sSart(s).

-
17. Install Tracking Encoder(s) and Photo-Eyes.
 18. Install Control Panel(s) including Motor Starters, Relays, Fuses, Terminal Strips, Sorter Tracking Control Unit, etc.
 19. Install all Electrical Power and Control Wiring.
 20. Perform initial soft start adjustments. (Refer to Soft Start Manufacturers Manual.)
 21. Apply momentary power to drive motor(s) to verify correct rotational direction to drive motor(s).
 22. Perform initial main line belt tensioning and tracking adjustments.
 23. Perform final belt tracking adjustments.
 24. Perform final soft start adjustments. (Refer to Soft Start Manufacturers Manual.)
 25. Ensure proper adjustment of over-current electrical relays/sensors. (Refer to Manufacturers Instructions.)
 26. Set air pressure for 80 psi operating pressure.
 27. Check for correct height of all diverter unit pop-up wheels.
 28. Install product containment guard rail.
 29. Install personnel safety guards.
 30. Test run the completely installed UniSort IV with product being diverted. Make any necessary adjustments.

Installing the Conveyor

Installing Floor Supports to Diverters

See Product Manual 5310 *Floor Supports and Ceiling Hangers* for complete floor support installation instructions. The floor support information presented here provides additional information for the UniSort IV conveyors.

Pre-install the Floor Supports to each diverter before actually installing the diverters in place.

Note: The type FSM Floor Supports are used for the Diverters, End type Drives, Center type Drives, End Take-ups and Idler Section. Do not confuse with with FSMU4 type Supports used with Intermediate Sections only.

As shown in Figure G - 1, pre-installed two (2) FSM Type Floor Supports to each Diverter. The Floor Supports are located at each corner. Adjust Floor Support height as required.

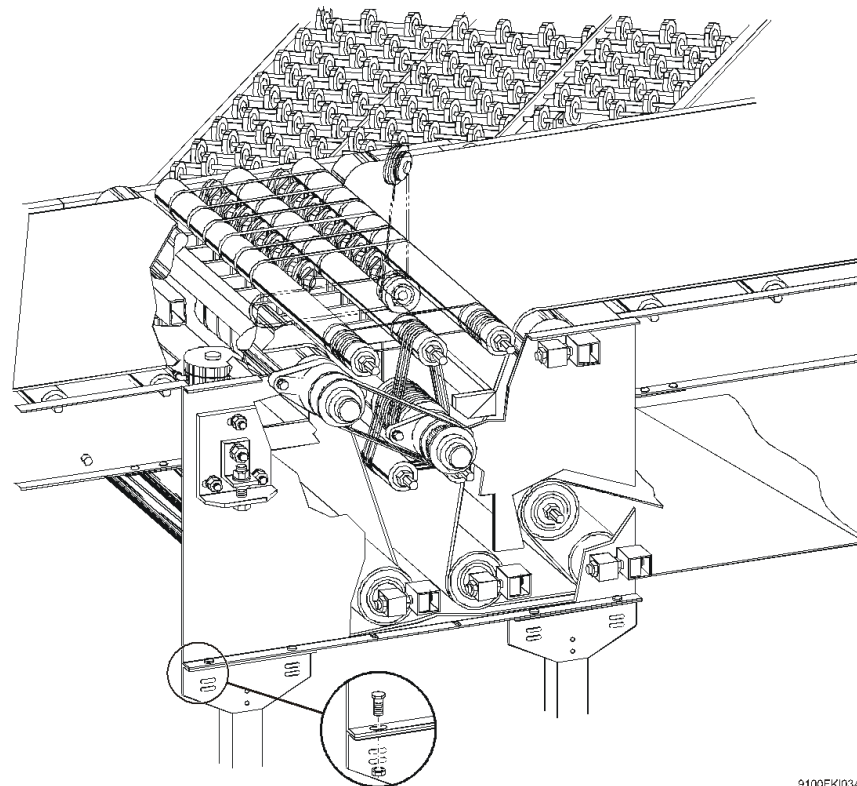

Figure G - 1 Installing Floor Supports to Diverter

9100FK1034a

If a Dual Drive or Single Drive with Diverter is included in the layout, a single leg FSM Floor Support is used to support the Drive Motor Mounting Plate. This support is in addition to floor supports mounted at each corner of the Diverter. Install the Single Leg Support as shown in Figure G - 2. Adjust height as required.

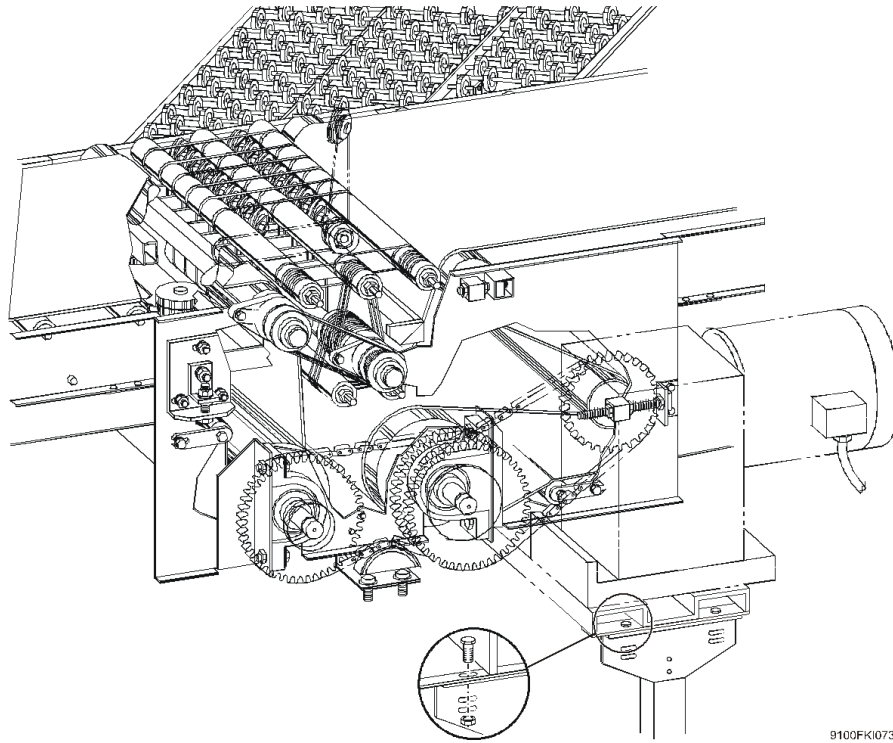
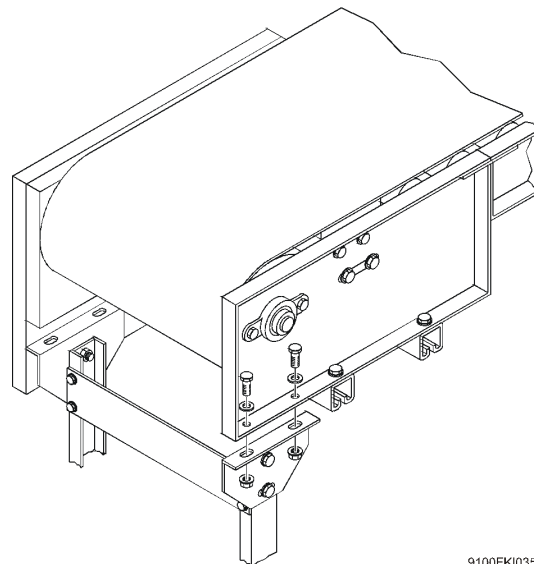

Figure G - 2 Single Leg Floor Support on Drive Motor Mounting Plate

Installing Floor Supports to End Drive, End Take-up, and End Idler Units

Type FSM Floor Supports are to be pre-installed to the 800 Series End Drive, End Take-up and End Idler units as shown in Figure G - 3.



End Drive Unit shown,
Power Unit not shown.

Figure G - 3 Floor Supports Mounted to Terminal End

Installing Floor Supports to Center Drive

The 800 Series Center Drive does not typically require floor supports.

Installing Ceiling Hangers

If Ceiling Hangers are to be used, the hangers should be pre-installed to the overhead structure of the building. See Product Manual 5310 *Floor Supports and Ceiling Hangers* for complete ceiling hanger installation instructions.

Installing Diverters

The Diverter units are to be set in place after the Floor Supports or Ceiling Hangers have been pre-installed.

CAUTION: There are six different types of UniSort IV Diverter units. Verify that the correct Diverter type is set in place as shown by the layout drawings.

Set the Diverters in place ensuring correct Diverter type, location and elevation. Align all Diverter units carefully before final fastening to floor, etc. Locate the Return Belt Snub Roller in all End Diverter units as shown by the installation drawing and as identified in Figure G - 4.

Note: Snub Roller located on side where Return Belt travels "UP".

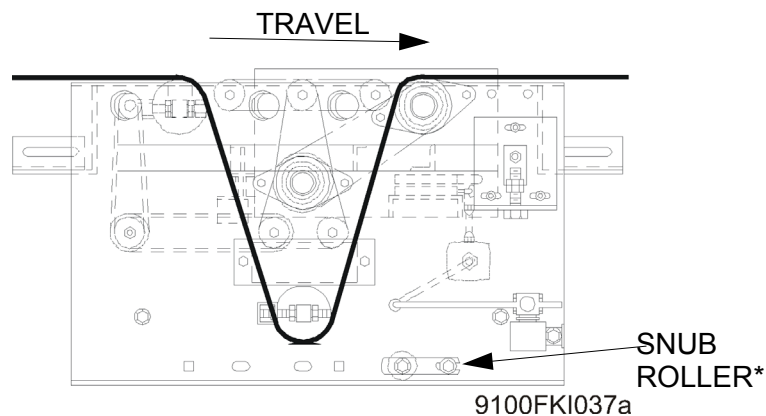

*Located on upstream or downstream side depending on layout.

Figure G - 4 End Diverter - Snub Roller Location

Installing Center Drive Unit

Set the 800 Series Center Drive unit, if used, in place as shown by the layout drawing. Refer to Figure G - 5 for correct installation of the Center Drive unit. Note location of Power unit with respect to direction of travel.

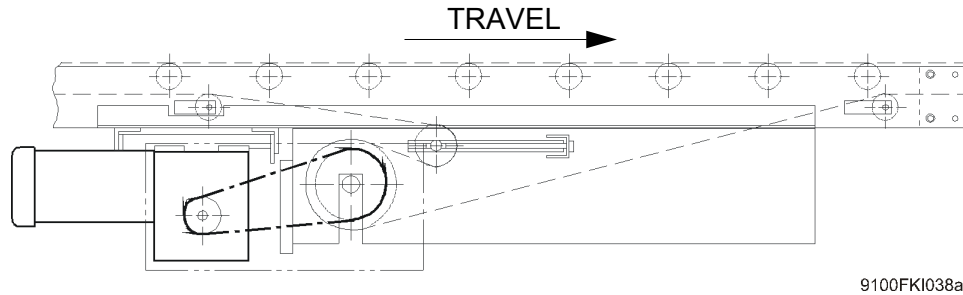

Figure G - 5 800 Series Center Drive Unit

Installing Terminal Ends

Identify and set the Terminal Ends in place. Terminal Ends include 800 Series End Drive (if used), End Take-up(s), Idler section(s). Verify correct Terminal End type, location, and alignment before final fastening to floor or to ceiling hanger.

Installing Powered Belt on Roller Intermediate Section

Install the Powered Belt on Roller Intermediate section (PBR-IS) starting at the infeed end. The Layout drawing shows the length of the different Intermediate sections to be installed. The identification labels also show the length.

PBR Intermediate sections are installed after Diverter units and Terminal Ends have been fully installed. End, Intermediate, Dual Snub, Take-up Idler interface, and Single Drive with Diverter have the same mounting for PBR Intermediate sections (Figure G - 6). The Dual Drive with Diverter uses a different mounting. It may also be necessary to field cut the PBR-IS before final installation of each individual section. Verify Intermediate section length before cutting.

A Splice Flat is used to connect together two PBR-IS as shown in Figure G - 7. A Splice Angle may also be used for retaining the load carrying capability.

Type FSMU4 floor supports are installed on PBR-IS are more than ten (10) feet long or when two sections are spliced together. See Product Manual 5310 *Floor Supports and Ceiling Hangers* for complete floor support installation instructions.

CAUTION: Ensure that type FSMU4 floor support is used for the PBR-IS. Only this floor support provides adequate side clearance for return run of this belt.

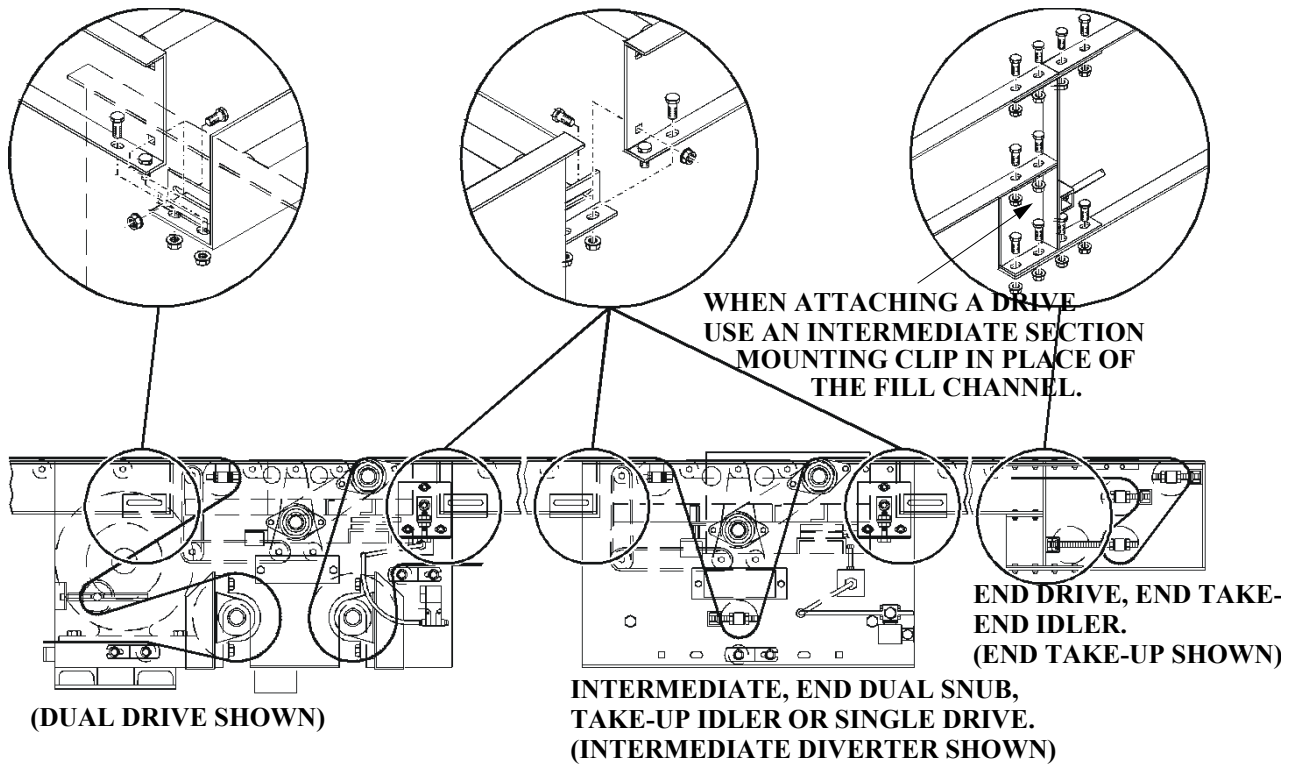

9100FK1039a

Figure G - 6 Installing Intermediate Sections

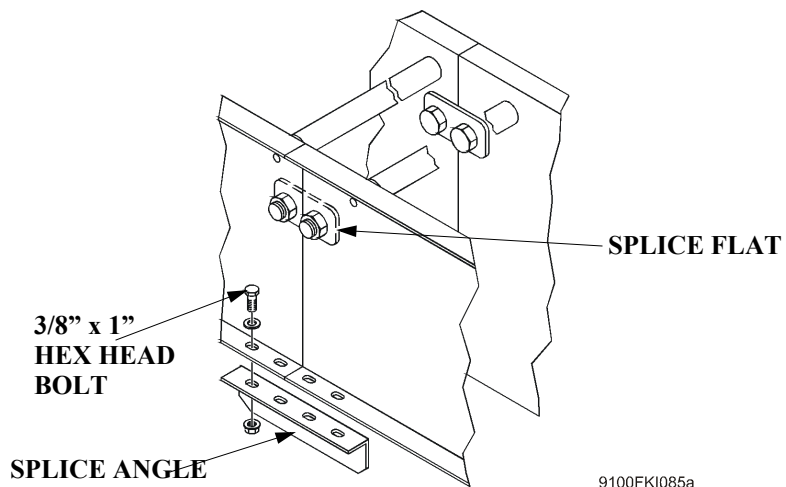

9100FK1085a

Figure G - 7 A Splice Flat Connection

Check for correct installation and alignment of pre-assembled units before proceeding:

1. Includes Diverter units, Terminal Ends, Intermediate sections, Floor Supports/Ceiling Hangers.
2. Refer to Layout Drawing.
3. Verify that all Diverter units are located correctly in terms of Diverter unit type and Drive unit horsepower of any Single or Dual Drive with Diverter units.
4. Verify correct installation of Terminal Ends (type and location) and of Center Drive (if used).
5. Check alignments carefully.

CAUTION: Any mis-alignments will affect belt tracking.

The following alignment checks should be performed:

1. Proper height of all Diverter units, Intermediate sections, and Terminal Ends.
2. All units are installed level. (No side to side tilt.)
3. No skew in the Intermediate sections.
4. Intermediate sections carrying rollers are on 8" centers not skewed.

Note: All Intermediate section return belt snub and idler rollers to be checked and located during belt installation.

Installing Take-Away Conveyors

Install Take-away conveyors to the divert side of all Diverter units. Figure G - 8 shows installation of the 45° Straight Gravity Wheel type Take-away conveyor. Figure G - 9 shows the location of Take-aways with respect to the Diverter.

Gravity Wheel Take-away conveyors should have a minimum 5/8" per foot pitch.

CAUTION: For reliable product diverting and conveying of diverted product, the Take-away conveyor must be located at the Diverter units as shown in Figure G - 9.

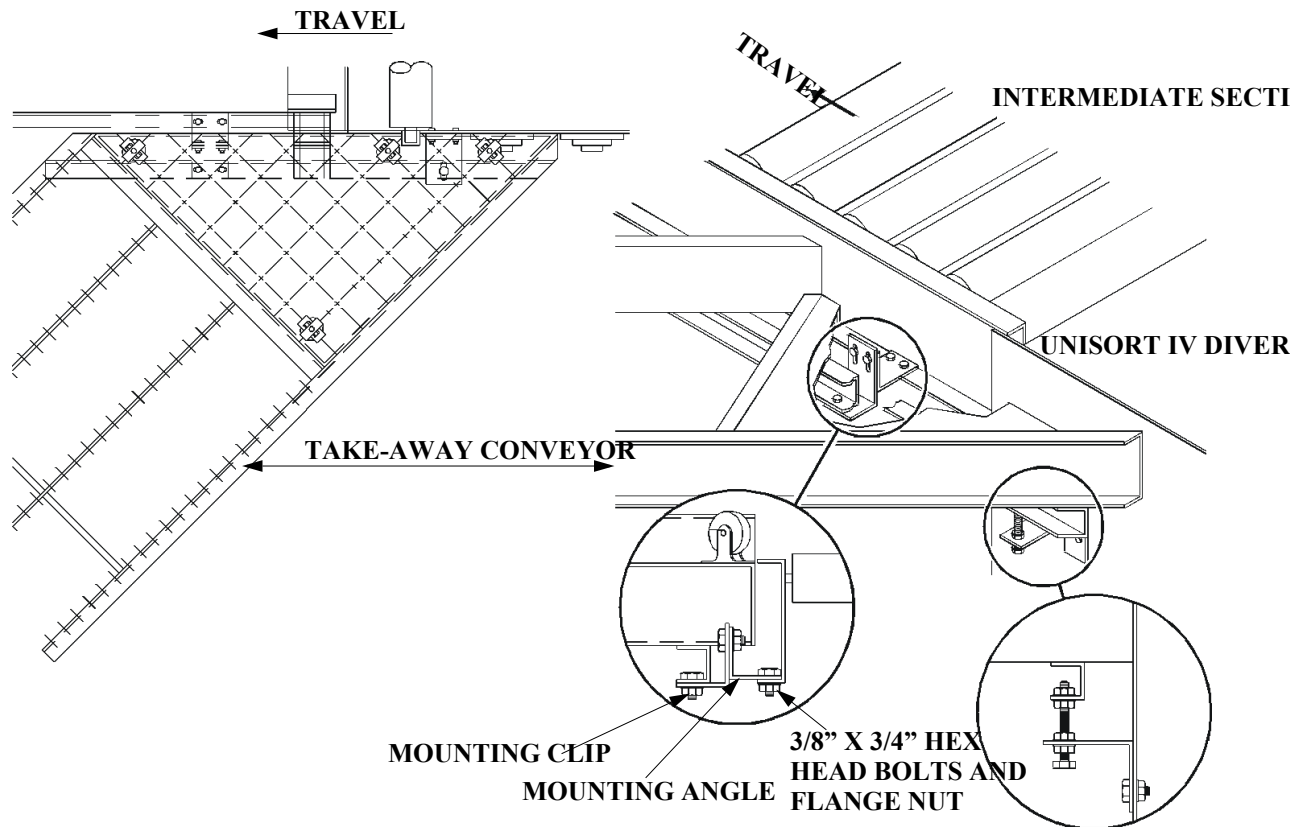

9100FKI041a

Figure G - 8 Take-Away Conveyor Mounting

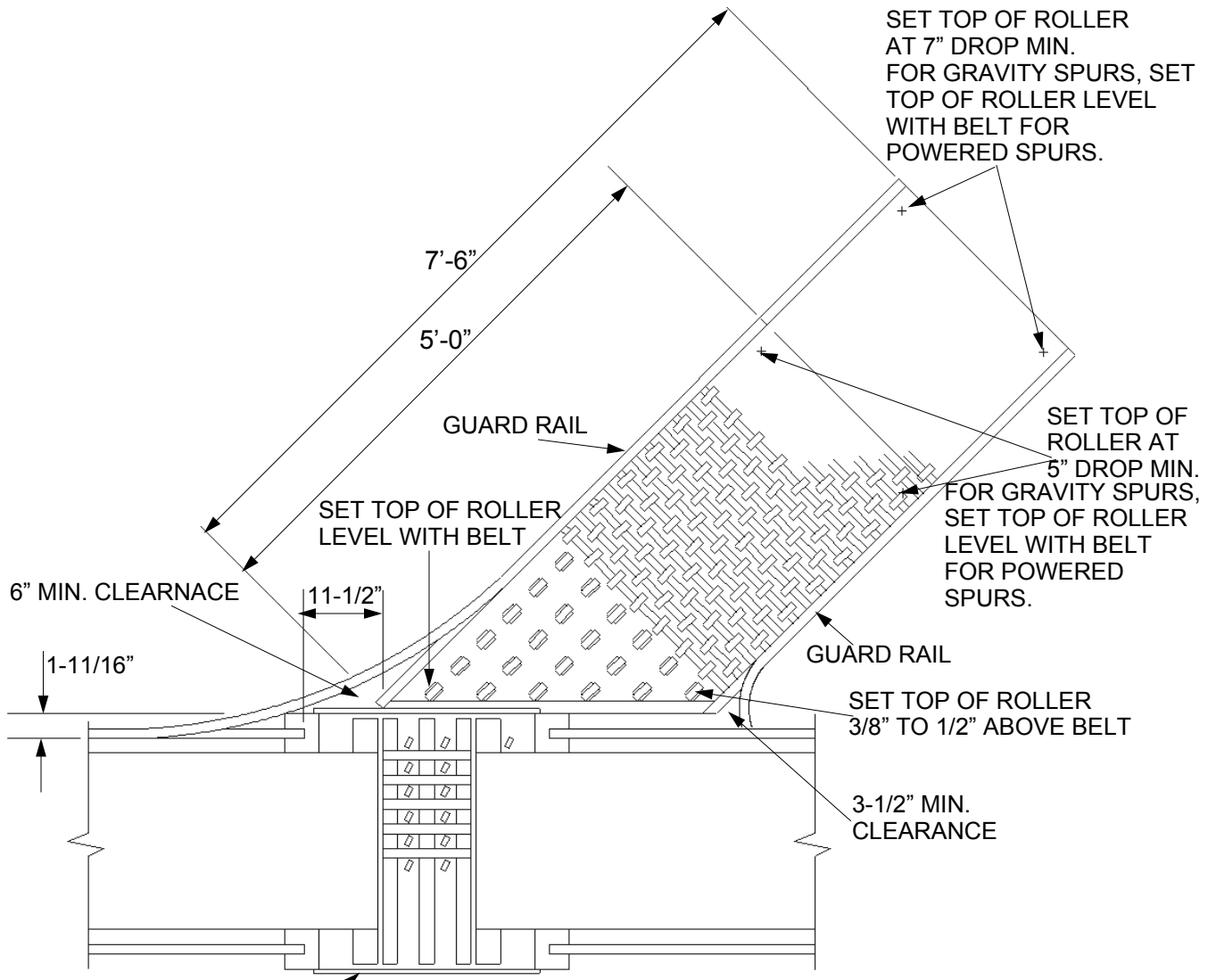

UNISORT IV DIVERTER ASSEMBLY
Figure G - 9 Take-Away Conveyor Location

9100FK1042a

Installing the Powered Carrying Belt

The procedure and order used for installing the powered belt consist of:

- Locating Return Belt Snub Rollers in End Diverters and Intermediate sections.
- Installing any required Return Belt Support Bracket with Roller.
- Initially adjusting all Take-up pulleys.
- Threading the belt.
- Cutting the belt square.
- Installing the clipper lacing.

Locating Return Belt Snub Rollers

The UniSort IV End Diverter is supplied with a Return Belt Snub Roller that must be field located based on the layout.

Refer to the layout drawing and verify that all the End Diverters have the Return Belt Snub Roller located on the side where the return belt is to travel up to an Intermediate section or to a Drive or Terminal End.

Return Belt Angle

The return belt angle is determined by Intermediate section lengths and placement of the Return Belt Snub Roller in the Intermediate section. Place all Return Belt Snub Rollers in the Intermediate sections to achieve a 45° or less return belt angle. This can be accomplished by having dimension “A” always greater than dimension “B” as shown in Figure G - 10.

Note: Intermediate section Return Belt Snub Rollers (251GHS) are shipped in the “Field Kit.” Return Belt Idler Rollers (G196GHS) are included with Intermediate sections.

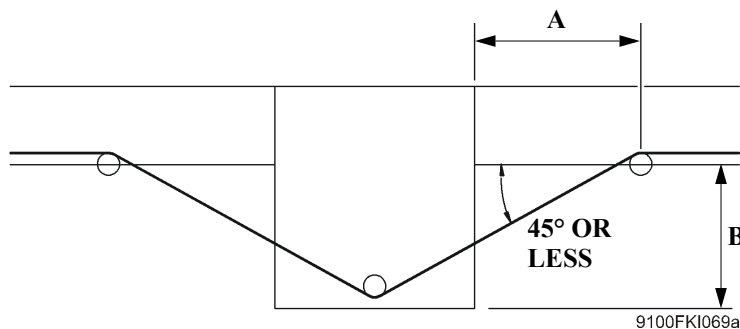

Figure G - 10 Return Belt Angle Example

Return Belt Support Bracket with Roller

The layout drawing shows the location of any applied UniSort IV Return Belt Support Bracket and Roller.

Refer to Figure G - 11 and install the Return Belt Support Bracket and Roller at locations indicated by the layout drawing.

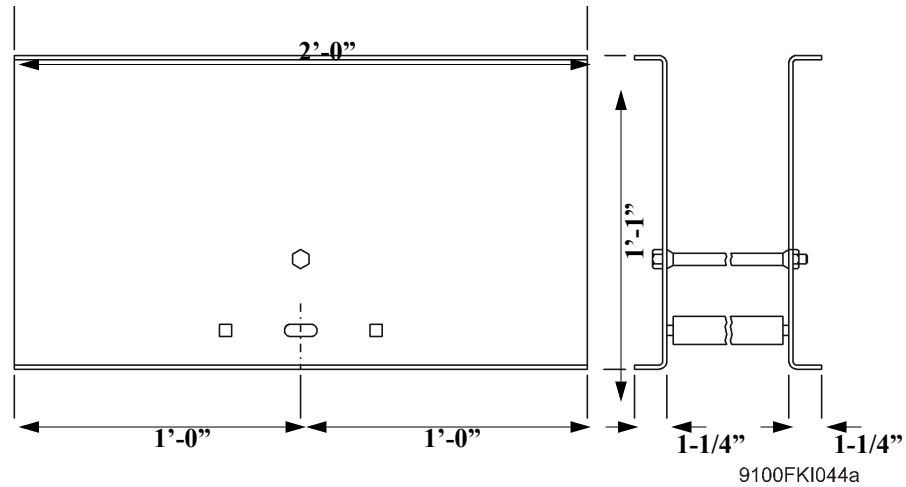

Figure G - 11 Return Belt Support with Roller

Take-Up Pulley Initial Adjustment

The Take-up Pulley should first be brought to within 1” of the position of minimum travel on the following units:

- Dual Drive w/Diverter unit
- Diverter w/Single Drive unit
- Take-up/Idler Interface units
- 800 Series Center Drive unit
- 800 Series End Take-up unit
- 800 Series End Idler unit

This is accomplished by turning the Take-up adjustment screws as shown in Figure G - 12, Figure G - 13, Figure G - 14, Figure G - 15, Figure G - 16, Figure G - 17, Figure G - 18, and Figure G - 19.

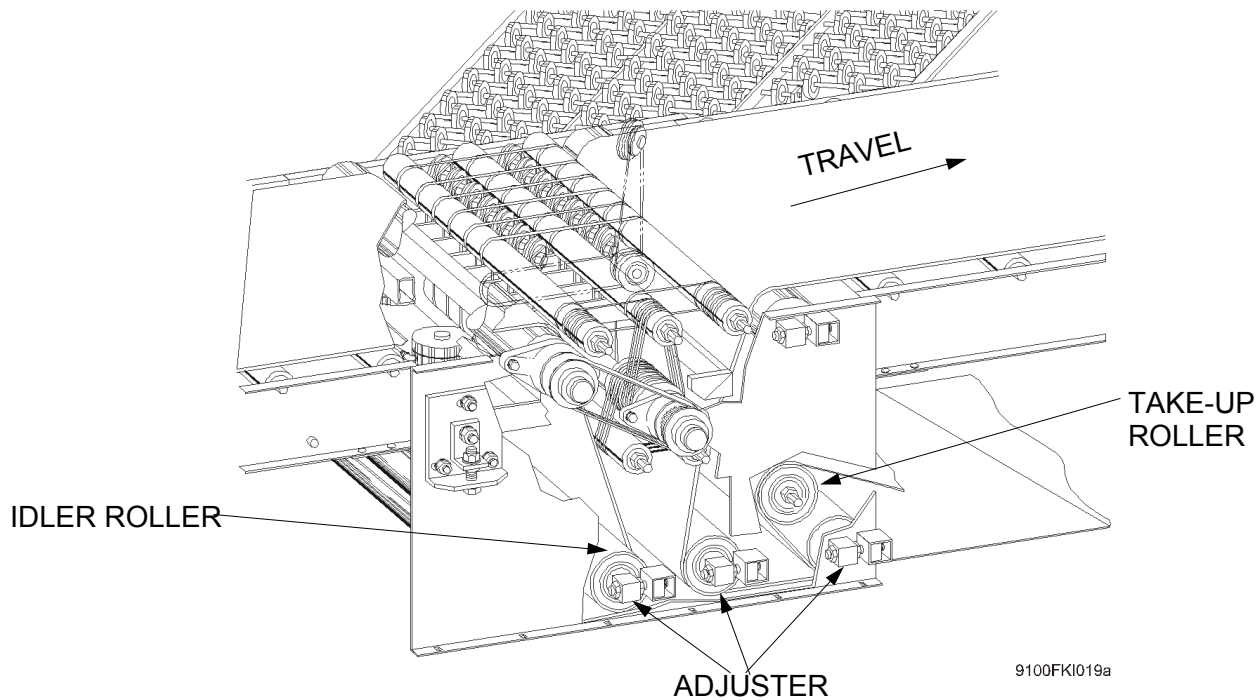

Figure G - 12 Take-up Idler/Interface Diverter

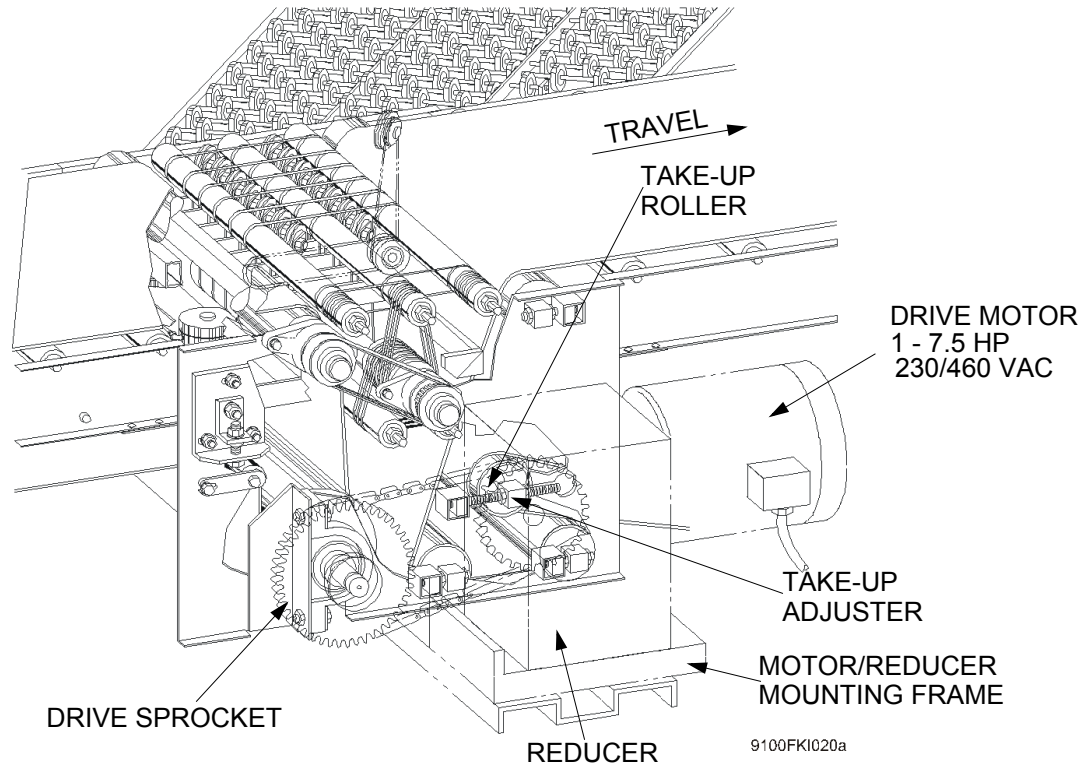

Figure G - 13 Diverter With Single Drive

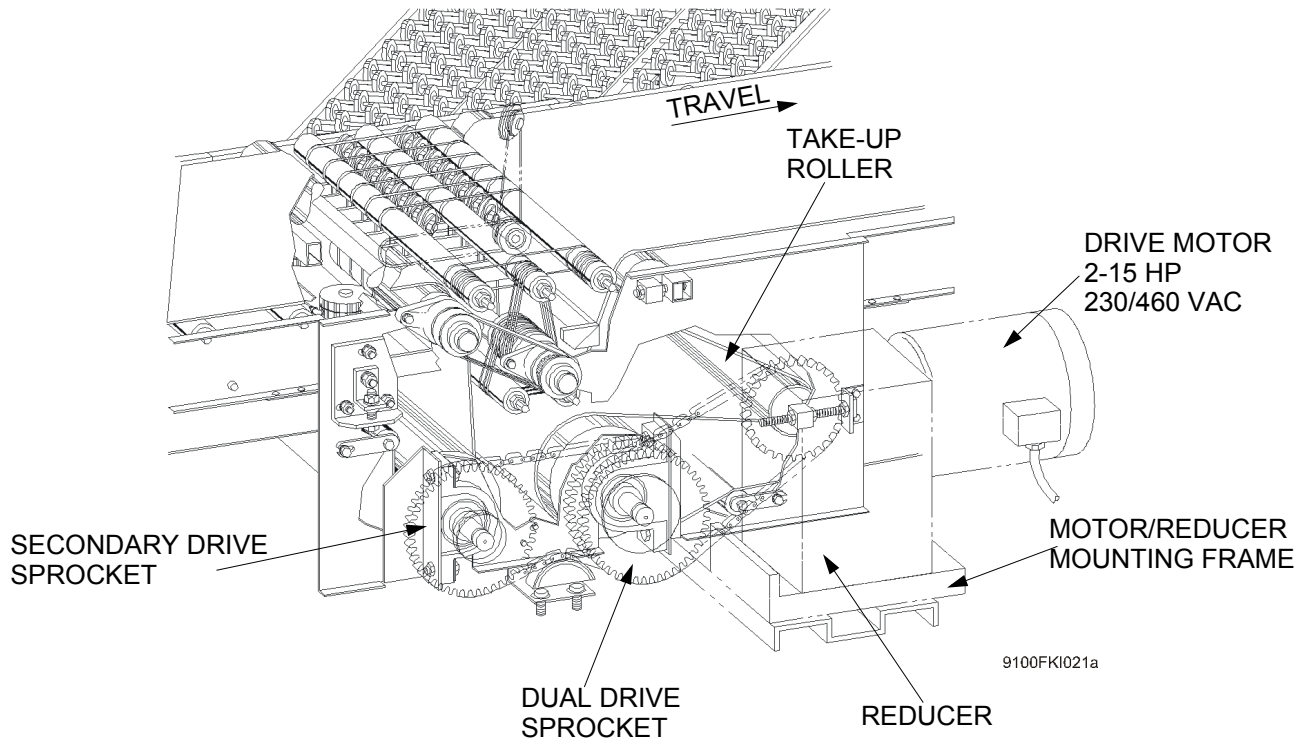

Figure G - 14 Diverter With Dual Drive

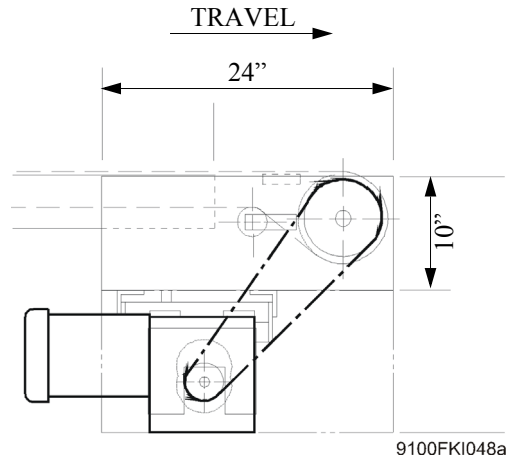

Figure G - 15 800 Series End Drive (Underhung Power Unit)

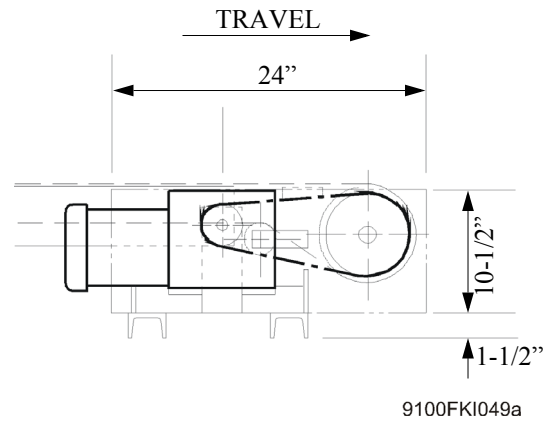

Figure G - 16 800 Series End Drive (Side Mounted Power Unit)

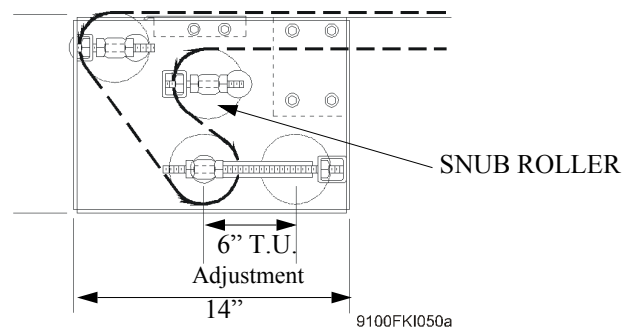

Figure G - 17 End Take-Up

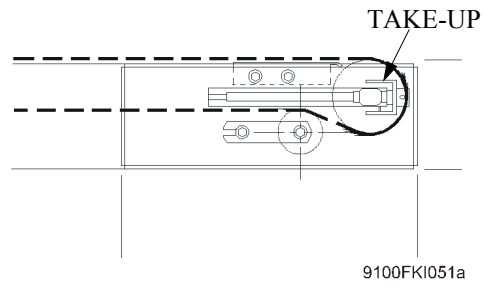

Figure G - 18 End Idler

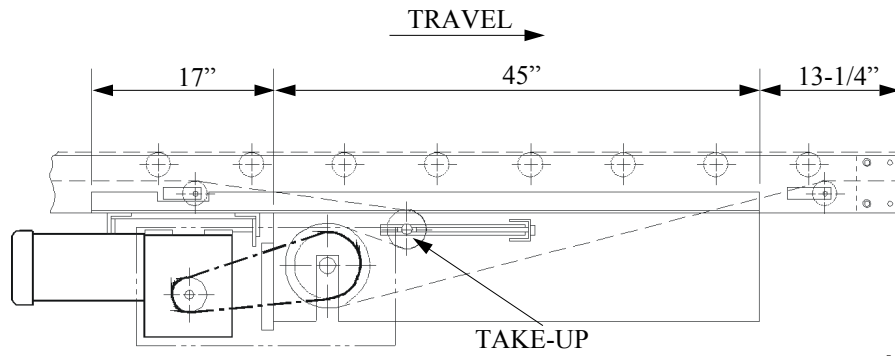

Figure G - 19 800 Series Center Drive

9100FKI052a

Threading the Belt

Refer to the layout drawing for determining the actual routing of the powered belt for your installation.

Note: The UniSort IV Dual Drive powers two belts. All other drive types power one belt. Drive belts are furnished in lengths to match the particular application. Verify correct belt length if more than one belt is to be installed and before threading the belt.

Starting at either end of the conveyor, thread the belt as shown in the layout drawing.

Pull the belt up and over the terminal end pulley(s) and bring the ends together on top of the bed as near to an End Idler/Take-up Pulley as possible. The belt is now ready to be cut and laced.

Note: Before cutting the belt, verify that the belt has been properly threaded through the various UniSort IV units.

Belt Cutting Procedure

Accurate squaring of the belt ends, prior to lacing, is excellent insurance against many common belt troubles. A properly squared belt tracks correctly and distributes stress evenly through the splice.

1. Always square from both sides of the belt (in case the sides are not parallel).
2. Draw the cut line, disregard the belt pattern which is not necessarily perpendicular to the belt edges.
3. Cut along the cut line using a straight edge and knife.

Belt Lacing Procedure

UniSort IV conveyors are furnished with Clipper brand belt lacings which require special lacing machines.

After cutting the belt square, stainless steel hooks are clinched into each end of the belt with a lacer machine. The ends are then brought together and the hooks are interconnected. A stainless steel connecting pin is then inserted through the joint, joining both ends of the belt together.

Should you experience any difficulties with the lacing or joining of the drive belt, please call for information.

This completes installation of the Powered Belt. Belt tensioning and belt tracking adjustments are to be done after installation of air piping and electrical power. For additional information, see the Product Manual 8100 *Powered Belt Conveyor*.

Installing Air Piping and Connections

To install the Air Piping:

1. Refer to your Air Piping layout drawing for Air Piping information. This drawing specifies the type, size, and location of air pipe and tubing as well as the location of the air filter/regulator/lubricator, air pressure switch, and any additional air lubricators. Figure G - 20 shows a typical UniSort IV Air Piping detail.

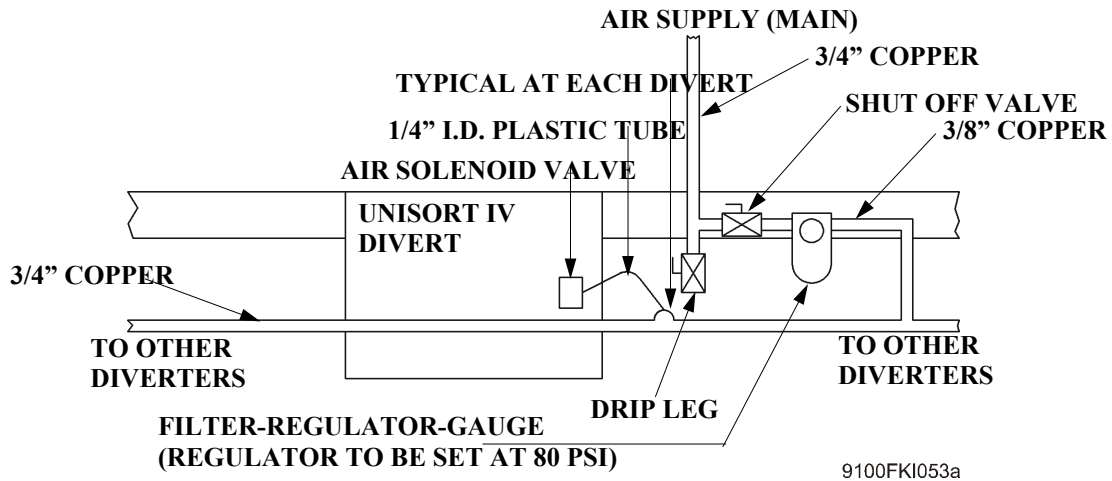

Figure G - 20 Air Piping Detail

2. Install the air filter/regulator/lubricator near or at the mid-point of the UniSort IV.
3. Adjust the regulator to 60 psi (side switch only) as indicated by the regulator gauge.
4. Depending on the UniSort IV layout, individual solenoid valve air lubricators may be required. Install these as shown on the Air Piping layout drawing.
5. Install the air pressure switch between the last and second last divert switch as shown in the figure. It is adjusted to “trip” whenever the air pressure falls below 50 psi.

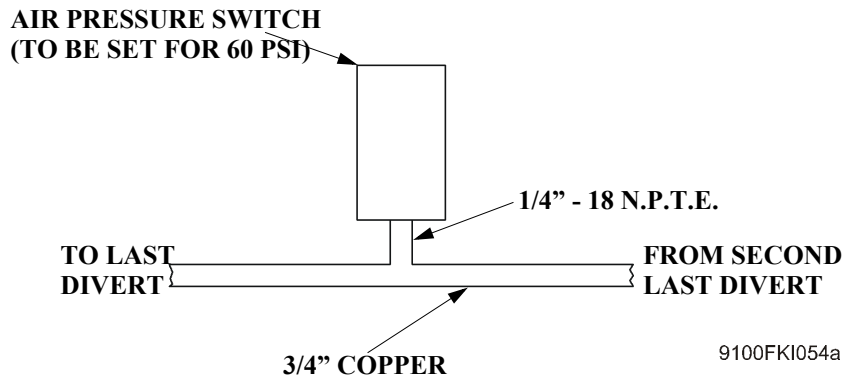

Figure G - 21 Air Pressure Switch Location

Installing Drive Motor Soft Start

A Soft Start is supplied for each UniSort IV drive motor. The soft start is mounted on the UniSort IV in an upright position and is close as possible to the drive motor. A minimum of six inch (6") clearance on top and bottom is required for adequate ventilation. Refer to electrical installation drawings and the Soft Start Manufacturer's Manual for specific mounting detail.

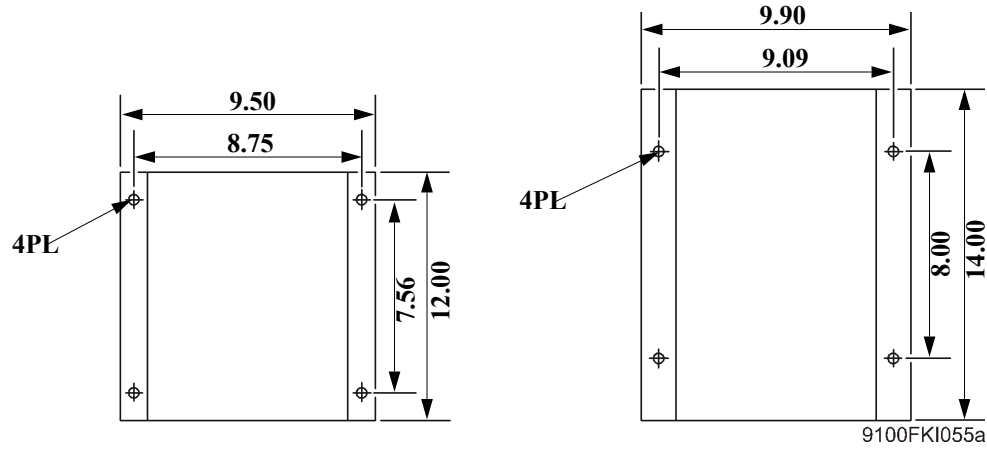

Figure G - 22 Soft Start Mounting Dimensions

Installing Electrical/Control Devices

Table G-1 shows the typical electrical/control devices that may be used for controlling a UniSort IV. Refer to the electrical installation drawings and materials list for the exact type, location, and wiring of each device used.

Table G-1 Electrical/Control Devices

Device	Function
Main Power Disconnect (may be 4-pole switch)	Switches power to the drive motor(s) and the control unit. The fourth pole switches power to the control unit. Located in the control panel.
Motor Starter(s)	Switches power to drive motor(s) via a motor disconnect switch and Variable Frequency Drive. Contact status may be supplied to control unit. Located in control panel.
Motor Disconnect	Switches power to the drive motor via the Variable Frequency Drive. The contact status is typically supplied to the control unit.
Soft Start	Effects smooth start-up acceleration of the drive motor. Typically wired between drive motor and motor disconnect switch. One Soft Start used per drive motor. Located on the UniSort IV.
Emergency Stop Push Button/Pull Cord	Used to drop power to the drive motor(s). The contact status is typically supplied to the control unit. Located on the UniSort IV.
Air Filter/Regulator/Gauge	Adjusted to supply filtered 80 psi operating air pressure for pop-up air cylinders. Connected to main air supply. Located on UniSort IV.
Air Solenoid Valve	110 VAC actuated valve for switching air to pop-up air cylinders for diverting. (Valve and air cylinder are supplied with each Diverter unit.) Located on each Diverter. NOTE: UniSort IV requires 80 psi air; pressure switch field adjusted to sense below 60 psi air pressure. Located on the UniSort IV.
Air Pressure Switch	Detects low operating air pressure. The contact status is typically supplied to the control unit.
Induction Photo-Eye(s)	Located on the UniSort IV. Detects the leading edge of product entering the UniSort IV so the product can be tracked. Photo-eye placed at upstream end (infeed end) of each UniSort IV belt section.
Lane Full Photo-Eye	Located on each take-away conveyor (sort lane) at the point where the take-away lane is considered full. Oriented at an angle so product is detected even if small gaps between product exists. Typically used with a 3-7 second delay timer. Lane is considered full if photo-eye remains blocked for that period of time. Product diverting to the lane is then inhibited.
Update Photo-Eye	Located on UniSort IV immediately upstream of each third Divert assembly. Use to adjust product tracking array in event product has slipped on the PBR belt.
Product Jam Detect Photo-eye	Located at extreme up-stream end of each Take-away (Sort Lane) conveyor. Oriented perpendicular to product flow direction. Used with 3-7 second time delay. Product jam condition indicated when product blocks entrance to Take-away conveyor for that period of time. Diverting to that lane is inhibited and power to the UniSort IV may be dropped.

Table G-1 Electrical/Control Devices

Device	Function
Tracking (Pulse) Encoder	<p>Used to measure (track) product moving along UniSort IV belt. A 4 pulse per revolution encoder is typically used to provide a tracking resolution of 2.5 inches.</p> <p>Encoder is attached to end of PTO pulley. End is supplied drilled and tapped to permit encoder installation.</p>

Installing Electrical Power and Control Device Wiring

Install wiring from the control panel to all electrical/control devices on the UniSort IV according to the electrical layout drawing. Figure G - 23 shows a typical UniSort IV drive motor wiring diagram.

Refer to the appropriate manufacturer’s instruction manual(s) for wiring Variable Frequency Drive(s), over-current relay(s), air pressure switch(es), and photo-eyes.

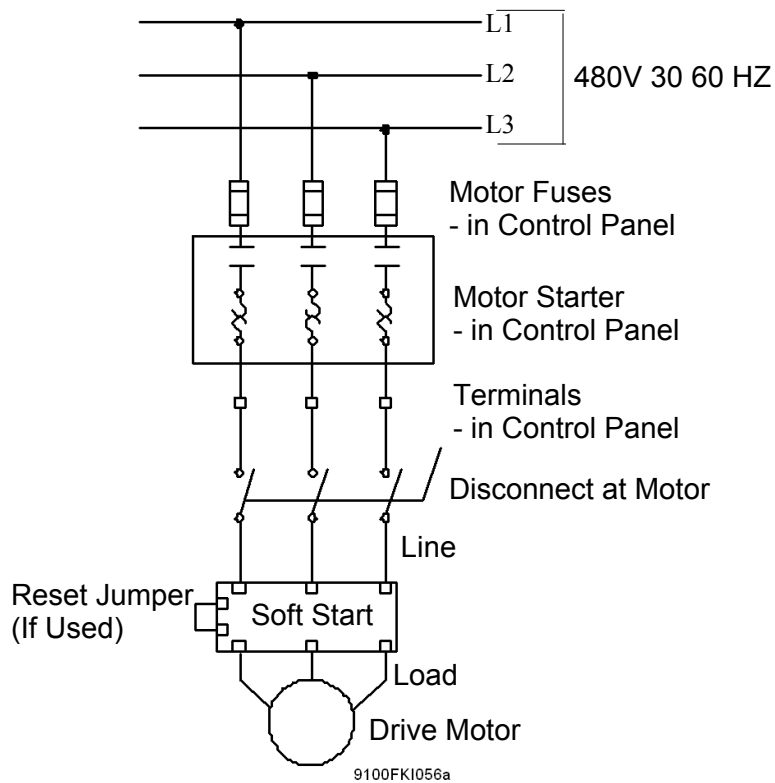

Figure G - 23 Unisort IV Drive Motor Wiring Diagram (Example)

Note: Soft starts to be mounted near motor. Refer to manufacturer’s instructions for actual wiring and adjustment procedure.

Initial Soft Start Adjustments

Refer to the *Soft Start Manufacturers' Instruction Manual* and perform any required adjustments prior to applying power.

Verifying Correct Drive Motor Rotation

CAUTION: Before applying power, review the safety check in **Before Applying Electrical Power** to ensure the safety of personnel.

1. Be sure the drive motor wiring is correct.
 2. Remove the V-belt drive.
 3. Apply momentary power to the drive motor(s) and check the direction of rotation.
 4. Re-install the V-belts.
-

CAUTION: A drive motor wiring error can result in reversed motor operation and/or possible drive motor damage.

Initial Belt Tensioning and Tracking Adjustments

Manually center the Belt as best as possible.

The belt is tensioned by adjusting the appropriate take-up pulley. Take-up Pulleys are used in the following units.

- 800 Series End Take-up (Figure G - 15)
 - 800 Series Center Drive (Figure G - 19)
 - 800 Series End Idler (Figure G - 18)
 - Dual Drive w/Diverter (Figure G - 13)
 - Single Drive w/Diverter (Figure G - 12)
1. For each belt used in the total UniSort IV Sorter layout, refer to the layout drawing and determine the type of unit in which the take-up pulley is located.
 2. Adjust the take-up pulley so that the belt tension is just tight enough to prevent belt slippage on the drive pulley. Adjust both sides of the take-up pulley equally and in 1/2 turn increments.
-

CAUTION: Excessive belt tension will reduce the life of the belt lacing, snub rollers and pulley bearings.

Belt Tracking Adjustments

Electrical power to the UniSort IV Drive Motor must be applied for initially checking and performing the belt tracking adjustments. For ensuring the safety of personnel and to minimize the possibility of damage to the UniSort IV, the following checks should be made before applying electrical power.

1. Check that the belt has been correctly threaded.
2. Check that the lacing connection has been securely made.
3. Check for proper and correct electrical connections. Verify power rotation of the drive motor.
4. Check that the soft start has been initially adjusted per the manufacturers instructions.
5. Check that the gear reducer in the power unit has the proper oil and oil level and the breather plug (if required) is correctly installed.
6. Check that all foreign objects are moved.

CAUTION: Belt tracking is most readily accomplished while the conveyor is running and must therefore be recognized as being dangerous. Only trained and qualified personnel should perform this adjustment. They must be instructed to always be alert for any unsafe condition and to use extreme care when tracking the belt.

Principles of Belt Tracking

Being able to successfully accomplish belt tracking is greatly dependent upon the alignment of all the UniSort IV Diverters and sections. Verify that all Diverters, Intermediate Sections and Terminal Ends are parallel to the center line of travel and are level side-to-side over the entire length of the UniSort IV.

Verify that all UniSort IV rollers and pulleys are at a right angle to the frame.

Verify that the belt is correctly tensioned so not to slip on the drive pulley. The belt is tensioned by adjusting the appropriate take-up pulley. Adjust each take-up pulley side the same amount. (See belt tensioning adjustments).

Crowned pulleys are used to help keep the belt on center. This is because belts tend to run toward the part of the pulley which is largest in diameter.

The belt will always creep toward the side where shaft centers are not exactly parallel and are the closest to each other. In the UniSort IV, only the snub rollers need to be adjusted to track the belt thus compensating for non-parallel pulley shafts. All adjustments should be slight with time allowed for the belt to react to the adjustment.

During product travel, if the belt creeps to the right on the tail pulley, adjust the right side of the snub roller in direction "R" and/or to the left side in direction "F".

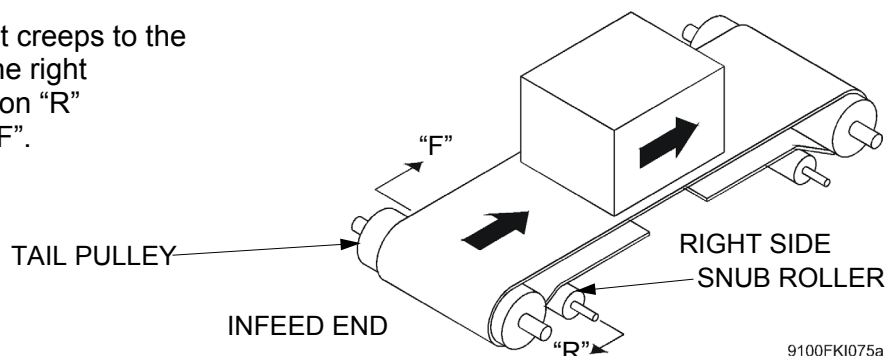

9100FKI075a

Figure G - 24 Belt Tracking Example

Note: The procedure is for each belt used in the UniSort IV Sortation Conveyor.

1. Verify that all safety checks have been performed
2. Verify that the conveyor has been correctly installed and aligned.
3. When performing first time belt tracking adjustments it is good practice to station a person at each 50 foot point of the UniSort IV length with one person at the infeed and discharge end.
4. Apply power to the conveyor and note where and to what side the top run of the belt moves toward. For first time belt tracking, concentrate only on tracking the top run of the belt.

Note: If there is any severe belt mis-tracking, turn power off immediately and recheck alignments.

5. Adjust the appropriate snub roller(s) as shown in Figure G - 12 through Figure G - 19. Start at the first mis-tracking point and work down the UniSort IV in the direction of travel.
6. Track the return run of the belt in the same fashion except start at the discharge end and work towards the infeed end.
7. Recheck all belt tracking adjustments. The belt is properly tracked when the edges of the belt are equidistant from the UniSort IV's side frames.
8. Recheck belt tensioning adjustments while causing the Diverter wheels to cycle up and down. Re-adjust appropriate take-up pulley as required.

Note: Always recheck belt tracking after making any belt tensioning adjustments.

Final Adjustments

1. Perform final Soft Start adjustments using procedure in Soft Start manufacturers manual.
2. Verify correct setting of Over-Current Relay / Sensor.
3. Verify air pressure is set for 80 PSI at the Air Filter/Regulator Gauge.
4. Verify low Air Pressure Switch is set to trip at 60 PSI
5. Check Diverter Unit pop-up wheel height adjustment.

The UniSort IV diverter wheel assembly pop-up height has been factory adjusted for the tops of the second row of wheels to extend 3/8" to 1/2" above the flat belts when in the pop-up position. (See Figure G - 25.)

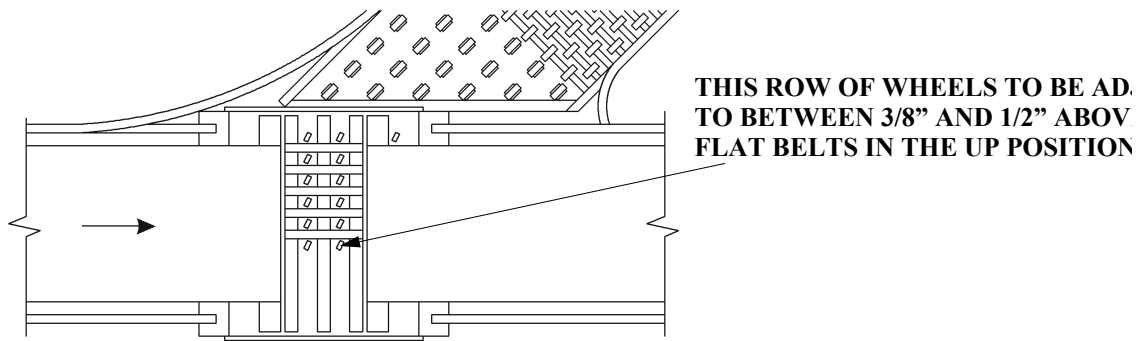

9100FKI076a

Figure G - 25 Adjusting the Diverter Wheels

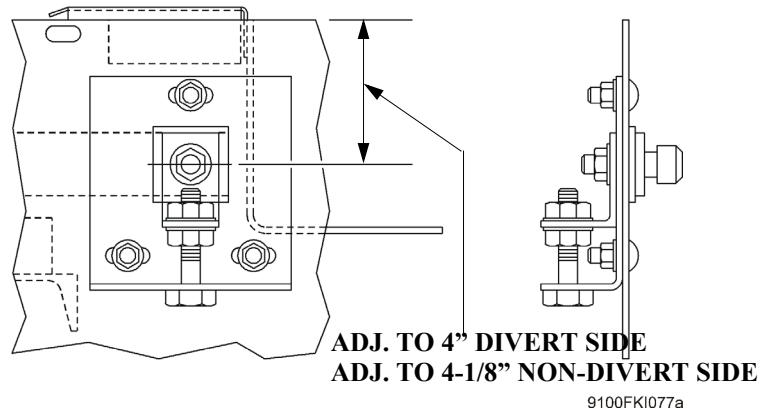

9100FKI077a

Figure G - 26 Pop-Up Wheel Adjustment

Using the following procedure if field adjustment is required:

1. Place the diverter pop-up wheel assembly in the "up" position. Requires 80 PSI Air and 110 VAC signal applied to the diverter's Air Solenoid Valve.
2. As shown in Figure G - 25 and Figure G - 26, use the height adjusters on the sides of the diverter unit to adjust.
3. Remove the 110 VAC signal and verify that the pop-up wheel assembly is in the "down" position and that the tops of all diverter wheels are below the flat carrying belts.

Installing Product Containment Guarding

The Product Containment Guarding is typically installed after all the installation adjustments have been made.

The UniSort IV uses two different types of guard rail:

- Type F, 5-1/2" high
- Type G, 11" high

In addition, 3 foot long section of notched guard rails are provided for mounting to the non-divert side of the UniSort IV Diverter. The notching allows clearance for the top rollers in each Diverter Unit, see Figure G - 28.

Refer to Figure G - 27 and Figure G - 28 for installing the guard rail.

Check the alignment of the vertical surfaces before final tightening of the bolts. Smooth joints will ensure trouble-free operation. Special attention should be paid to ensure that the guard rail on the divert side and at the divert points will not interfere with the diverting or smooth taking away of products.

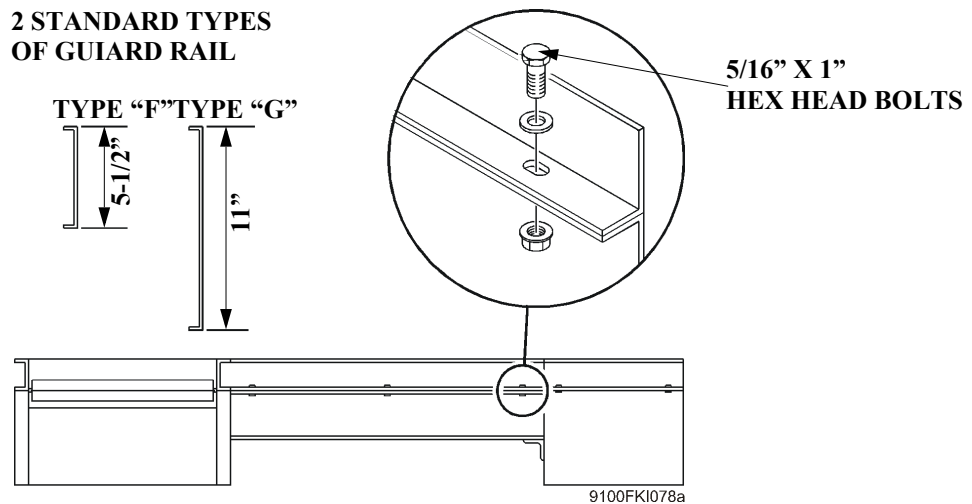

Figure G - 27 Installing Guard Rail

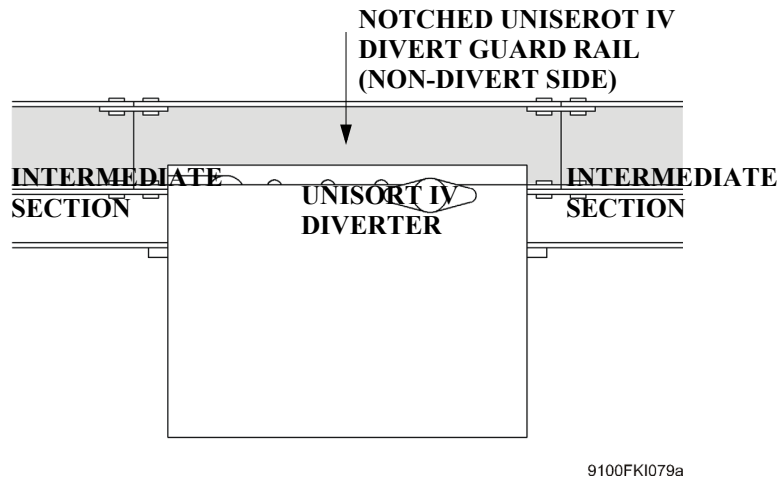
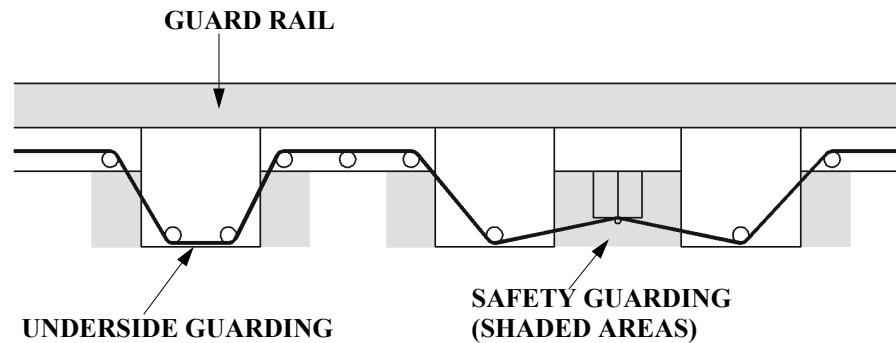

Figure G - 28 Notched Guard Rail

Installing Personnel Safety Guards

Personnel safety guarding is provided to prevent possible personal injury to any person coming into accidental contact with any moving part of the UniSort IV.

As shown in Figure G - 29, these areas include edge and bottom surfaces of the belt return run, pinch points, and diverter unit top and bottom surfaces.



9100FKI080a

Figure G - 29 Location of Personnel Safety Guards

Refer to the installation / layout drawing for installing the provided personnel safety guarding.

The UniSort IV Power Units are supplied with guards that fully enclose the sprocket drive chains. If any of these guards have been removed during installation, be sure they are re-installed before approving the installing for production.

Final Soft Start Adjustments

Refer to the *Soft Start Manufacturers' Manual* and perform final adjustments with power applied.

When the Soft Start is correctly adjusted, the UniSort IV will smoothly accelerate to operating speed with no jerking of the carrying chains.

Drive Over-current Relay/Sensor Adjustments

The drive over-current relay/sensor is adjusted to match the drive motor's starting current as listed on the motor's name plate. Refer to the manufacturer's instruction sheet for adjusting the over-current relay/sensor.

Air Pressure Adjustment

To set the air pressure, adjust the air regulator located on the UniSort IV. Set the air regulator to 60 psi (as indicated on the regulator gauge).

Air Pressure Switch Adjustment

The air pressure switch is set to actuate if the air pressure is 10 psi less than the required operating air pressure. Refer to the manufacturer's instruction sheet for adjustment instructions.

Final Testing

1. Test run the completely installed UniSort IV with product being diverted.
2. Check for smooth start-up of the UniSort IV when power is applied.
3. With product being diverted, verify that product is being smoothly and correctly diverted onto the correct take-away conveyors.
4. Be sure that installed guard rail will not result in product jams.
5. Check all safety devices to be sure they operate as designed.
6. Be sure that all safety labels are in place and guarding installed.
7. Ensure that the belt is properly tracked and does not come in contact with the “kicker” pop-up wheel in any of the Diverter units.
8. Make any necessary adjustments.

Checking Safety Features

Installing Product Containment Guarding

The product containment guarding is typically installed after all the UniSort IV installation adjustments have been made. For information on the installation of guarding, see the Product Manual 5320 *Side Guides*.

CAUTION: Be careful when installing the product containment guarding on the divert side. Be certain the guard rail does not interfere with the movement of diverted product.

Installing Personnel Safety Guarding

The personnel safety guarding prevents people from coming into contact with the moving parts.

To install personnel safety guarding refer to the installation/layout drawing because requirements vary by installation.

CAUTION: Personnel safety guards fully enclose the drive section V-belts (or drive chain). If these guards were removed during installation, reinstall them before approving the installing for production.

Final Installation Adjustments

CAUTION: Electrical power must be applied to perform the final checks. To ensure the safety of personnel and minimize the possibility of damage to the sorter, verify all of the following before applying electrical power.

After Applying Electrical Power

After applying electrical power:

1. Verify Soft Start adjustments following the manufacturer's instructions.

Note: When correctly adjusted, the Soft Start will allow the conveyor to smoothly accelerate to operating speed with no jerking of the carrying chains.

2. Observe the carrying belts, they should travel smoothly around each of the pulleys located in the drive section and the idler section.

CAUTION: If any adjustment is required, be sure the main electrical power switch is in a locked OFF position and tagged to prevent accidental application of electrical power.

3. Check the operation of all safety devices.

SECTION H: MAINTENANCE

Introduction

Recommended service checks and equipment maintenance are outlined in this section for typical, intermittent-duty conveyor applications. Additional maintenance and servicing schedule adjustments may be required for continuous-duty operation or extreme environmental conditions.

The indicated preventive maintenance time intervals are based on a UniSort IV which is operating eight hours per day in at or above freezing (40° F to 110° F) environmental temperatures.

All newly installed equipment should be frequently inspected and serviced as needed during the first 40 hours of operation; thereafter, an appropriate maintenance program should be established and followed (see Table G.1). The time intervals should be appropriately adjusted for more than eight hours per day operation and/or operation in a harsh environment. Also, sorting product that produces an extraordinary amount of dust, dirt or any other type of contamination may require more frequent preventive maintenance.

Maintaining separate service log sheets on each type of conveyor is recommended for plants operating more than one shift. Each log sheet should show dates, detailed inspection service information, and name or initials of person(s) performing the equipment inspection or service for future reference.

CAUTION: Before performing maintenance on a conveyor, make certain that the conveyor's power disconnect is locked in the "Open" position and tagged to prevent the accidental or unexpected application of power.

Do not perform maintenance while the conveyor is running unless specifically instructed to do so in this manual.

Note: Other than checking of chain tension, it is NOT necessary to have the conveyor turn ON to perform any of the work described in this section.

Maintenance must be performed only by qualified personnel who are trained in normal and emergency operations of the conveyor, and who are knowledgeable about all safety devices, their locations and functions.

Before restarting a conveyor:

- Remove all foreign objects from the conveyor.
- Be sure that all guards and safety devices are properly installed and working.
- Make sure that all persons are clear of the conveyor and are aware that the conveyor is about to be restarted.

Intervals indicated for performing maintenance should be considered for 8 hour per day operation. An application may subject the equipment to conditions that would necessitate more frequent maintenance. This may best be determined by performing maintenance more frequently when the conveyor is first put into operation, and then lengthening the intervals based on experience.

Table H-1 Scheduled Maintenance Summary

Interval	Components	Noise	Temperature	Bolts	Oil Level	Lubrication	Set Screws	Tensioning	Wear	Alignment	Proper Position	Physical Condition	Structural Damage	Safety Devices	Supports
Weekly	Belts and O-rings							X	X	X					
	Bearings	X	X												
	Reducer				(1)	*									
	Drive Chain and Sprockets	X													
	Belt Lacing											X			
	Safety Guards										X	X	X	X	
	General Structure											X	X	X	X
Monthly	Reducer				(2)	(2)									
	Drive Chain and Sprockets					(3)									
	Drive Pulley Hub						X								
	Drive Pulley Lagging								X			X			
500 Hours Quarterly	Belts and O-rings											X			
	Bearings			X		X									
	Reducer				(1)										
	Drive Chain and Sprockets								X	X					
	Rollers											X			
1000 Hours	Bearings											X			
	Reducer											X			
	Drive Chain and Sprockets											X			
	Drive Pulley Hub											X			
	Drive Motor	X	X	X								X			

(*) Inspect for oil leakage.

(1) Follow reducer manufacturer's instructions.

(2) Follow reducer manufacturers instructions as related to initial oil change.

(3) Check for proper oil level and operation of automatic drive chain lubricator or single and dual drive with diverter units.

Caution: Synthetic type lubricant may be used in the reducer. Pay special attention to the reducer's manufacturing specifications on lubricant type, frequency to changing, and operating oil level.

Daily Inspections

Perform walk-through inspections of the conveyor equipment each day. For continuous duty applications, conduct inspections each shift. Listen for unusual noises and carefully observe the system.

To ensure the safety of personnel, frequently check safety guards, warning signs, lights, and alarms associated with the UniSort IV, and keep them in good condition. Immediately report and correct any unusual noise, oil leak or operational problem.

Weekly Inspections

Perform the following component checks with **no power applied to the UniSort IV**:

1. Belts and “O” Rings - check for proper tension, alignment, and signs of wear.
2. Reducer - any evidence of oil leakage. Immediately check oil level if any leakage is noticed. Replace reducer if oil leakage persists.
3. Belt Lacing - tightness of the lacing. Replace the lacing if damaged.

Note: If the lacing must be replaced and the take-up adjustments permits, cut both ends of the belt squarely and install new lacing. If there is not sufficient take-up adjustment (belt too short), it is possible to splice in a minimum one foot long section of carrying belt.

4. Safety Guards/Devices - check for proper position and functioning of all safety guards and devices. Replace if any are damaged or defective.
5. General Structure - Check for any loose fasteners, damaged supports and guarding and any build up of rust or product spillage. Tighten and clean as required. Replace any damaged supports (or hangers) and guarding. Verify proper alignment.

Check the following components while the UniSort IV is operating:

CAUTION: Ensure safety of personnel while performing these checks.

1. Belts and “O” Rings - check for proper tracking of the carrying belt. Adjust as required. Observe the rotation of all “O” rings. Misalignment or excessive length due to stretching may result in the “O” ring “wobbling” or coming off. Misalignment will also cause the “O” ring to wear.
2. Bearings - Listen for any unusual noise that may indicate the need for lubrication or bearing replacement. Only the pillow block bearings can be lubricated. Use general purpose bearing grease meeting NLGI-3 specification.

CAUTION: Do not over lubricate as the grease seals may be damaged. Excessive lubrication can also result in premature bearing failure.

3. Drive Chain and Sprockets - Listen for any unusual noise that may indicate lack of lubrication, misalignment, excessive chain stretch or sprocket failure.
4. Safety Guards - Listen for any noise that may indicate a chain guard or belt guard coming in contact with a chain or belt.

Monthly Maintenance

Perform the following checks with **no power applied to the UniSort IV:**

1. Reducer - Follow reducer manufacturer's instructions for initial oil change.
2. Drive Chain and Sprockets - The UniSort IV single and dual drive units are supplied with an automatic chain oiler. Check for proper oil level in reservoir. Replace with non-detergent SAE 30 oil for above 32° F. operating temperatures. Use SAE 20 non-detergent oil for below 32° F. Ensure re-installation of any removed safety guarding.
3. Drive Pulley Hub - Check tightness of the set screws. Ensure re-installation of any removed safety guarding.
4. Drive Pulley Lagging - Check for any wear or looseness of the drive pulley lagging. Tighten any loose lagging. Replace worn out lagging.

Quarterly - 500 Hours Maintenance

Perform the following checks with **no power applied to the UniSort IV:**

1. Belts and "O" Rings - Check the physical condition of all belts and "O" rings. Clean or replace as necessary.
2. Bearings - Check pillow block bearing mounting bolts for tightness. Lubricate the pillow block bearings using NLGI-3 General Purpose Bearing Grease. Do not over lubricate.
3. Reducer - Follow reducer manufacturer's instructions on correct oil level and frequency of oil changing.
4. Drive Chain and Sprockets - Check for sign of wear and misalignment. Also see weekly and monthly checks.

CAUTION: Ensure safety of personnel while performing these checks.

5. Rollers - Check for any damaged rollers. With the UniSort IV operating, check rollers and pulleys for defective bearings.

Note: Excessive belt tension can shorten the life of the pulley and snub roller bearings.

Semi-Annual; 1000 Hours Maintenance

Perform the following component checks with **no power applied to the UniSort IV:**

Check the overall physical condition of the following:

- All bearings
- Reducer
- Drive Chain and Sprockets
- Drive Pulley Hub
- Drive Motor

Check the drive motor mounting for any loose bolts.

Note: Reinstall any safety guarding that may have been removed to perform these checks.

Belt and O-Ring Replacement for the Diverter Mechanism

The UniSort IV diverter Units are PTO driven from the Main Carrying Belt. Figure H - 1 identifies the various O-rings and Belts used to drive the rollers and pop-up Diverting Wheels. Table H-2 shows a list of belts and O-Rings that are replaceable.

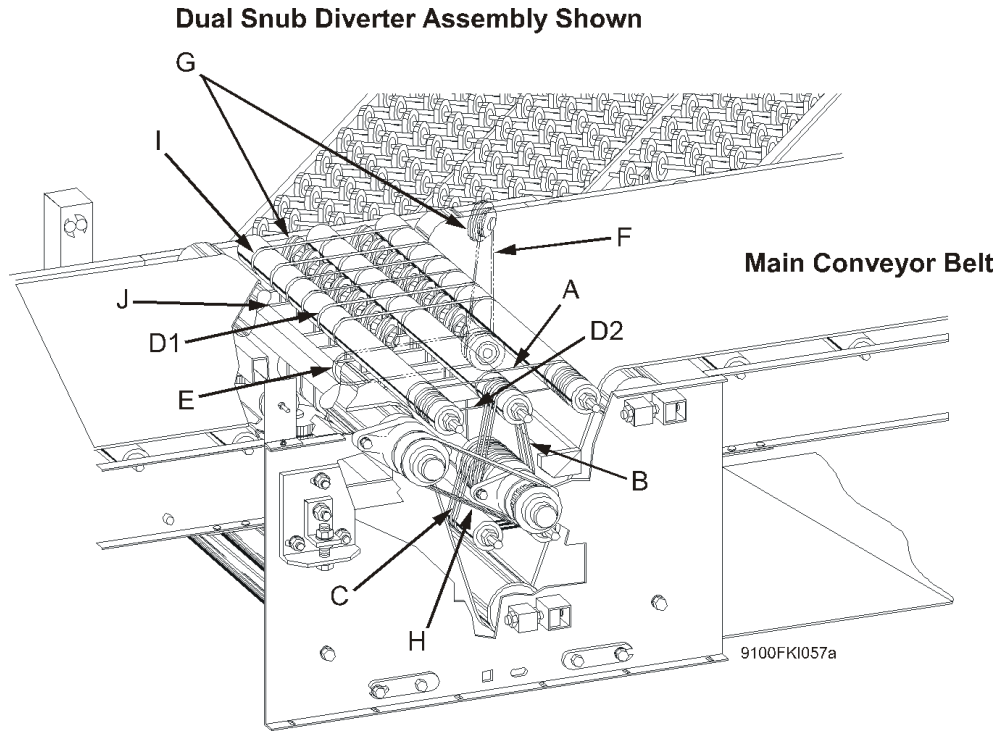

Figure H - 1 O-Rings and Belts that Drive the Rollers and Pop-up Diverting Wheels

Table H-2 Diverter Mechanism Belts

Belt	Size	Material		Use
A	3/16" x 12"	Polyurethane	7883107	Top Aluminum Roller Drive
B	1/4" x 15 3/4"	Polyurethane	7035169	6 Groove Pulley, Drive-Top Middle Roller
C	1/4" x 15 3/4"	Polyurethane	7035169	6 Grv Pulley, Drive-Bottom, Alum. Roller
D1	1/4" x 20 1/2"	Polyurethane	7035168	Drive to First Row Pop-Up Wheels (Clear)
D2	1/4" x 20 1/4"	Polyurethane	7035165	Drive to Second Row Pop-Up Wheels (Orange)
E	1/4" x 20 1/4"	Polyurethane	7035165	Drive to Grooved 2 1/2" Idler Pulley (Orange)
F	1/4" x 20 1/4"	Polyurethane	7035165	Kicker Wheel Drive, O-Ring (Orange)
G	1/4" x 6 1/8"	Polyurethane	7029474	O-Ring on Pop-Up Wheel
H	640-8M-30HTD	Neoprene w/ Nylon Lacing		PTO Drive Belt
I	1/16" x 3/4" x 22 1/2"	Polyurethane	7035167	Aluminum Roller Flat Belts
J	1/16" x 5 3/8"	Polyurethane	7035166	Top Roller Groove, O-Rings

Belt A - 3/16" x12"

The "A" belts connect from the A2 roller to the A1 and A3 rollers. The "A" belts are driven by the "A" roller which is drive by the "B" belts from shaft "BC".

"A" belts can be replaced as follows:

1. Remove the end of the rollers, from the side frame which is nearest the "A" belt to be replaced.
2. Loop the replacement belt over the rollers and slide forward until it falls into the correct groove in the rollers.
3. Re-install the ends of the "A" rollers into the side frame.

Belt B - 1/4" x 15 3/4"

The "B" belts connect from 6 groove pulley(s) on shaft "BC" to roller A2. The "B" belts are also driven by shaft "BC" and drive the center roller A2 which drives the rollers A1 and A2 with the "A" belts.

The "B" belts can be replaced as follows:

1. Remove PTO Belt "H"
2. Remove bearing "BC" (on shaft "BC" from the side frame. The 1 1/2" diameter hole in the side frame will now be exposed. Insert replacement "B" belt(s) through the hole and loop them over around shaft "BC" (see Figure H - 2).
3. Remove the end of the roller shaft A2 form the side frame, then loop the "B" belt(s) up and over the end of the A2 roller shaft.
4. Replace shaft A2 into side frame.
5. Replace bearing "BC" onto side frame.
6. Replace PTO belt H.

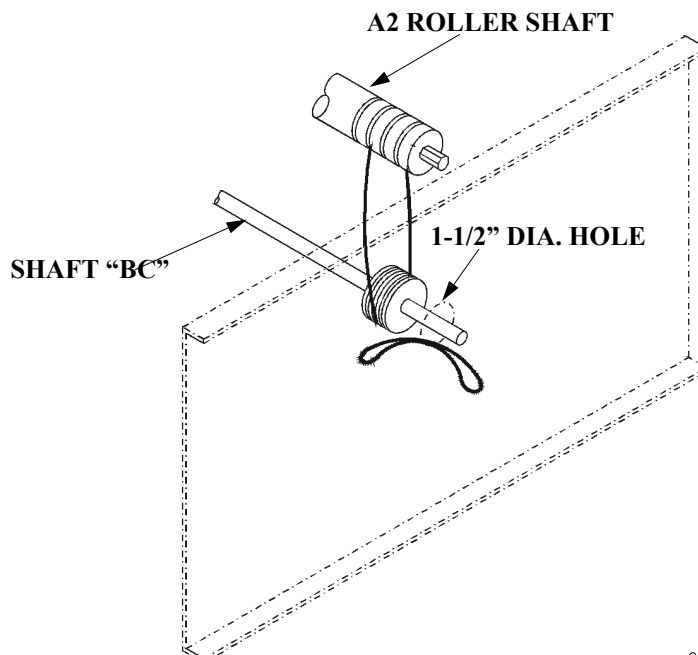

9100FKI058a

Figure H - 2

Belt C - 1/4" x 15 3/4"

The "C" belts connect from 6 groove pulley(s) on shaft "BC" to rollers C1 and C2. rollers C1 and C2 are driven by the "C" belts which are driven by shaft "BC".

Replace "C" belts as follows:

1. Remove bearing "BC" (on shaft "BC" from the side frame).
2. Because belt(s) "C" are on the inner side of belts "B", remove belts "B" from shaft "BC". Pull them out through the hole and over the end of "BC" shaft. Leave them hanging on shaft A2 (see Figure H - 3).

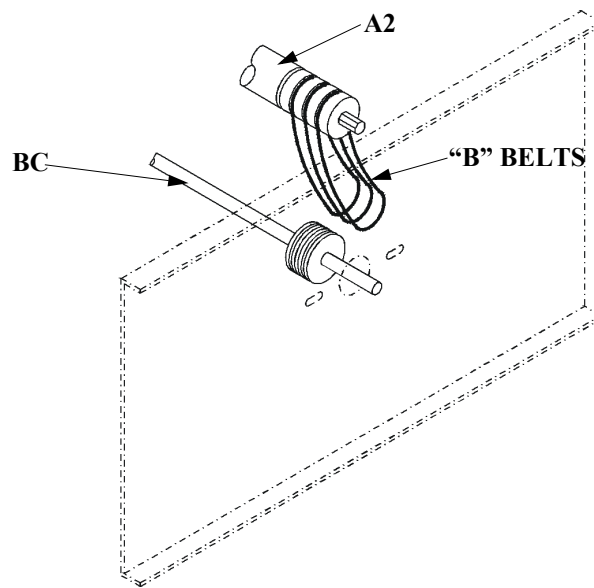

9100FKI059a

Figure H - 3

3. Insert the replacement "C" belts through the 1 1/2" diameter opening in the side frame and loop them over and around shaft "BC" into the proper grooves.
4. Replace the "B" belt(s) hanging on shaft "A" by pulling them down and looping them over and around shaft "BC", slipping them into the proper grooves.
5. Remove the two access plate screws and access plate.
6. Reach through the access opening and disconnect roller C1 from side frame and loop the replacement "C" belt(s) over and around roller C1.
7. Disconnect roller C2 from side frame and loop the replacement "C" belt(s) also over the C2 roller.
8. Replace the end of roller C2 into side frame.
9. Check that "C" belt(s) are properly seated in grooves on shaft "BC".
10. Replace access plate.
11. Replace bearing "BC" and PTO drive belt H.

Belt D1 - 1/4" x 20 1/2"

The "D" belts connect from rollers C1 and C2 to the diverter wheels' smaller diameter in the first row of diverter wheels. (row adjacent to kicker wheel).

Rollers C1 and C2 which are driven by the "C" belts drive the "D" belts which in turn drive the diverter wheels.

Replace the "D" belts as follows:

Note: Work from the side of the side frame opposite the PTO drive belt side.

1. Remove bearing "BC" from the side frame.
2. Remove the two access plate screws and access plate.

Note: Prior to replacing a "D" belt, it is best to move the existing "D" belt(s) to the next inside diverting wheel until the outside diverting wheel is the only one without a belt (see Figure H - 4).

3. Starting with the diverting wheel minus a "D" belt, move each "D" belt, by working them over the diverting wheel and sliding along the C1 and C2 rollers, to the next diverting wheel.

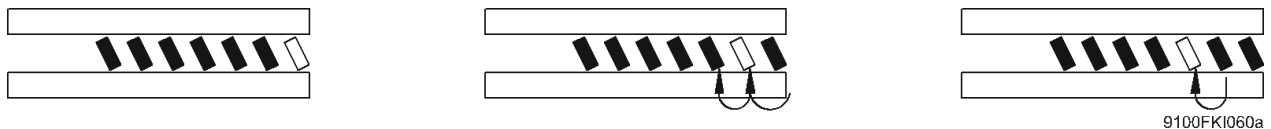

Figure H - 4

4. Working through the access opening, disconnect roller C2 or C1 (depending on which one has a broken or missing belt). Loop the replacement "D" belt over the roller.
5. Replace the end of the roller C1 and C2 into the side frame.
6. Pull the replacement "D" belt up and over the diverting wheel, looping it into the groove on the smaller diameter of the diverting wheel.
7. Replace the access plate.
8. Replace bearing "BC" and PTO drive belt H.

Belt D2 - 1/4" x 20 1/4"

Belts "D2" drives the second row of diverter wheels. A "D2" belt is replaced in the same manner as "D1" belts.

Belt E - 1/4" x 20 1/4"

The "E" belt connects from roller C2 to 2 1/2" idler pulley shaft "D" and is driven by roller C2.

Replace the "E" belt(s) as follows:

1. Remove the two access plate screws and access plate.
2. Reach through the access opening and disconnect roller C2 from the side frame.
3. Loop the replacement "E" belt over the roller.
4. Replace the end of roller C2 into the side frame.
5. Loop the replacement "E" belt over the idler shaft "D" and into the groove on the shaft.
6. Replace the access plate.

Belt F - 1/4" x 20 1/4"

The "F" belt connects from idler shaft "D" to the "kicker" diverting wheel. The "F" belt is driven by the idler shaft "D".

Replace "F" belt as follows:

1. Remove the "E" belt from the idler shaft "D": and let it hang on roller C2.
2. Loop the replacement "F" belt over the idler shaft "D" and pull it up and over into the groove on the smaller diameter of the diverter wheel.
3. Replace the "E" belt into the groove of the idler shaft "D".

Belt G - 1/4" x 6 1/8"

The "G" belt(s) are used in the grooves of the larger diameters of the diverting wheels. When the wheels are in the lowered position, the "G" belts are turning but do not contact the product as it passes over the wheels. When the wheels are in the raised position the "G" belts contact the product diverting it to the take-away conveyor.

Replace "G" belt(s) as follows:

1. Loop the replacement "G" belt over the larger diameter of the diverting wheel and into the groove making sure it is seated all the way around the wheel.

Belt H - 640-8M-30 HTD

The "H" belt is used to provide driving power from the roller shaft bearing AC to roller shaft bearing BC. Replace the belt by sipping it over the two roller shaft bearings and into the bearing grooves.

Belt I - 1/16” x 3/4” x 22 1/2”

The “I” belts connect from the A1 roller, over and under the A2 roller, to the A3 roller. All three rollers drive the “I” belts. the “I” belts help the product span the distance between the rollers when the diverter wheels are in the lowered position.

The “I” belts can be replaced as follows:

Work from the side of the side frame opposite the bearing drive belt side.

Note: Prior to replacing an “I” belt, it is best (and easier) to move the existing “I” belt(s) to the next inside roller groove until the outside roller groove is the only one without an “I” belt (see Figure H - 5).

1. Disconnect rollers A1, A2, and A3 from the side frame.
2. Slip replacement belt over roller ends and into position on the roller.
3. Reconnect rollers A1, A2, and A3 into the side frame.

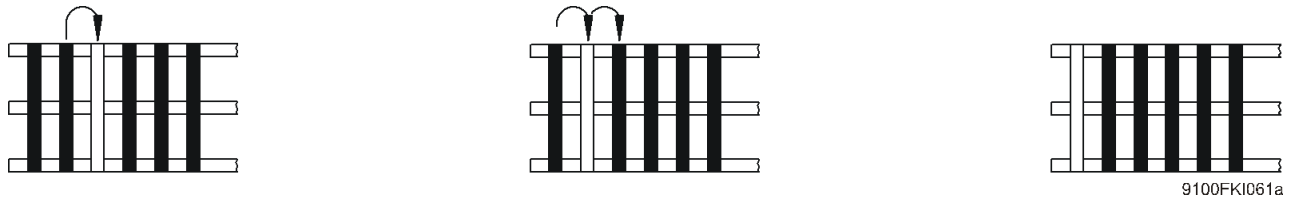

Figure H - 5

Belt J - 1/16” x 5 3/8”

The “J” belt(s) are actually O-Rings in grooves on the A1 and A2 rollers under the “I” belts.

To replace, disconnect the “A” roller from the side frame opposite the bearing drive side. Then slide the new “J” belt over the roller and position in the groove under the “I” belt.

Note: After replacing any of the diverting unit O-rings/belts, verify that none have become unseated during replacement procedures.

Adjustments

Mechanical

1. Pop-up sub-frame height.

The pivot arm adjuster is used to assure that the pop-up subframe height is correct when it is in the lowered position. It has been pre-adjusted at the factory and should need no further adjustment. If adjustment should be required; re-adjust as shown in Figure H - 6.

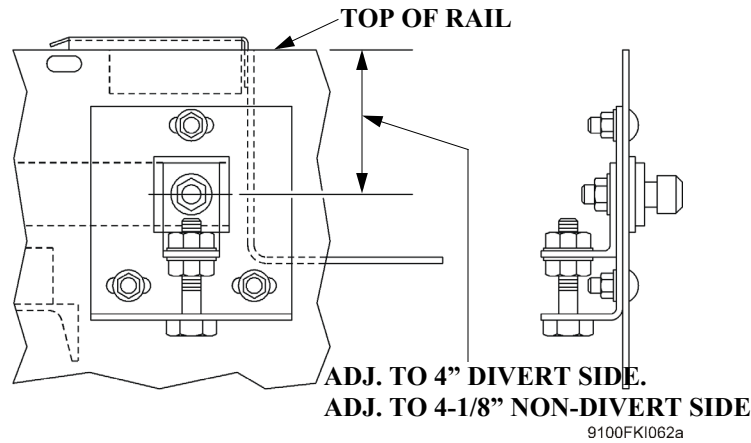

Figure H - 6

2. Motor drive sprocket chain.

Single Drive Units

Motor drive sprocket chain: Adjust for 3/8" slack at chain midpoint by moving the motor with adjustment screws (see Figure H - 7). (Also see decal inside chain guard.)

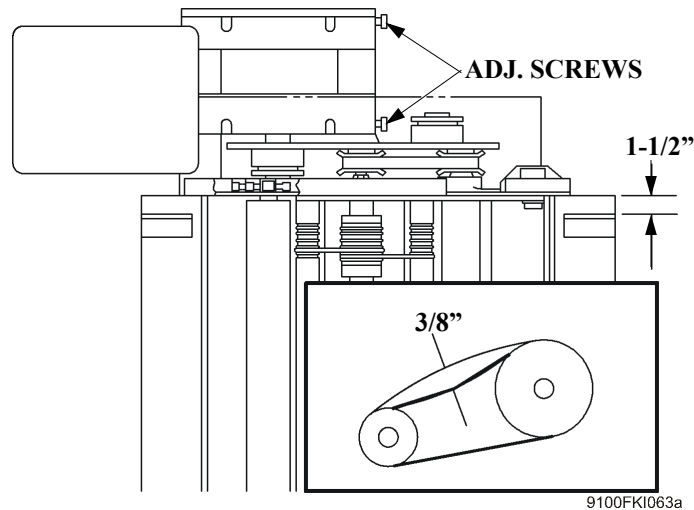
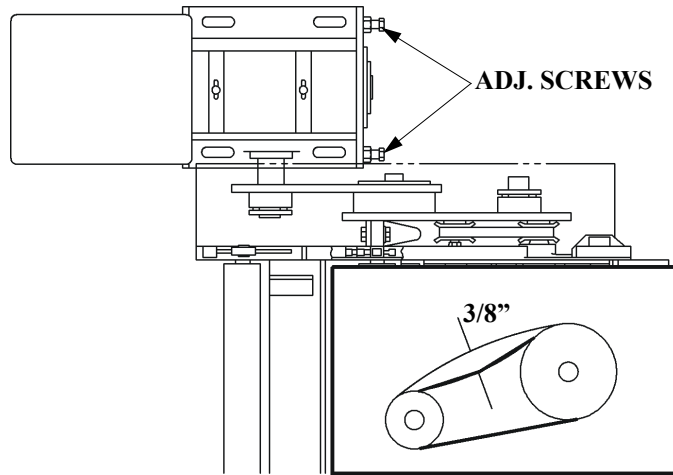

Figure H - 7

Dual Drive Units

Motor drive sprocket chain: Adjust for 3/8" total slack at chain midpoint by moving the motor with adjustment screws (see Figure H - 8).

Adjust secondary chain by raising or lower chain tensioner (see Figure H - 9). (Also see decal inside chain guard.)



9100FK1064a

Figure H - 8

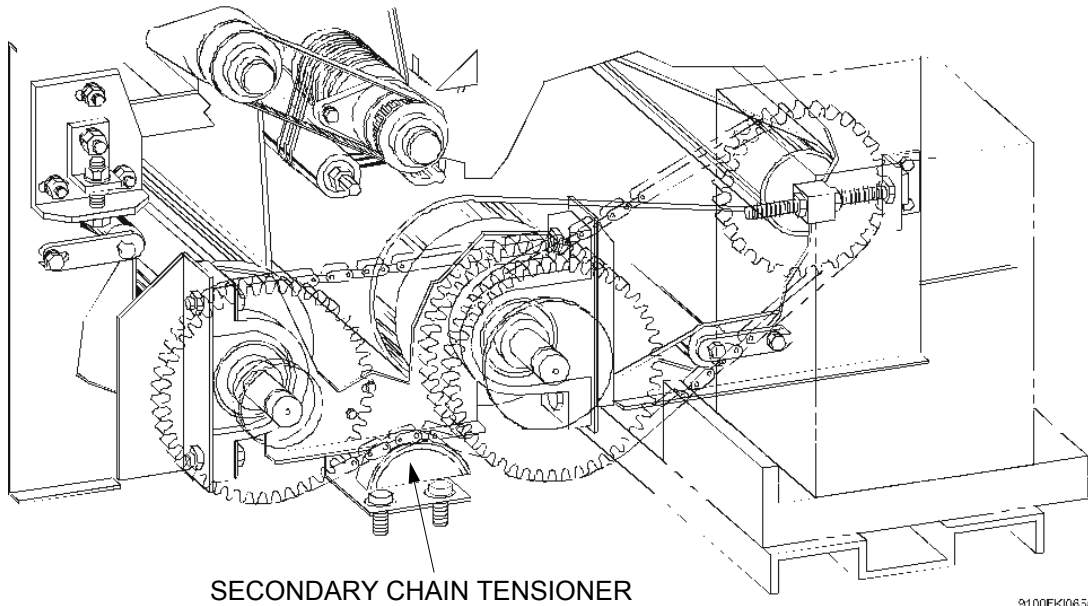

9100FK1065a

Figure H - 9

Troubleshooting Belt Problems

The following table provides guidelines in remedying belt problems. Always check belt tracking adjustments after adjusting or changing any pulleys or snub rollers.

Table H-3 Basic Belt Troubleshooting Problems and Solutions

Problem	Cause	Solution
Belt stretches excessively.	Too much positive take-up force/ belt tension.	Perform tension adjustments.
One part of belt creeps to one side.	Belt ends are not joined squarely due to the belt ends not being cut square at the joints.	Replace with new size fasteners after cutting the belt ends perfectly square using a T-square.
Entire belt creeps to one side.	Belt shifts to low side. The base structure or conveyor frame is not level or is crooked.	Stretch a string along the edge of the frame, check alignment of frame and correct. Then check the level of supporting structure.
	Alignment of pulleys, drives, tail, idlers, or snub rollers are not per- pendicular or out-of-line with center line of conveyor.	Use a T-square against the edge of the conveyor and pulleys or idlers to recheck and square the pulleys. Re-check belt tracking adjust- ments.
Belt creeps to one side in the infeed area.	Infeed end pulley is out-of-line.	First, adjust snub roller. Second, realign infeed end pulley by advancing (belt travel direction) the end of the pulley or idler to which the belt has shifted.
Belt creeps to one side in the dis- charge end area.	Discharge end pulley is out-of-line (not perpendicular with center line of the conveyor).	First, adjust snub roller. Second, realign infeed end pulley by advancing (return belt travel direc- tion) the end of the pulley or idler to which the belt has shifted.
Belt wanders irregularly	The conveyor is over-belted. This results in the belt being too stiff to properly operate over the pulley diameters.	Change to the proper belt or use pulleys with larger diameters.
	Off center or improper loading.	Correct loading procedure.
Belt fasteners pulling out.	Fasteners are incorrect size.	Re-lace belt with proper size fasteners.
	Too much tension on belt.	Relieve tension until belt will run without slipping on the drive pulley.
	Pulley diameters too small for the thickness of belt used.	Replace with larger diameter pulleys; or thinner belt if practical.

Problem	Cause	Solution
Edge wear is excessive.	Belts edges fold up on conveyor guards, frame, kicker wheel	Remove the rough areas on conveyor guards or frame. Check belt tracking.
	Belt shifts to opposite side and rubs excessively due to side loading.	Loading in direction of belt travel will improve this condition.

SECTION I: PARTS IDENTIFICATION

General Information

The purpose of this section is to provide a list of common spare parts for a preventive maintenance program and also to minimize the chances for extended DOWNTIME.

The following pages illustrate the location of these recommended spare parts as they apply to each particular unit. Keep in mind that these illustrations apply to the STANDARD product line and to project specific parts. These items will show up on the Bill of Material as a “coded” item. For example: there will also be items on the Bill of Material such as gearmotors, sprockets, chain, etc., that will also show up on the price sheets.

Diverter Unit

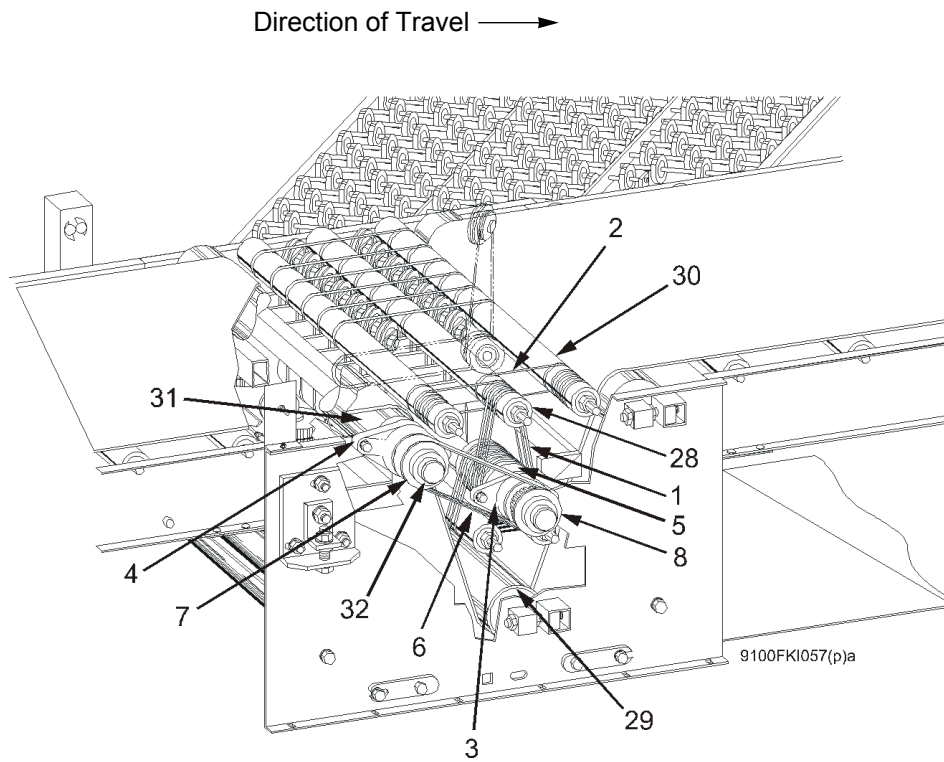
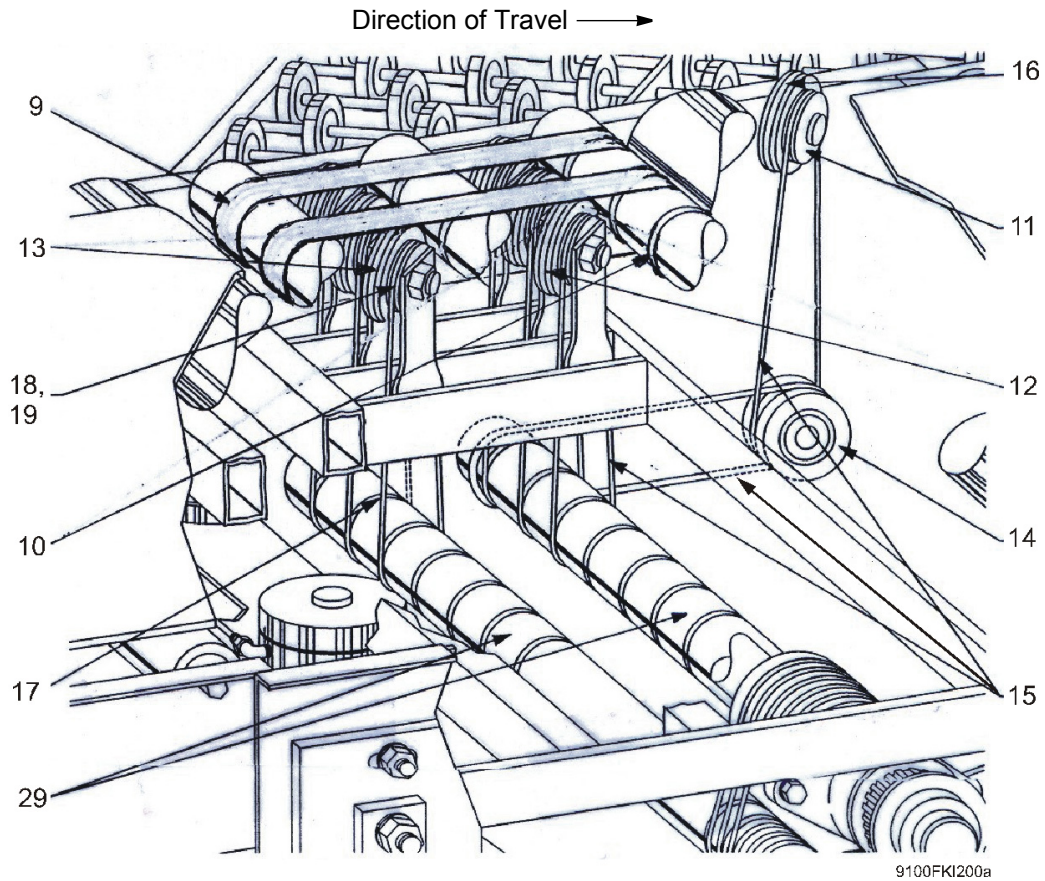

Figure I - 1 Diverter Unit, Outer Parts, (Dual Snub Diverter Shown)



9100FKI200a

Figure I - 2 Diverter Unit, Inner Parts, (Dual Snub Diverter Shown)

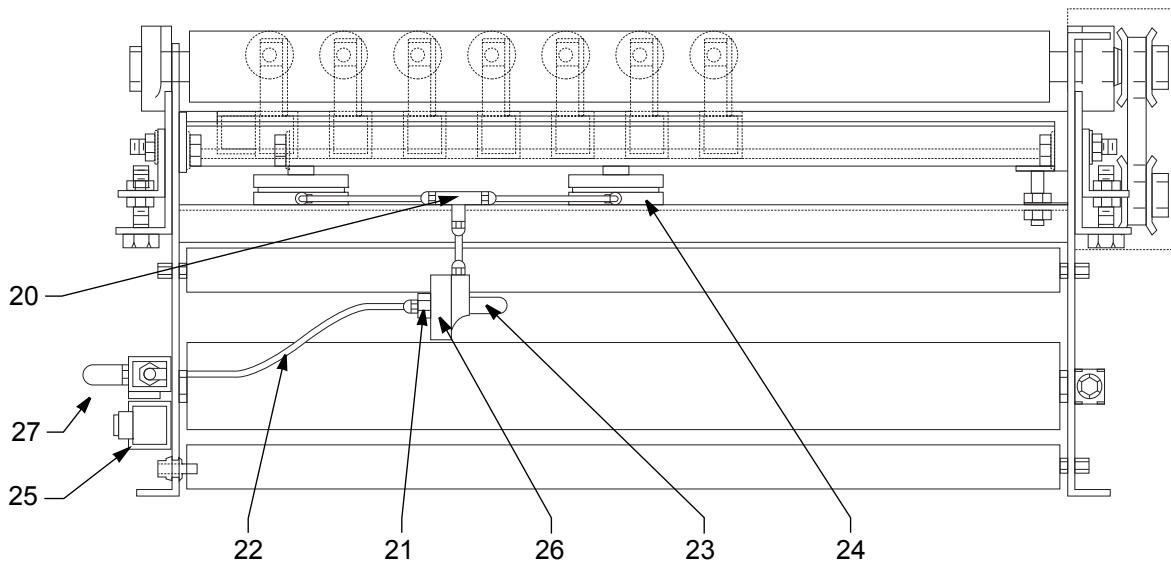

Figure I - 3 Diverter Unit, Pneumatic Components, (Dual Snub Diverter Shown)

Diverter Spare Parts, Non-width Related

Key #	Part Description	Part Number
1	Polyurethane Belt 1/4" x 15-3/4"	7035169
2	Polyurethane Belt 3/16" x 12"	7883107
3	Flange Bearing, 2-Bolt 1" Bore	7010490
4	Flange Bearing, 2 Bolt, 1-3/16" Bore	7060572
5	MSS Drum Pulley	685000
6	HTD Timing Belt 640-8M-30	759510
7	Timing Belt Sprocket, 1 3/16" Bore	PS549507
8	Timing Belt Sprocket, 1" Bore	PS549508
9	Urethane Belt 22 1/2" x 3/4" x 1/16"	7035167
10	Polyurethane O-Ring 1/16" x 5-3/8"	7035166
11	MSS Diverter Wheel Assembly, 01 A=1.125", (Kicker, Row 3)	000905
12	MSS Diverter Wheel Assembly, 02 A=1.271", (Large Groove, Row 2)	000906
13	MSS Diverter Wheel Assembly, 03 A=1.462", (Small Groove, Row 1)	000907
14	MSS Diverter Id Hub Assembly 2-1/2"x2"LG	000919
15	Polyurethane O-Ring 1/4" x 20-1/4", 83A, (Orange, Row 2 and Row 3)	7035165
16	Polyurethane O-Ring 1/4" x 6-1/8"	7029474
17	Polyurethane O-Ring 1/4" x 20-1/2" (Clear, Row 1)	7035168
18	Unisort Washer, 1.115 od x 5/8"	000513
19	Diverter Wheel Axle, Plated	000904
20	Tee, Union, 3/8" Tube, Push To	7536413
21	Straight Connector 3/8T x 1/4MPT	7060508
22	3/8" od Flexible Hipress Tubing	7060509
23	Silencer, 1/4MPT Allied Witan	7060583
24	Actuator, Pancake Cylinder, 3"BR X .313ST MSS	7023944
25	Valve, 3-way, Alkon PMC1SS115/60	7060505
26	Quick Exhaust Valve, 1/4" Pipe	7035554
27	Silencer 1/8MPT	271781
27a	Bearing Assy. ASQ6205 Wolverine (251) Single & Dual Drive (Not Shown)	7106205
27b	Connecting Links RC-80 (Dual Drive) (Not Shown)	7311080

Diverter Spare Parts Width Related (Conveyor Width)

Key #	Part Description	Part Number by Conveyor Width			
		18"	24"	30"	36"
28	MSS Grooved Roller, ABEC	509957	509958	509959	509960
29	MSS Drive Roller Assembly Bottom ABEC	509949	509950	509951	509952
30	MSS Grooved Drive Roller, ABEC	509953	509954	509955	509956
31	MSS PTO Pulley, 3" CFX 1 3/16	685011	685012	685013	685014
32	MSS Drum Shaft, 1" dia	695001	695002	695003	695004
32a*	Roller (Not Shown)				
	RLR G196 A1 P 01 __. __ NC	7504895	7504834	7504843	7504852

(*) See Roller Description Explanation on page I-10

Diverter Belt Rollers

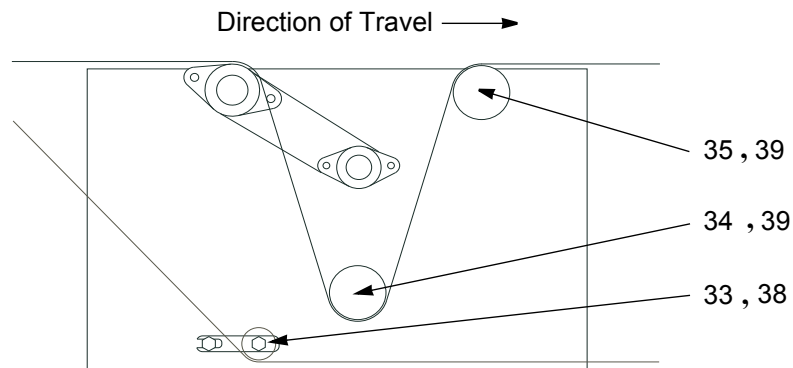

Figure I - 4 End Diverter (Front View)

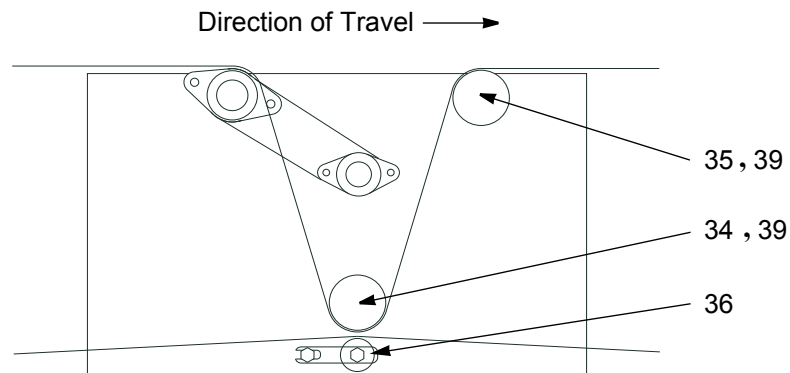

Figure I - 5 Intermediate Diverter (Front View)

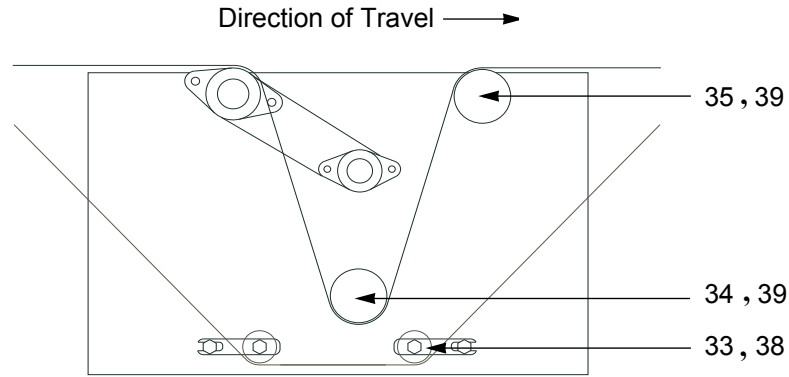

Figure I - 6 Dual Snub Roller Diverter (Front View)

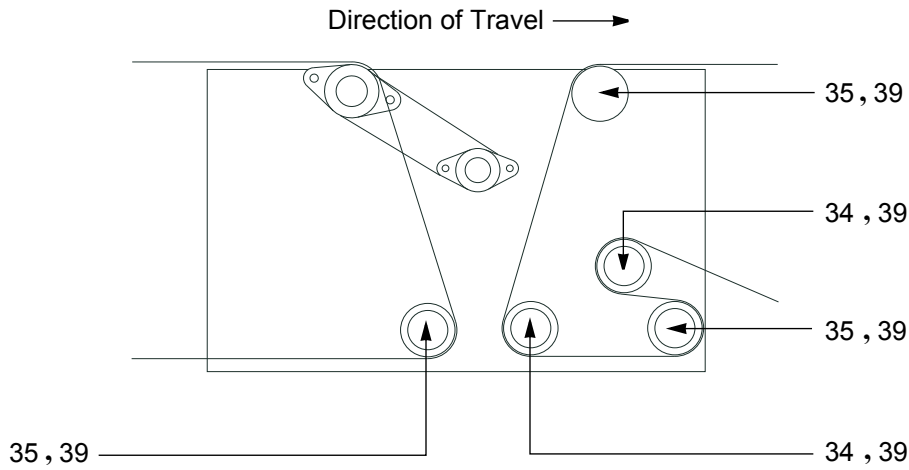

Figure I - 7 Interface Diverter with Take-Up & Idler Rollers (Front View)

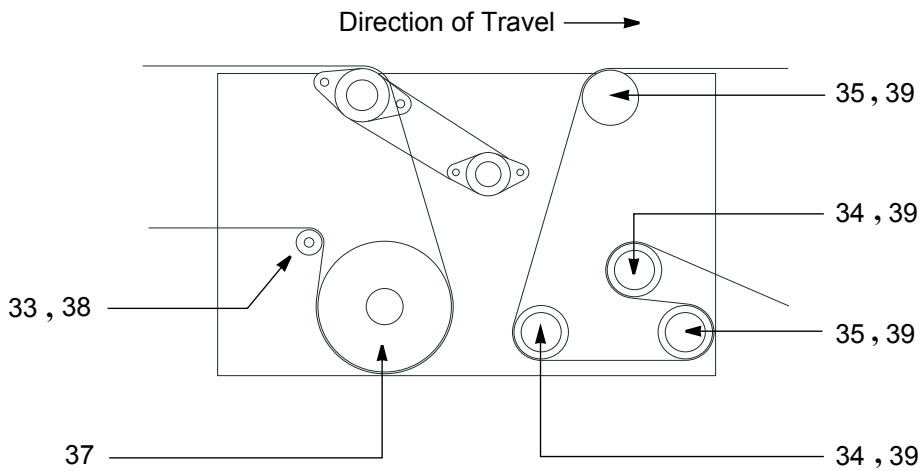

Figure I - 8 Single Drive Diverter (Front View)

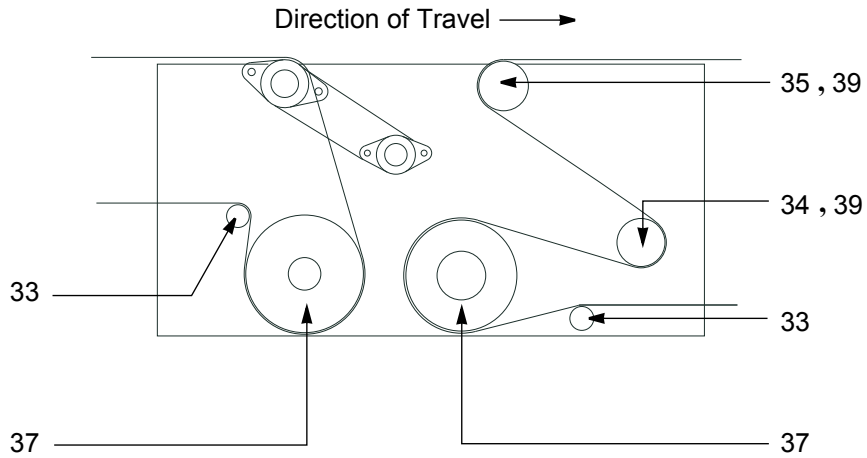

Figure I - 9 Dual Drive Diverter (Front View)

Diverter Belt Roller Parts, Width Related

Table I - 1 – Diverter Spare Parts, Non-width Related

Key #	Part Description	Part Number by Conveyor Width			
		18"	24"	30"	36"
33	Roller G251AB BX-	501025	501026	501027	501028
34	Idler Roller 3-1/2FF	501223	501224	501225	501226
35	Idler Roller 3 1/2CF	501227	501228	501229	501230
36*	Roller (Not Shown)				
	RLR G196 A1 P 01 __. __ NC	7504895	7504834	7504843	7504852
37	Drive Pulley & Shaft, CF	682601	682602	682603	682604
38	Axle, 11/16, Tapped Ends	501140	501141	501142	501143
38a	Idler Roller 3-1/2FF	501223	501224	501225	501226

(*) See Roller Description Explanation on page I-10.

Diverter Belt Roller Parts, Non-width Related

Table I.1 – Diverter Belt Roller Parts, Non-width Related

Key #	Part Description	Part Number
39	Bearing, 3 1/2" Takeup/Idler Roller, 1 1/8" SQ	7350360
39a	Flat Adj Ret Roller 1 x 1/8 x 4 3/8 (not shown)	7030020

Parts Not Illustrated

The following parts do not appear in the illustrations.

Key #	Part Description	Part Number
	Bumper Rubber FB-4444	7885294
	Single Gang Remote Bracket	000502
	Even-flo Applicator Brush	000503
	Oiler Reservoir LDI	000890

Nondivert Sorter Modules

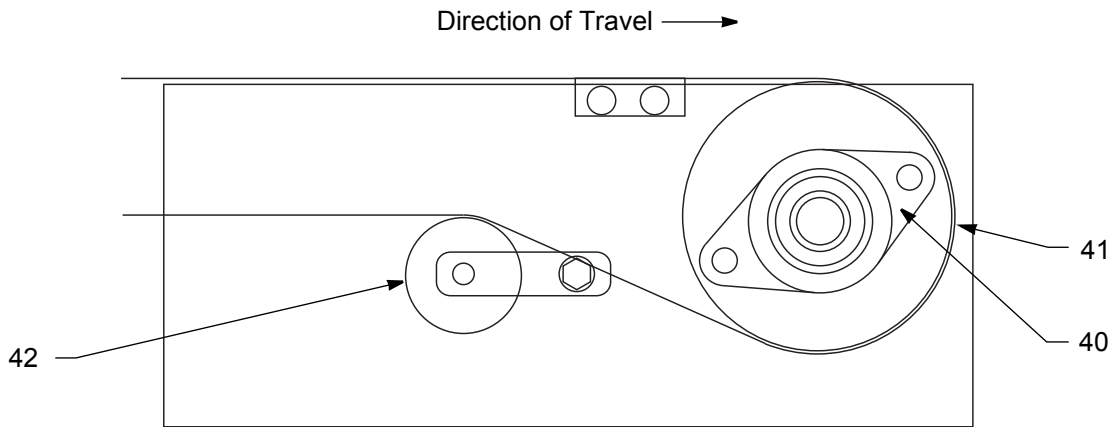

Figure I - 2 End Drive (No Drive Unit)

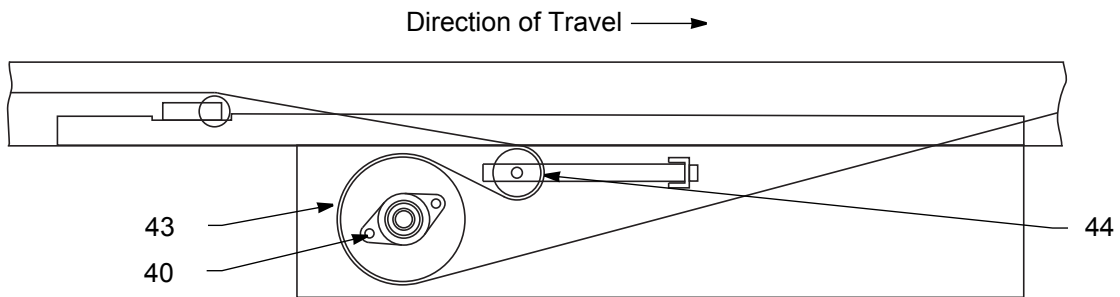

Figure I - 3 Center Drive (No Drive Unit)

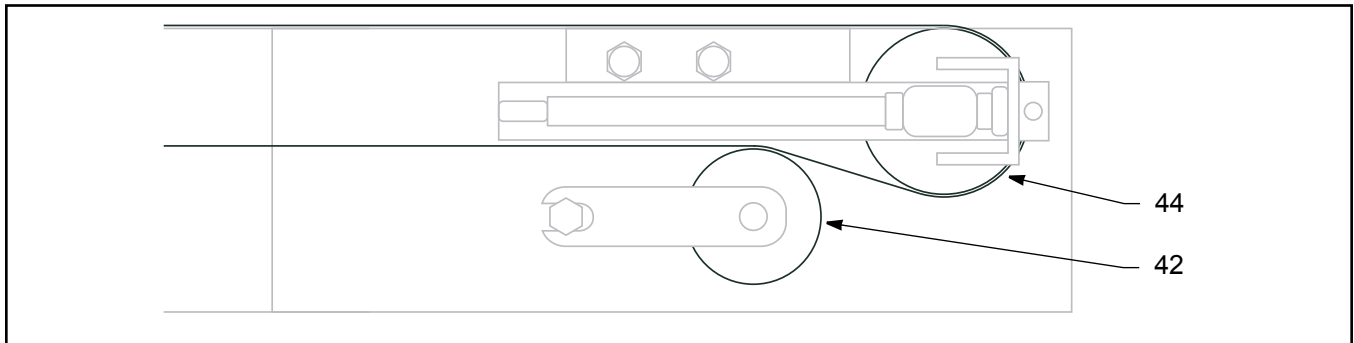

Figure I - 4 End Idler

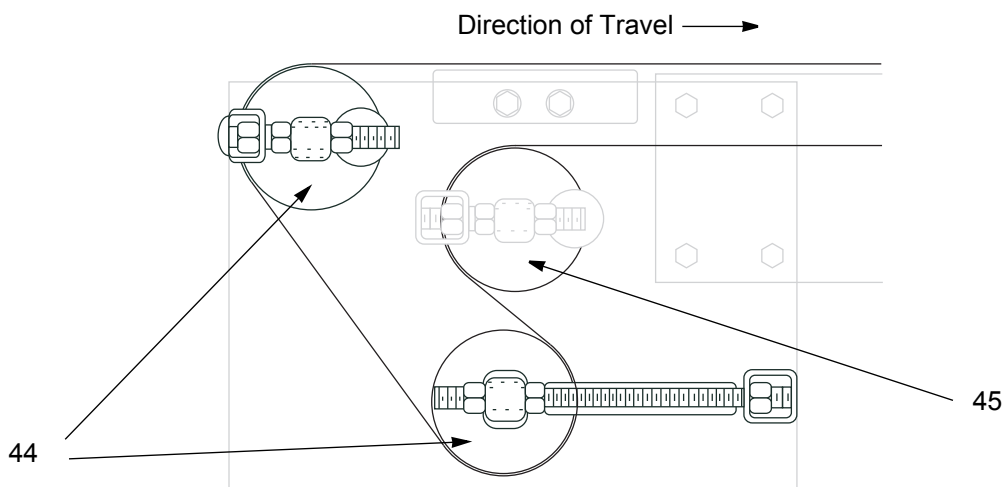

Figure I - 5 End Take-Up

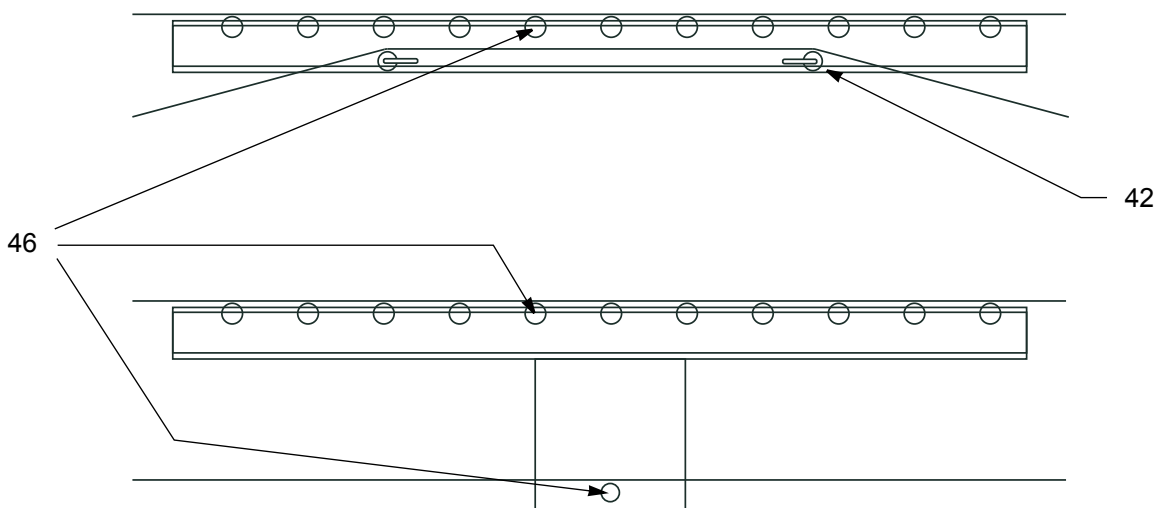

Figure I - 6 Intermediate Sections

Table I - 7 – Nondivert Module Spare Parts (Non-width Related)

Key #	Part Description	ParNumber
40	Flange Bearing 1-7/16" D. Bore	7001757

Table I - 8 – Nondivert Module Spare Parts (Width Related)

Key #	Part Description	Part Number by Belt Width			
		15"	21"	27"	33"
41	Drive Pulley	680519	680520	680521	680524
42	Snub Roller	502474	502475	502476	502466
43	Drive Pulley	681360	680522	680523	680524
44	Take-upRoller3-1/2"CF,1-1/8"SQ	501216	501217	501218	501219
45	Snub Roller 3-1/2" CF, 1-1/8" SQ	501321	501322	501323	501324
46*	Roller				
	RLR G196 A1 P 01 __. __ NC	7504822	7504830	7504838	7504849
	RLR G196 GH P01 __. __ NC	7496310	7496413	7496510	7496588

(*) See Roller Description Explanation

(Example) RLR G196 GH P 01 15.00 NC

NC = No Cover
 15.00 = Conveyor Width "W"
 01 = Spring-Loaded Axle; Fixed Roller w/o Grooves
 P = Plain Steel Axle
 A1 = (Bearing Type) ABEC Precision Bearing
 196 = (Roller Tube) 1.90" dia x 16 gage (.065" wall)
 G = (Roller Tube Material/Finish) Galvanized Steel
 RLR = Roller

Drive Components

The drive for a Unisort IV sorter may be located at a diverter unit or at another location, such as an end drive or a center drive.

Drives Located at a Diverter Unit

The configuration of a drive located at a diverter unit may be either single drive or dual drive. Drive components vary according to drive configuration, motor horsepower and sorter speed. Drive components are presented with a figure and table for each combination of drive configuration and motor horsepower, in the following order:

Single Drive

- 1 Horsepower
- 1.5 Horsepower
- 2 Horsepower
- 3 Horsepower
- 5 Horsepower
- 7.5 Horsepower

Dual Drive

- 2 Horsepower
- 3 Horsepower
- 5 Horsepower
- 7.5 Horsepower
- 10 Horsepower
- 15 Horsepower

Drives at Other Locations

Spare parts for drives at locations other than at the diverter unit are documented in the product manual *CS8100, Powered Belt*, in Section I, "Spare Parts."

Single Drive, 1 Horsepower

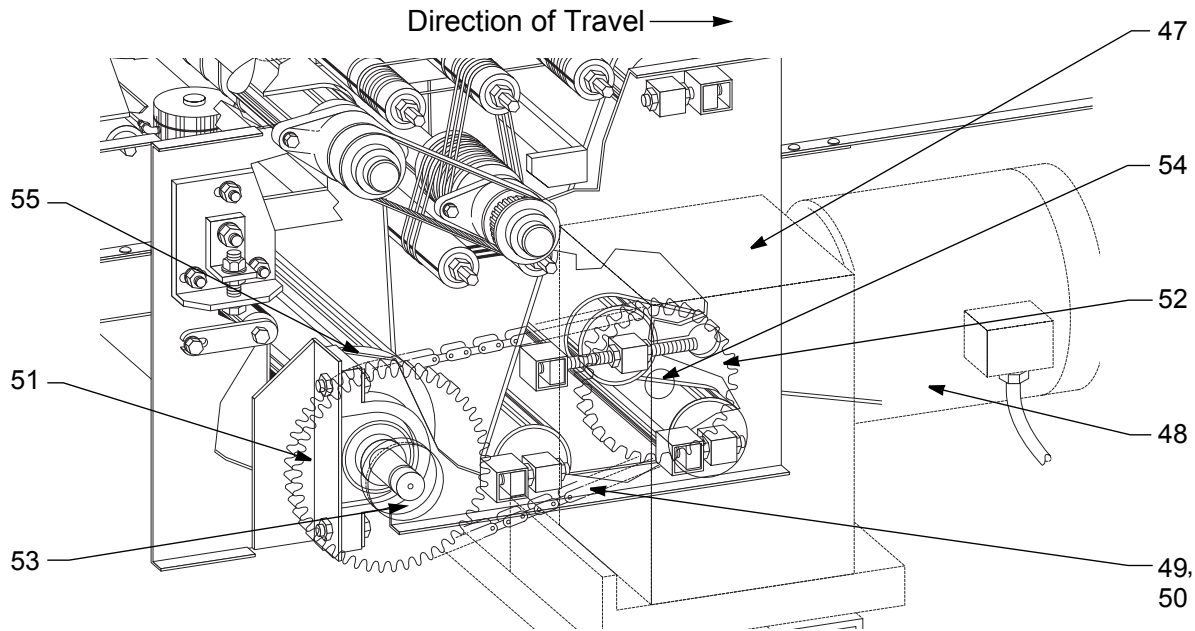

Figure I - 9 Drive Assembly, Single Drive Diverter

Single Drive Diverter (RH & LH), 1 Horsepower

Key #	Part Description	Speed (FPM)				
		150	180	220	250	300
47	Gear Reducer (Right Hand)	811246	811204	811204	811202	811202
	Gear Reducer (Left Hand)	811245	811203	811203	811201	811201
48	Motor	330707	330707	330707	330707	330707
49	Chain	200987	200987	200987	200987	200987
50	Chain Coupler	7311060	7311060	7311060	7311060	7311060
51	Sprocket (Driven)	745644 (24tooth)	745644 (24tooth)	745644 (24tooth)	745644 (24tooth)	745644 (24tooth)
52	Sprocket (Driver)	745639 (19tooth)	745637 (17tooth)	745641 (21tooth)	745636 (16tooth)	745639 (19tooth)
53	Hub (for Driven Sprocket)	230782& 7758291	230782& 7758291	230782& 7758291	230782& 7758291	230782& 7758291
54	Hub (for Driver Sprocket)	230946	230946	230976	230946	230946
55	Pillow Block	400330	400330	400330	400330	400330

Single Drive, 1.5 Horsepower

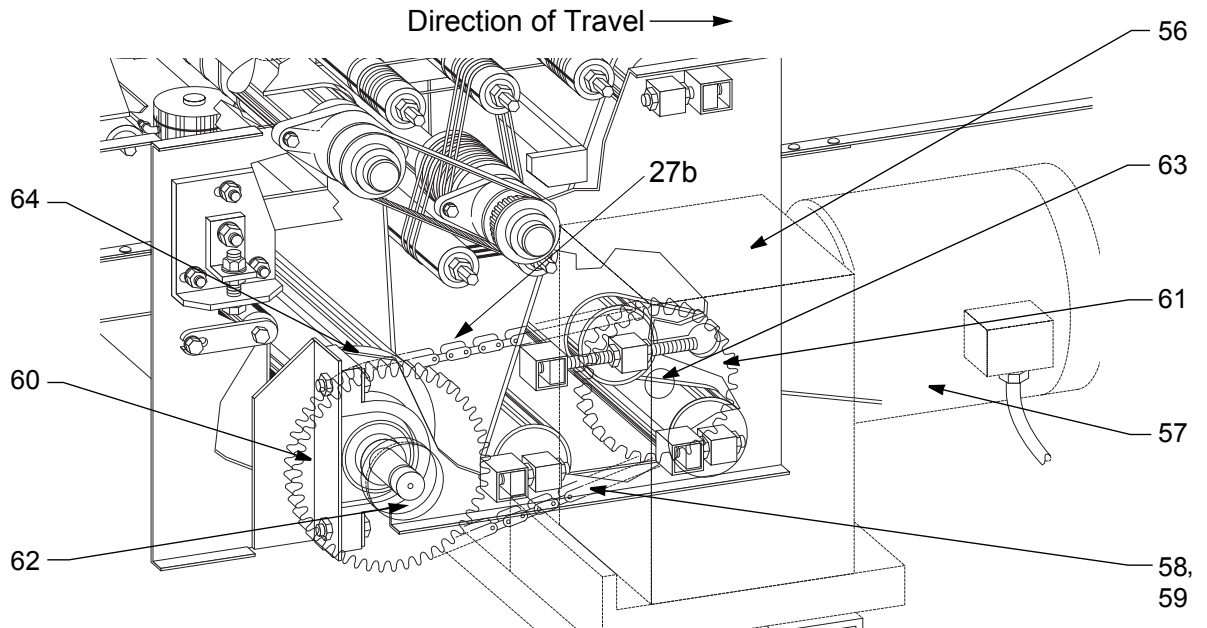

Figure I - 10 Drive Assembly, Single Drive Diverter

Table I - 11 – Single Drive Diverter (RH & LH), 1.5 Horsepower

Key #	Part Description	Speed (FPM)				
		150	180	220	250	300
56	Gear Reducer (Right Hand)	811208	811206	811206	811202	811202
	Gear Reducer (Left Hand)	811207	811205	811205	811201	811201
57	Motor	330709	330709	330709	330709	330709
58	Chain	200987	200987	200987	200987	200987
59	Chain Coupler	7311060	7311060	7311060	7311060	7311060
60	Sprocket (Driven)	745644 (24tooth)	745644 (24tooth)	745644 (24tooth)	745644 (24tooth)	745644 (24tooth)
61	Sprocket (Driver)	745639 (19tooth)	745637 (17tooth)	745641 (21tooth)	745636 (16tooth)	745639 (19tooth)
62	Hub (for Driven Sprocket)	230782& 7758291	230782& 7758291	230782& 7758291	230782& 7758291	230782& 7758291
63	Hub (for Driver Sprocket)	230752	230752	230784	230946	230946
64	Pillow Block	400330	400330	400330	400330	400330

Single Drive, 2 Horsepower

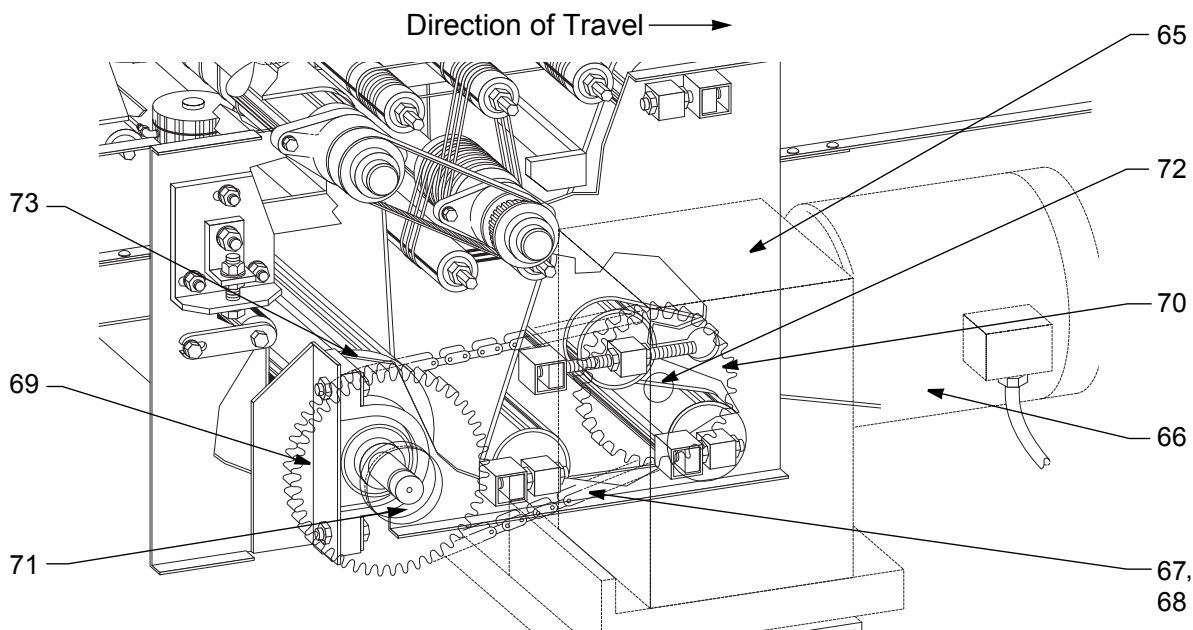

Figure I - 12 – Drive Assembly, Single Drive Diverter

Table I - 13 – Single Drive Diverter (RH & LH), 2 Horsepower

Key #	Part Description	Speed (FPM)				
		150	180	220	250	300
65	Gear Reducer (Right Hand)	811214	811248	811248	811210	811210
	Gear Reducer (Left Hand)	811213	811247	811247	811209	811209
66	Motor	330711	330711	330711	330711	330711
67	Chain	200987	200987	200987	200987	200987
68	Chain Coupler	7311060	7311060	7311060	7311060	7311060
69	Sprocket (Driven)	745644 (24tooth)	745644 (24tooth)	745644 (24tooth)	745644 (24tooth)	745644 (24tooth)
70	Sprocket (Driver)	745639 (19tooth)	745637 (17tooth)	745641 (2tooth)	745636 (16tooth)	745639 (19tooth)
71	Hub (for Driven Sprocket)	230782& 7758291	230782& 7758291	230782& 7758291	230782& 7758291	230782& 7758291
72	Hub (for Driver Sprocket)	2155220	2155220	230780	230752	230752
73	Pillow Block	400330	400330	400330	400330	400330

Single Drive, 3 Horsepower

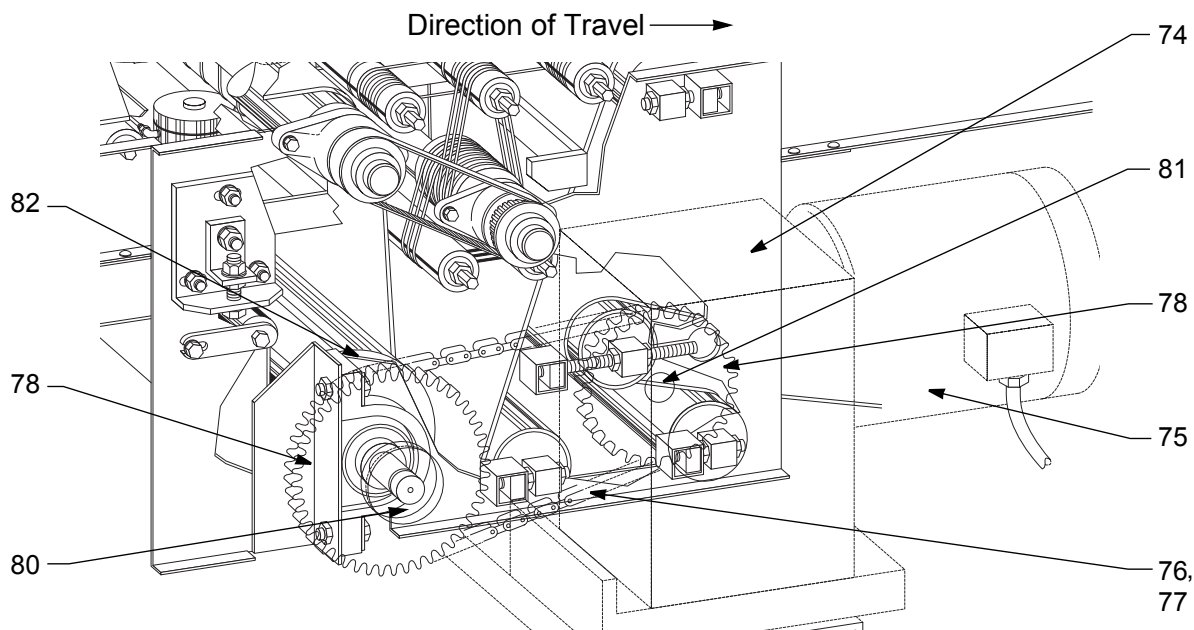

Figure I - 14 – Drive Assembly, Single Drive Diverter

Table I - 15 – Single Drive Diverter (RH & LH), 3 Horsepower

Key #	Part Description	Speed (FPM)				
		150	180	220	250	300
74	Gear Reducer (Right Hand)	811222	811218	811218	811250	811250
	Gear Reducer (Left Hand)	811221	811217	811217	811249	811249
75	Motor	330713	330713	330713	330713	330713
76	Chain	200987	200987	200987	200987	200987
77	Chain Coupler	7311060	7311060	7311060	7311060	7311060
78	Sprocket (Driven)	745644 (24tooth)	745644 (24tooth)	745644 (24tooth)	745644 (24tooth)	745644 (24tooth)
79	Sprocket (Driver)	745639 (19tooth)	745637 (17tooth)	745641 (2tooth)	745636 (16tooth)	745639 (19tooth)
80	Hub (for Driven Sprocket)	230782& 7758291	230782& 7758291	230782& 7758291	230782& 7758291	230782& 7758291
81	Hub (for Driver Sprocket)	230953	2155220	230780	230752	230752
82	Pillow Block	400330	400330	400330	400330	400330

Single Drive, 5 Horsepower

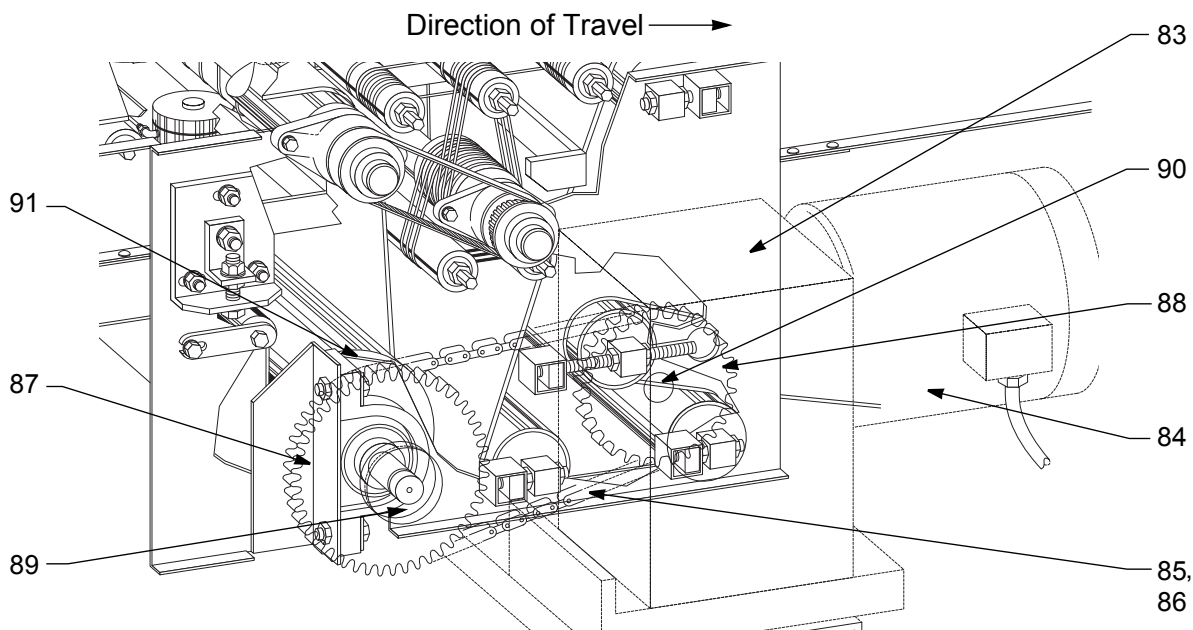

Figure I - 16 – Drive Assembly, Single Drive Diverter

Table I - 17 – Single Drive Diverter (RH & LH), 5 Horsepower

Key #	Part Description	Speed (FPM)				
		150	180	220	250	300
83	Gear Reducer (Right Hand)	811230	811228	811228	811224	811224
	Gear Reducer (Left Hand)	811229	811227	811227	811223	811223
84	Motor	330715	330715	330715	330715	330715 (330721 RH)
85	Chain	200987	200987	200987	200987	200987
86	Chain Coupler	7311060	7311060	7311060	7311060	7311060
87	Sprocket (Driven)	745644 (24tooth)	745644 (24tooth)	745644 (24tooth)	745644 (24tooth)	745644 (24tooth)
88	Sprocket (Driver)	745639 (19tooth)	745637 (17tooth)	745641 (21tooth)	745636 (16tooth)	745639 (19tooth)
89	Hub (for Driven Sprocket)	230782& 7758291	230782& 7758291	230782& 7758291	230782& 7758291	230782& 7758291
90	Hub (for Driver Sprocket)	230951	230951	230987	230953	230953
91	Pillow Block	400330	400330	400330	400330	400330

Single Drive, 7.5 Horsepower

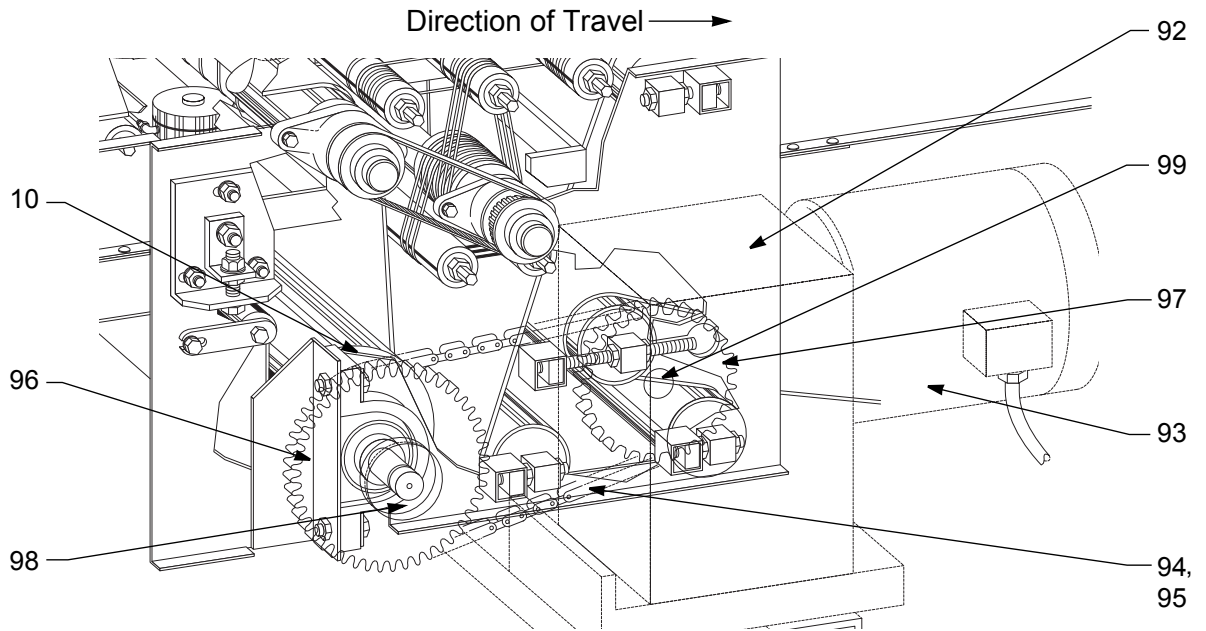

Figure I - 18 – Drive Assembly, Single Drive Diverter

Table I - 19 – Single Drive Diverter (RH & LH), 7.5 Horsepower

Key #	Part Description	Speed (FPM)				
		150	180	220	250	300
92	Gear Reducer (Right Hand)	–	–	811234	811232	811232
	Gear Reducer (Left Hand)	–	–	811233	811231	811231
93	Motor	–	–	330721	330721	330721
94	Chain	–	–	200987	200987	200987
95	Chain Coupler	–	–	7311060	7311060	7311060
96	Sprocket (Driven)	–	–	745644 (24tooth)	745644 (24tooth)	745644 (24tooth)
97	Sprocket (Driver)	–	–	745641 (2tooth)	745636 (16tooth)	745639 (19tooth)
98	Hub (for Driven Sprocket)	–	–	230782& 7758291	230782& 7758291	230782& 7758291
99	Hub (for Driver Sprocket)	–	–	230786	230951	230951
100	Pillow Block	–	–	400330	400330	400330

Dual Drive, 2 Horsepower

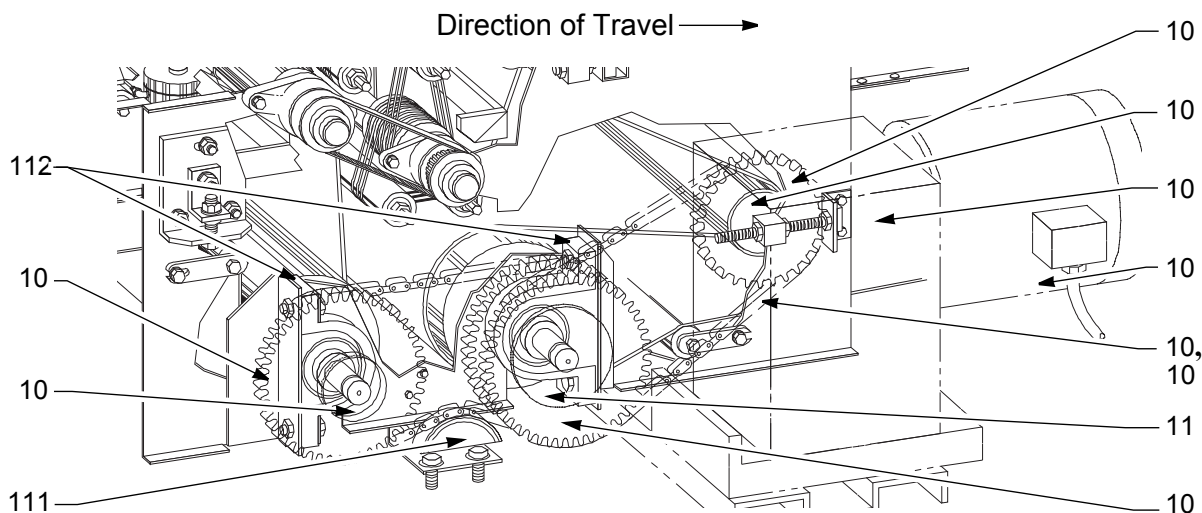

Figure I - 20 – Drive Assembly, Dual Drive Diverter

Table I - 21 – Dual Drive Diverter (RH & LH), 2 Horsepower

Key #	Part Description	Speed (FPM)				
		150	180	220	250	300
101	Gear Reducer (Right Hand)	811214	811248	811214	811210	811210
	Gear Reducer (Left Hand)	811213	811247	811247	811209	811209
102	Motor	330711	330711	330711	330711	330711
103	Chain	200987	200987	200987	200987	200987
104	Chain Coupler	7311060	7311060	7311060	7311060	7311060
105	Sprocket (PTO)	745644 (24tooth)	745644 (24tooth)	745644 (24tooth)	745644 (24tooth)	745644 (24tooth)
106	Sprocket (Driver)	745639 (19tooth)	745637 (17tooth)	745641 (21tooth)	745636 (16tooth)	745639 (19tooth)
107	Sprocket (Double)	749552 (24tooth)	749552 (24tooth)	749552 (24tooth)	749552 (24tooth)	749552 (24tooth)
108	Hub (for PTO Sprocket)	230782& 7758291	230782& 7758291	230782& 7758291	230782& 7758291	230782& 7758291
109	Hub (for Driver Sprocket)	2155220	230752	230784	230752	230752
110	Hub (for Double Sprocket)	230793	230793	230793	230793	230793
111	Chain Tensioner	201121	201121	201121	201121	201121
112	SMC Pillow Block	400335	400335	400335	400335	400335

Dual Drive, 3 Horsepower

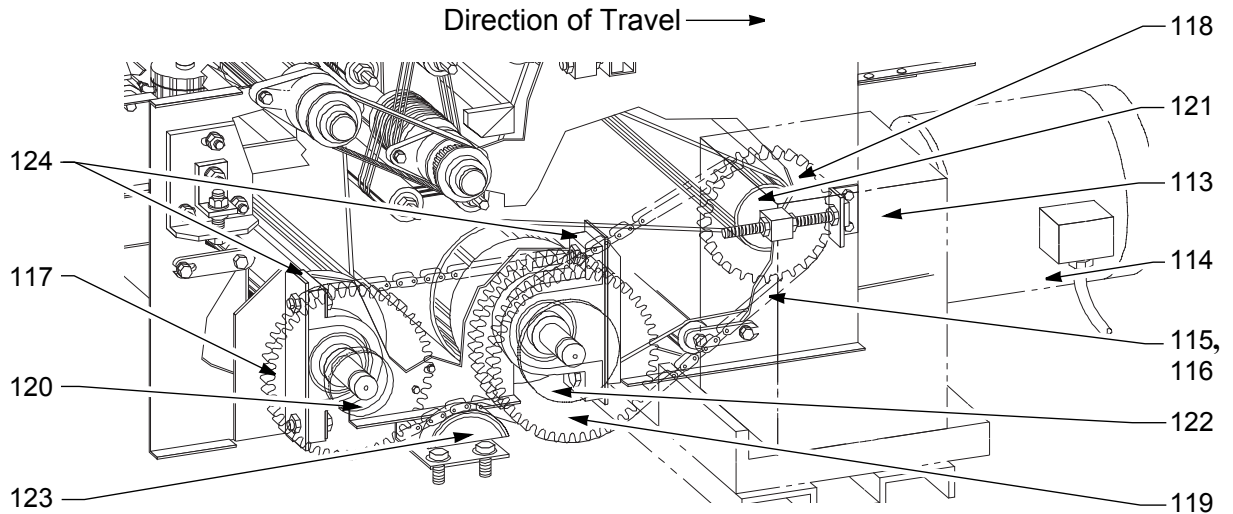

Figure I - 22 – Drive Assembly, Dual Drive Diverter

Table I - 23 – Dual Drive Diverter (RH & LH), 3 Horsepower

Key #	Part Description	Speed (FPM)				
		150	180	220	250	300
113	Gear Reducer (Right Hand)	811222	811218	811218	811247	811250
	Gear Reducer (Left Hand)	811221	811217	811217	811249	811249
114	Motor	330713	330713	330713	330713	330713
115	Chain	200987	200987	200987	200987	200987
116	Chain Coupler	7311060	7311060	7311060	7311060	7311060
117	Sprocket (PTO)	745644 (24tooth)	745644 (24tooth)	745644 (24tooth)	745644 (24tooth)	745644 (24tooth)
118	Sprocket (Driver)	745639 (19tooth)	745637 (17tooth)	745641 (21tooth)	745636 (16tooth)	745639 (19tooth)
119	Sprocket (Double)	749552 (24tooth)	749552 (24tooth)	749552 (24tooth)	749552 (24tooth)	749552 (24tooth)
120	Hub (for PTO Sprocket)	230782& 7758291	230782& 7758291	230782& 7758291	230782& 7758291	230782& 7758291
121	Hub (for Driver Sprocket)	230953	2155220	230780	230752	230752
122	Hub (for Double Sprocket)	230793	230793	230793	230793	230793
123	Chain Tensioner	201121	201121	201121	201121	201121
124	SMC Pillow Block	400335	400335	400335	400335	400335

Dual Drive, 5 Horsepower

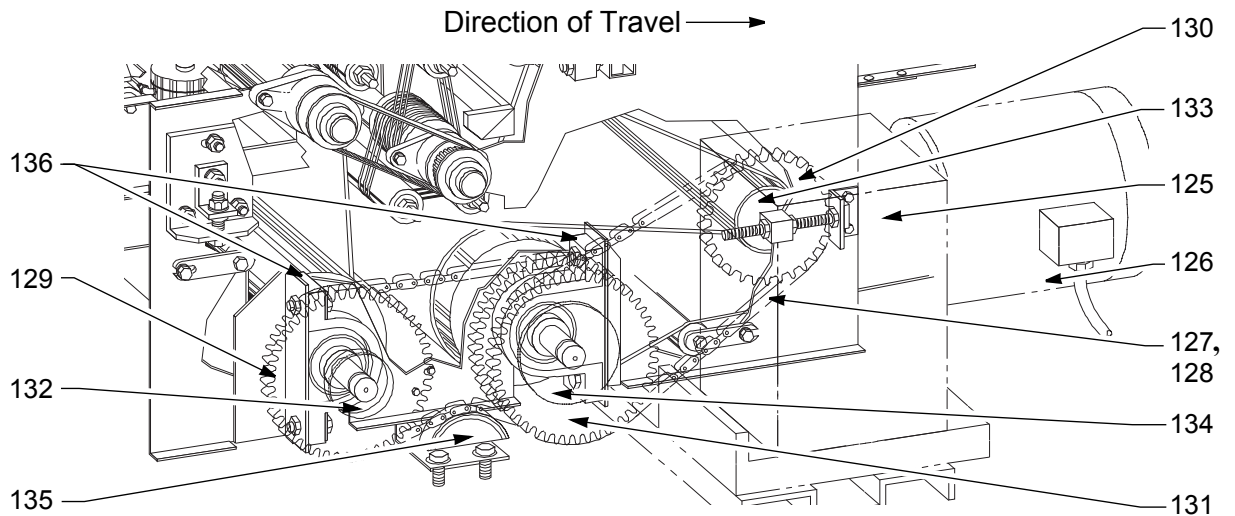

Figure I - 24 – Drive Assembly, Dual Drive Diverter

Table I - 25 – Dual Drive Diverter (RH & LH), 5 Horsepower

Key #	Part Description	Speed (FPM)				
		150	180	220	250	300
125	Gear Reducer (Right Hand)	811230	811228	811228	811224	811224
	Gear Reducer (Left Hand)	811229	811227	811227	811223	811223
126	Motor	330715	330715	330715	330715	330715
127	Chain	200987	200987	200987	200987	200987
128	Chain Coupler	7311060	7311060	7311060	7311060	7311060
129	Sprocket (PTO)	745644 (24tooth)	745644 (24tooth)	745644 (24tooth)	745644 (24tooth)	745644 (24tooth)
130	Sprocket (Driver)	745639 (19tooth)	745637 (17tooth)	745641 (21tooth)	745636 (16tooth)	745639 (19tooth)
131	Sprocket (Double)	749552 (24tooth)	749552 (24tooth)	749552 (24tooth)	749552 (24tooth)	749552 (24tooth)
132	Hub (for PTO Sprocket)	230782& 7758291	230782& 7758291	230782& 7758291	230782& 7758291	230782& 7758291
133	Hub (for Driver Sprocket)	230951	230951	230987	230953	230953
134	Hub (for Double Sprocket)	230793	230793	230793	230793	230793
135	Chain Tensioner	201121	201121	201121	201121	201121
136	SMC Pillow Block	400335	400335	400335	400335	400335

Dual Drive, 7.5 Horsepower

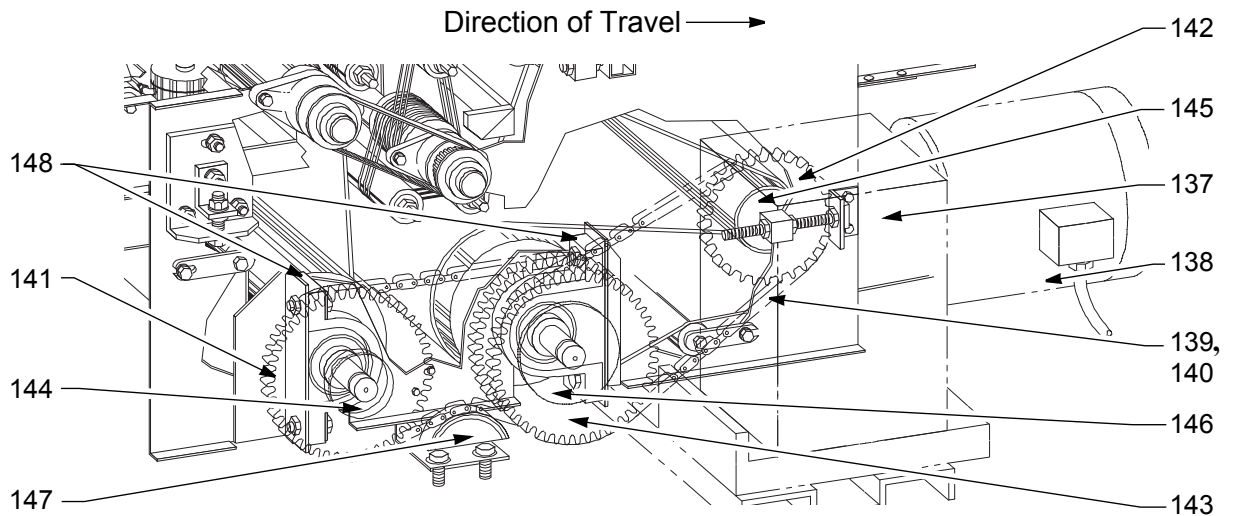

Figure I - 26 – Drive Assembly, Dual Drive Diverter

Table I - 27 – Dual Drive Diverter (RH & LH), 7.5 Horsepower

Key #	Part Description	Speed (FPM)				
		150	180	220	250	300
137	Gear Reducer (Right Hand)	811236	811234	811234	811232	811232
	Gear Reducer (Left Hand)	811235	811233	811233	811231	811231
138	Motor	330721	330721	330721	330721	330721
139	Chain	200989	200989	200989	200987	200987
140	Chain Coupler	200988	200988	200988	7311060	7311060
141	Sprocket (PTO)	745694 (23tooth)	745694 (23tooth)	745694 (23tooth)	745644 (24tooth)	745644 (24tooth)
142	Sprocket (Driver)	745689 (18tooth)	745687 (16tooth)	745691 (20tooth)	745636 (16tooth)	745639 (19tooth)
143	Sprocket (Double)	749553 (23tooth)	749553 (23tooth)	749553 (23tooth)	749552 (24tooth)	749552 (24tooth)
144	Hub (for PTO Sprocket)	230793	230793	230793	230782& 7758291	230782& 7758291
145	Hub (for Driver Sprocket)	230786	230786	230798	230951	230951
146	Hub (for Double Sprocket)	230806	230806	230806	230793	230793
147	Chain Tensioner	201122	201122	201122	201121	201121
148	SMC Pillow Block	400335	400335	400335	400335	400335

Dual Drive, 10 Horsepower

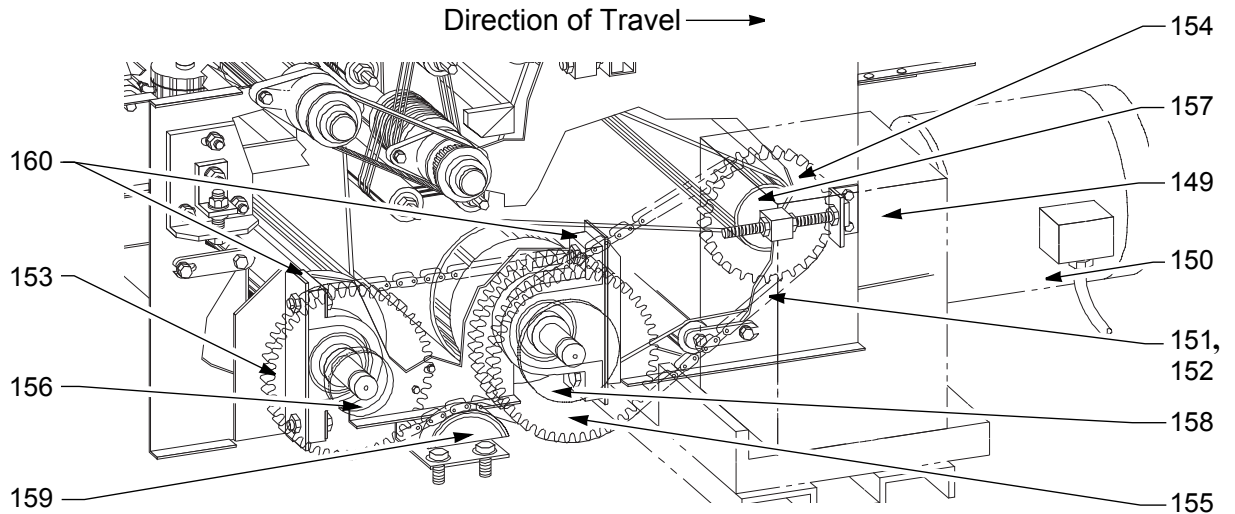

Figure I - 28 – Drive Assembly, Dual Drive Diverter

Table I - 29 – Dual Drive Diverter (RH & LH), 10 Horsepower

Key #	Part Description	Speed (FPM)				
		150	180	220	250	300
149	Gear Reducer (Right Hand)	–	811240	811240	811266	811266
	Gear Reducer (Left Hand)	–	811239	811239	811237	811237
150	Motor	–	330723	330723	330723	330723
151	Chain	–	200989	200989	200989	200989
152	Chain Coupler	–	200988	200988	200988	200988
153	Sprocket (PTO)	–	745694 (23tooth)	745694 (23tooth)	745694 (23tooth)	745694 (23tooth)
154	Sprocket (Driver)	–	745687 (16tooth)	745691 (20tooth)	745802 (15tooth)	745689 (18tooth)
155	Sprocket (Double)	–	749553 (23tooth)	749553 (23tooth)	749553 (23tooth)	749553 (23tooth)
156	Hub (for PTO Sprocket)	–	230793	230793	230793	230793
157	Hub (for Driver Sprocket)	–	230786	230798	230864	230786
158	Hub (for Double Sprocket)	–	230806	230806	230806	230806
159	Chain Tensioner	–	201122	201122	201122	201122
160	SMC Pillow Block	–	400335	400335	400335	400335

Dual Drive, 15 Horsepower

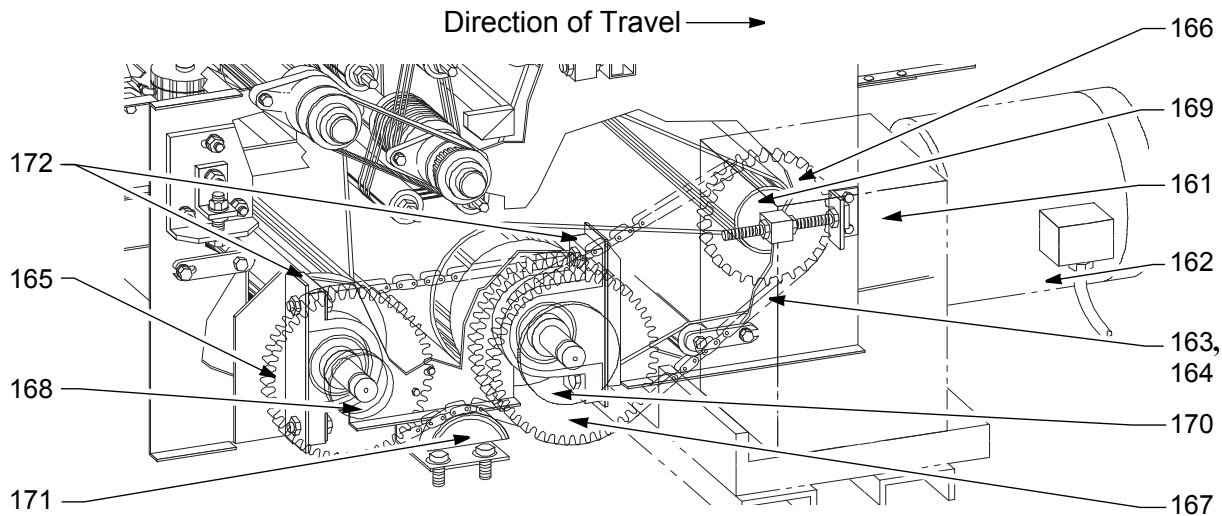

Figure I - 30 – Drive Assembly, Dual Drive Diverter

Table I - 31 – Dual Drive Diverter (RH & LH), 15 Horsepower

Key #	Part Description	Speed (FPM)				
		150	180	220	250	300
161	Gear Reducer (Right Hand)	–	–	811242	811244	811244
	Gear Reducer (Left Hand)	–	–	811241	811243	811243
162	Motor	–	–	330725	330725	330725
163	Chain	–	–	200989	200989	200989
164	Chain Coupler	–	–	200988	200988	200988
165	Sprocket (PTO)	–	–	745694 (23tooth)	745694 (23tooth)	745694 (23tooth)
166	Sprocket (Driver)	–	–	745691 (20tooth)	745802 (15tooth)	745803 (18tooth)
167	Sprocket (Double)	–	–	749553 (23tooth)	749553 (23tooth)	749553 (23tooth)
168	Hub (for PTO Sprocket)	–	–	230793	230793	230793
169	Hub (for Driver Sprocket)	–	–	230798	230866	230866
170	Hub (for Double Sprocket)	–	–	230806	230806	230806
171	Chain Tensioner	–	–	201122	201122	201122
172	SMC Pillow Block	–	–	400335	400335	400335

