

Product Manual
UniSort IV[®] Sortation Conveyor

Application Guidelines, Specifications, Installation
Procedures, Maintenance, Parts Identification, and
Product Index



To contact Intelligrated:
For service: Customer Service and Support (CSS)
Hotline 1-877-315-3400
On the World Wide Web: www.intelligrated.com

By mail:

Intelligrated
7901 Innovation Way
Mason, OH 45040

(513) 701-7300

Read these documents thoroughly before attempting to perform maintenance or repairs to the applicable Intelligrated conveyor system components or devices. Exercise extreme caution when working around moving and rotating conveyor equipment. Wear the proper clothing and safety equipment. DO NOT attempt to perform any maintenance until the equipment is de-energized, locked out and tagged out in accordance with established company procedures.

The information presented in these documents are correct at the time of publication. Intelligrated has made every effort to ensure that the information presented is correct and free from error. However, some errors or misprints may occur. Please contact Intelligrated with any corrections.

This document is copyrighted © 2010 by Intelligrated, all rights reserved. No Part of this manual may be reproduced and/or distributed to parties other than the customer and the customer's employees for whom it was originally produced.

The following terms are trademarks™ of Intelligrated; Accuglide™, BOSS™ UniSort™, EZ-set™. The following terms are registered trademarks® of Intelligrated; Accuzone®, UniSort®, E-Z Set®. Intelligrated® is a registered trademark.

Direct questions and comments concerning the information contained in this manual to:

Documentation Department
Intelligrated
7901 Innovation Way
Mason, OH 45040

Ph (513) 701-7300
Fax (513)701-7349

customerservice@intelligrated.com



Package Conveyors



 <p>Do Not Climb, Sit, Stand, Walk, Ride, or Touch the Conveyor at Any Time</p>	 <p>Do Not Perform Maintenance on Conveyor Until Electrical, Air, Hydraulic and Gravity Energy Sources Have Been Locked Out or Blocked</p>	 <p>Operate Equipment Only With All Approved Covers and Guards in Place</p>
 <p>Do Not Load a Stopped Conveyor or Overload a Running Conveyor</p>	 <p>Ensure That All Personnel Are Clear of Equipment Before Starting</p>	 <p>Allow Only Authorized Personnel To Operate or Maintain Material Handling Equipment</p>
 <p>Do Not Modify or Misuse Conveyor Controls</p>	 <p>Keep Clothing, Body Parts, and Hair Away from Conveyors</p>	 <p>Remove Trash, Paperwork, and Other Debris Only When Power is Locked Out and Tagged Out</p>
 <p>Ensure That ALL Controls and Pull Cords are Visible and Accessible</p>	 <p>Know the Location and Function of All Stop and Start Controls</p>	 <p>Report All Unsafe Conditions Jams should be cleared ONLY BY Authorized, Trained, Personnel</p>

POST IN PROMINENT AREA

Product Manual Issue and Revision Date(s)

1st Issue	December 2003
1st Revision	February 2006
2nd Revision	December 2006
3rd Revision	October 2007
4th Revision	August 2011

Product Manual Revision Summary

Revision Date	Manual Section(s)	Revision Summary
October 2007	Section H	Page H-5 - updated Figure H-1 and Table H-2
		Page H-5 - changed Belt C - 1/4" x 15 1/4" to Belt C - 1/4" x 15 3/4"
		Page H-8 - changed Belt E - 1/4" x 17 1/2" to Belt E - 1/4" x 20 1/4"
		Page H-9 - changed Belt G - 1/16" x 6 1/2" to Belt G - 1/4" x 6 1/8"
	Section I	Page 1-2 - updated Figure I-1
		Page 1-3 - updated Figure I-2
		Page 1-4 - updated part numbers
		Page 1-5 - updated part numbers
		Pages 1-12 thru 1-21 - updated part numbers
August 2011	Section H	Page H-5 update part numbers. Page H-8 update size for Belt D1 and Belt D2.

Product Manual Issue and Revision Date(s) ----- 1 - 4
 Product Manual Revision Summary ----- 1 - 4

Section A Product Summary

Section B Application Guidelines

Introduction ----- B - 1
 Basic Configuration ----- B - 2
 Operation ----- B - 4
 Diverter ----- B - 4
 End Diverter ----- B - 4
 Intermediate Diverter ----- B - 5
 Dual Snub Diverter ----- B - 6
 Take-Up/Idler Interface Diverter ----- B - 7
 Single Drive w/Diverter ----- B - 8
 Dual Drive w/Diverter ----- B - 9
 Sortation Rate ----- B - 10
 Applications ----- B - 11
 Product Consideration ----- B - 11
 Layout Consideration ----- B - 11

Section C Specifications

End Diverter ----- C - 1
 Frame ----- C - 1
 Bearings ----- C - 1
 Snub Roller ----- C - 1
 Number of Pop-Up Wheels (per row) ----- C - 1
 Pop-Up Wheels ----- C - 2
 Diverter Drive ----- C - 2
 Diverter Unit Belt Length ----- C - 2
 Pop-Up Actuator ----- C - 2
 Solenoid ----- C - 2
 Application ----- C - 2
 Intermediate Diverter ----- C - 3
 Frame ----- C - 3
 Bearings ----- C - 3
 Snub Roller ----- C - 3
 Number of Pop-Up Wheels (per row) ----- C - 3
 Pop-Up Wheels ----- C - 3
 Diverter Drive ----- C - 3
 Diverter Unit Belt Length ----- C - 4
 Pop-Up Actuator ----- C - 4
 Solenoid ----- C - 4
 Application ----- C - 4
 Diverter w/Dual Snub Rollers ----- C - 5
 Frame ----- C - 5
 Bearings ----- C - 5
 Snub Roller ----- C - 5
 Number of Pop-Up Wheels (per row) ----- C - 5

Pop-Up Wheels	C - 5
Diverter Drive	C - 6
Diverter Unit Belt Length	C - 6
Pop-Up Actuator	C - 6
Solenoid	C - 6
Application	C - 6
Take-Up Idler Interface	C - 7
Frame	C - 7
Bearings	C - 7
Snub Roller	C - 7
Number of Pop-Up Wheels (per row)	C - 7
Pop-Up Wheels	C - 7
Diverter Drive	C - 8
Take-Up Roller	C - 8
Idler Rollers	C - 8
Diverter Unit Belt Length	C - 8
Pop-Up Actuator	C - 8
Solenoid	C - 8
Application	C - 8
Diverter With Single Drive	C - 9
Frame	C - 9
Drive Pulley/Shaft	C - 9
Bearings	C - 9
Capacity	C - 9
Snub Roller	C - 9
Diverter Unit Belt Length	C - 9
Number of Pop-Up Wheels (Per Row)	C - 10
Pop-Up Wheels	C - 10
Diverter Drive	C - 10
Take-Up Roller	C - 10
Idler Rollers	C - 10
Power Unit Mounting	C - 10
Power Unit Drive Chain	C - 10
Chain Guard	C - 10
Motor	C - 10
Pop-Up Actuator	C - 10
Reducer	C - 10
Solenoid Valve	C - 10
Application	C - 10
Diverter With Dual Drive	C - 11
Frame	C - 11
Drive Pulley/Shaft	C - 11
Bearings	C - 11
Capacity	C - 11
Snub Roller	C - 11
Diverter Unit Belt Length	C - 11
Number of Pop-Up Wheels (Per Row)	C - 11
Pop-Up Wheels	C - 12
Diverter Drive	C - 12

Take-Up Roller	C - 12
Idler Rollers	C - 12
Diverter Assembly Drive	C - 12
Power Unit Mounting	C - 12
Drive Chain	C - 12
Chain Guard	C - 12
Motor	C - 12
Pop-Up Actuator	C - 12
Reducer	C - 12
Solenoid Valve	C - 12
Application	C - 12
Powered Belt On Roller (PBR)	C - 13
Intermediate Section	C - 13
Frame	C - 13
Carrying Rollers	C - 13
Belt Return Roller	C - 13
Application	C - 13
End Drive Unit - Series 800	C - 14
Frame	C - 14
Drive Pulley/Shaft	C - 15
Bearings	C - 15
Snub Roller	C - 15
Side Guards	C - 15
Capacity	C - 15
Power Unit Mounting	C - 15
Chain Guard	C - 15
Width	C - 15
Belt Length	C - 15
Motor	C - 15
Horsepower	C - 15
Power Supply	C - 15
Reducer	C - 15
Sprockets	C - 15
Service Factor	C - 15
Chain Guard	C - 15
Application	C - 16
Center Drive Unit - Series 800	C - 17
Frame	C - 17
Drive Pulley/Shaft	C - 17
Bearings	C - 17
Snub Roller	C - 17
Take-Up Roller/Shaft	C - 17
Capacity	C - 17
Power Unit Mounting	C - 17
Chain Guard	C - 17
Width	C - 18
Belt Length	C - 18
Take-Up Adjustment Range	C - 18
Motor	C - 18

Horsepower	C - 18
Power Supply	C - 18
Reducer	C - 18
Sprockets	C - 18
Service Factor	C - 18
Chain Guard	C - 18
Application	C - 18
End Take-Up Unit- Series 800	C - 19
Frame	C - 19
Take-Up Roller/Shaft	C - 19
Snub Roller	C - 19
Idler Roller	C - 19
Width	C - 19
Belt Length	C - 19
Application	C - 19
End Idler Unit - Series 800	C - 20
Frame	C - 20
Take-Up Roller/Shaft	C - 20
Snub Roller	C - 20
Width	C - 20
Belt length	C - 20
Application	C - 20
Return Belt Support Roller Bracket	C - 21
Frame	C - 21
Support Roller	C - 21
Application	C - 21
Section D Engineering Data	
System Application Guidelines and Formulas	D - 1
Sortable Items	D - 1
Item Size, Shape, Weight	D - 1
Product Alignment	D - 1
Gap Between Product	D - 1
Divert Side	D - 1
Divert Angle	D - 1
Product Diverting	D - 2
Transition Points	D - 2
Inclined Operation	D - 2
Take-Away Conveyors (After Sort Conveyors)	D - 2
Floor Supports	D - 4
Ceiling Hangers	D - 4
Return Belt Support	D - 4
Return Belt Angle	D - 4
Product Containment Guarding	D - 5
Personnel Safety Guarding	D - 5
Application Formulas	D - 6
Determining Sortation Rate - Cartons Per Minute (CPM)	D - 6
Determining Sorter Belt Speed - Feet Per Minute (FPM)	D - 6

Determining Live Load (Lbs. Per Foot) ----- D - 6
 Determining The Number of UniSort IV Drives ----- D - 7
 Calculating Effective Belt Pull ----- D - 8
 Effective Belt Pull - for even spacing between divert points ----- D - 8
 Effective Belt Pull - for un-even spacing between divert points----- D - 10
 Part 1 ----- D - 12
 Part 2 ----- D - 12
 Part 3 ----- D - 12
 Selecting the Power Unit Drive ----- D - 13
 Sortation Rate ----- D - 14

Section E Layout Dimensions

Basic Configurations ----- E - 1
 800 Series End Drive - End and Intermediate Type Diverter ----- E - 1
 Dimensions----- E - 1
 800 Series Center Drive and Dual Snub Type Diverter ----- E - 2
 Dimensions----- E - 2
 Single Drive w/Diverter ----- E - 3
 Dimensions----- E - 3
 Dual Drive w/Diverter ----- E - 4
 Dimensions----- E - 4
 Take-Up/Idler Interface ----- E - 5
 Dimensions----- E - 5

Section F Accessories

Section G Installation Procedures

Introduction ----- G - 1
 Accepting Shipment ----- G - 1
 Shortages or Errors ----- G - 1
 Lost or Damaged Shipment ----- G - 1
 Claims and Returns ----- G - 1
 Codes and Standards ----- G - 1
 Warning Signs ----- G - 2
 Safety Features ----- G - 2
 Parts Replacement ----- G - 2
 Factory Assistance ----- G - 2
 Installation Overview ----- G - 3
 Installation and Assembly Steps ----- G - 3
 Installing the Conveyor ----- G - 5
 Installing Floor Supports to Diverters ----- G - 5
 Installing Floor Supports to End Drive, End Take-up, and End Idler Units ----- G - 6
 Installing Floor Supports to Center Drive ----- G - 7
 Installing Ceiling Hangers ----- G - 7
 Installing Diverters ----- G - 7
 Installing Center Drive Unit ----- G - 8
 Installing Terminal Ends ----- G - 8
 Installing Powered Belt on Roller Intermediate Section ----- G - 8
 Installing Take-Away Conveyors ----- G - 11

Installing the Powered Carrying Belt	G - 13
Locating Return Belt Snub Rollers	G - 13
Return Belt Angle	G - 13
Return Belt Support Bracket with Roller	G - 14
Take-Up Pulley Initial Adjustment	G - 15
Threading the Belt	G - 19
Belt Cutting Procedure	G - 19
Belt Lacing Procedure	G - 19
Installing Air Piping and Connections	G - 20
Installing Drive Motor Soft Start	G - 21
Installing Electrical/Control Devices	G - 22
Installing Electrical Power and Control Device Wiring	G - 23
Initial Soft Start Adjustments	G - 24
Verifying Correct Drive Motor Rotation	G - 24
Initial Belt Tensioning and Tracking Adjustments	G - 24
Belt Tracking Adjustments	G - 25
Principles of Belt Tracking	G - 25
Final Adjustments	G - 27
Installing Product Containment Guarding	G - 28
Installing Personnel Safety Guards	G - 29
Final Soft Start Adjustments	G - 29
Drive Over-current Relay/Sensor Adjustments	G - 29
Air Pressure Adjustment	G - 29
Air Pressure Switch Adjustment	G - 29
Final Testing	G - 30
Checking Safety Features	G - 31
Installing Product Containment Guarding	G - 31
Installing Personnel Safety Guarding	G - 31
Final Installation Adjustments	G - 31
After Applying Electrical Power	G - 31

Section H Maintenance

Introduction	H - 1
Daily Inspections	H - 3
Weekly Inspections	H - 3
Monthly Maintenance	H - 4
Quarterly - 500 Hours Maintenance	H - 4
Semi-Annual; 1000 Hours Maintenance	H - 4
Belt and O-Ring Replacement for the Diverter Mechanism	H - 5
Belt A - 3/16" x 12"	H - 6
Belt B - 1/4" x 15 3/4"	H - 6
Belt C - 1/4" x 15 3/4"	H - 7
Belt D1 - 1/4" x 20 1/4"	H - 8
Belt D2 - 1/4" x 20 1/2"	H - 8
Belt E - 1/4" x 20 1/4"	H - 8
Belt F - 1/4" x 20 1/4"	H - 9
Belt G - 1/4" x 6 1/8"	H - 9
Belt H - 640-8M-30 HTD	H - 9

Belt I - 1/16" x 3/4" x 22 1/2" -----	H - 10
Belt J - 1/16" x 5 3/8" -----	H - 10
Adjustments -----	H - 11
Troubleshooting Belt Problems -----	H - 14
Section I Parts identification	
General Information -----	I - 1
Diverter Unit -----	I - 2
Diverter Spare Parts, Non-width Related -----	I - 4
Diverter Spare Parts Width Related (Conveyor Width) -----	I - 5
Diverter Belt Rollers -----	I - 5
Diverter Belt Roller Parts, Width Related -----	I - 7
Diverter Belt Roller Parts, Non-width Related -----	I - 7
Parts Not Illustrated -----	I - 8
Nondivert Sorter Modules -----	I - 8
Drive Components -----	I - 11
Drives Located at a Diverter Unit -----	I - 11
Single Drive -----	I - 11
Dual Drive -----	I - 11
Drives at Other Locations -----	I - 11
Single Drive, 1 Horsepower -----	I - 12
Single Drive Diverter (RH & LH), 1 Horsepower -----	I - 12
Single Drive, 1.5 Horsepower -----	I - 13
Single Drive, 2 Horsepower -----	I - 14
Single Drive, 3 Horsepower -----	I - 15
Single Drive, 5 Horsepower -----	I - 16
Single Drive, 7.5 Horsepower -----	I - 17
Dual Drive, 2 Horsepower -----	I - 18
Dual Drive, 3 Horsepower -----	I - 19
Dual Drive, 5 Horsepower -----	I - 20
Dual Drive, 7.5 Horsepower -----	I - 21
Dual Drive, 10 Horsepower -----	I - 22
Dual Drive, 15 Horsepower -----	I - 23
Section J Product Index	
UniSort IV Medium Speed -----	J - 1

SECTION A: PRODUCT SUMMARY

Overview:	<p>The UniSort IV is a belt-powered sortation conveyor using modular pop-up wheel type diverter assemblies to effect the sorting of the product.</p> <p>The diverter assemblies are designed for use with the Series M, High Speed Powered Belt Roller (PBR) Intermediate sections. The intermediate sections are located in-line with pop-up wheel diverter assemblies for transporting product to the diverters. Diverting is accomplished by a air cylinders causing the diverting wheels to pop-up, allowing the product to be diverted onto the take-away conveyor.</p> <p>Take-away conveyors are either powered or gravity skate wheel types depending on the mainline sorter (PBR) belt speed.</p>
General:	Belt driven, pop-up diverters
Configuration:	Single sided with left or right divert sides
Operation Mode:	Transportation
Speeds (ft./min.):	150, 180, 220, 250, and 300 fpm Increases with each row of pop-up wheels
Sort Rate:	31 to 133 cartons per minute (CPM) possible. (Actual rate dependant on product dimensions, gap between product, and belt speed.)
Product Handled:	Length: 9" - 40" Width: 6" - 30" Height: 2" minimum Weight: 2 lbs. - 75 lbs.
Number of Diverts:	7 maximum for 800 series applications 8 maximum for single drive 15 maximum for dual drive NOTE: 570 lb. maximum pull per belt.
Maximum Sorter Length:	Maximum length determined by the allowable number of diverts per sorter drive belt, minimum allowable divert center spacing and 570 lb. maximum pull allowed per belt.
Length/Number of Diverts Extending:	Take-up/Idler interface diverter assembly allows connecting two sorter belts with each belt having its own drive. Dual drive is used to power two separate belts, i.e., an upstream belt and a downstream belt.
Divert Angle:	45 degrees
Divert Centers:	Minimum of 2 X intermediate section width + 30"
Widths:	
PBR Sections:	15", 21", 27", 33"
Diverter:	18", 24", 30", 36"
Belt:	12", 18", 24", 30"
Product Alignment:	Aligned to divert side before inducting onto sorter
Gap Between Product:	18" minimum

Elevation (minimum):	18-1/8" to 31" depending on drive type and power unit horsepower		
Drive Types:	800 Series H.S. End (1.0 - 7.5 HP) 800 Series H.S. Center (1.0 - 7.5 HP) Single drive with built in Diverter (1.0 - 7.5 HP) Dual drive with built in Diverter (2.0 - 15.0 HP)		
Maximum Belt Pull:	570 lb. for 800 Series End and Center drive applications 570 lb. for single drive applications 1140 lb. for dual drive applications		
Drive Unit Dimensions with Power Unit:	<i>See Table A-1.</i>		
Diverter Assembly Types - Dimensions:	Type	Length	Depth
	End Diverter	30"	18 1/8"
	Intermediate Diverter	30"	18 1/8"
	Dual Snub Diverter	30"	18 1/8"
	Take-up/Idler Interface Diverter	30"	18 1/8"
	Side Mounted single Drive w/Diverter	30"	21 1/8"
	Side Mounted Dual Drive w/Diverter	40"	22 1/16"
Drive for Diverter:	Via power take-off (PTO) from powered sorter belt		
PBR Sections:	PBR Type Series M, High Speed Formed channel, 5" X 1-1/4" X 10 ga. 1.9" rollers, high speed bearings, 8" centers, set high		
Belting:	Friction top (FS X FS) 125 psi, clipper lacings		
Return Belt Support Roller:	Required if more than 10' between diverters; 1.9" roller with high speed bearing and mounting bracket		
Floor Supports:	Type FSM for diverter units; Type FSMU4 for intermediate sections		
Ceiling Hangers:	Type CHA for intermediate sections only Special for divert sections		
Take-Aways:	45 degree junction and 90 degree spur curve gravity skate wheel & powered types Power recommended for UniSort IV speed of 150 fpm		
Air Supply:	80 psi for pop-up cylinders		
Air Consumption:	Sort rate (CPM) X .0164 CFM		
Power Supply:	230/460 VAC for drive motor; 120 VAC for divert solenoid		

Table A.1 Drive Unit Dimensions with Power Unit

End Drive w/Underhung Power Unit			Center Drive w/Underhung Power Unit		
800 Series H.S.			800 Series H.S.		
Reducer	1 to 5 HP	7.5 HP	Reducer	1 to 5 HP	7.5 HP
#17	29" L x 20 3/8" D	-	#17	69 1/2" L x 18 1/8" D	-
#26	30 1/4" L x 22 1/4" D	-	#26	66 13/16" L x 18 1/8" D	-
#37	35 1/2" L x 26" D	-	#37	73 9/16" L x 23 1/8" D	-
#450 RH	-	39 1/4" L x 27" D	#450 RH	-	77 5/16" L x 23 1/2" D
#450 LH	-	39 1/4" L x 27" D	#450 LH	-	77 5/16" L x 25 1/2" D

End Drive w/Side Mounted Power Unit			Diverter Unit w/Side Mounted Power Unit												
800 Series H.S.			Reducer	HP Single Drive						HP Dual Drive					
Reducer	1 to 5 HP	7.5 HP		1	1.5	2	3	5	7.5	2	3	5	7.5	10	15
#17	27 5/8" L x 11 1/2" D	-	#210	x	x										
#26	28 7/8" L x 13 1/4" D	-	#260		x	x	x			x	x				
#37	36" L x 16 1/4" D	-	#320			x	x			x	x				
#450 RH	-	38 1/4" L x 17 5/8" D	#380				x	x		x	x	x			
#450 LH	-	38 1/4" L x 19 5/8" D	#450					x	x		x	x	x		
			#520						x				x	x	x
			#60												x
			Dim.	30" L x 21 5/8" D						40" L x 22 1/16" D					



SECTION B: APPLICATION GUIDELINES

Introduction

The UniSort IV is a belt-powered sortation conveyor using modular pop-up wheel type diverter assemblies to effect the sorting of the product.

A series of “O” rings function to power each pop-up wheel within two rows of pop-up wheels. The “O” rings connected to a multiple grooved pulley drum also power the three top carrying rollers for continuing the transportation of undiverted product. The speed of each row of pop-up wheel increases progressively for achieving positive diverting of the product.

The return portion of the PBR belt can be from or to a snub roller in the PBR intermediate section routed from an adjacent diverter assembly. In either case, an adjustable snub roller is provided in the power part of all diverter assembly except for the Take-Up/Idler Interface Type diverter.

The diverter assemblies are designed for use with the Series M, High Speed Powered Belt Roller (PBR) Intermediate sections. The intermediate sections are located in-line with pop-up wheel diverter assemblies for transporting product to the diverters. Diverting is accomplished by a air cylinders causing the diverting wheels to pop-up, allowing the product to be diverted onto the take-away conveyor.

The UniSort IV diverter assemblies have been designed to allow flexibility in laying out a UniSort IV sorter. For example, the Take-Up/Idler Interface Diverter allows a sortation line to be extended by permitting two separate powered belts to be interfaced at a diverter (divert point).

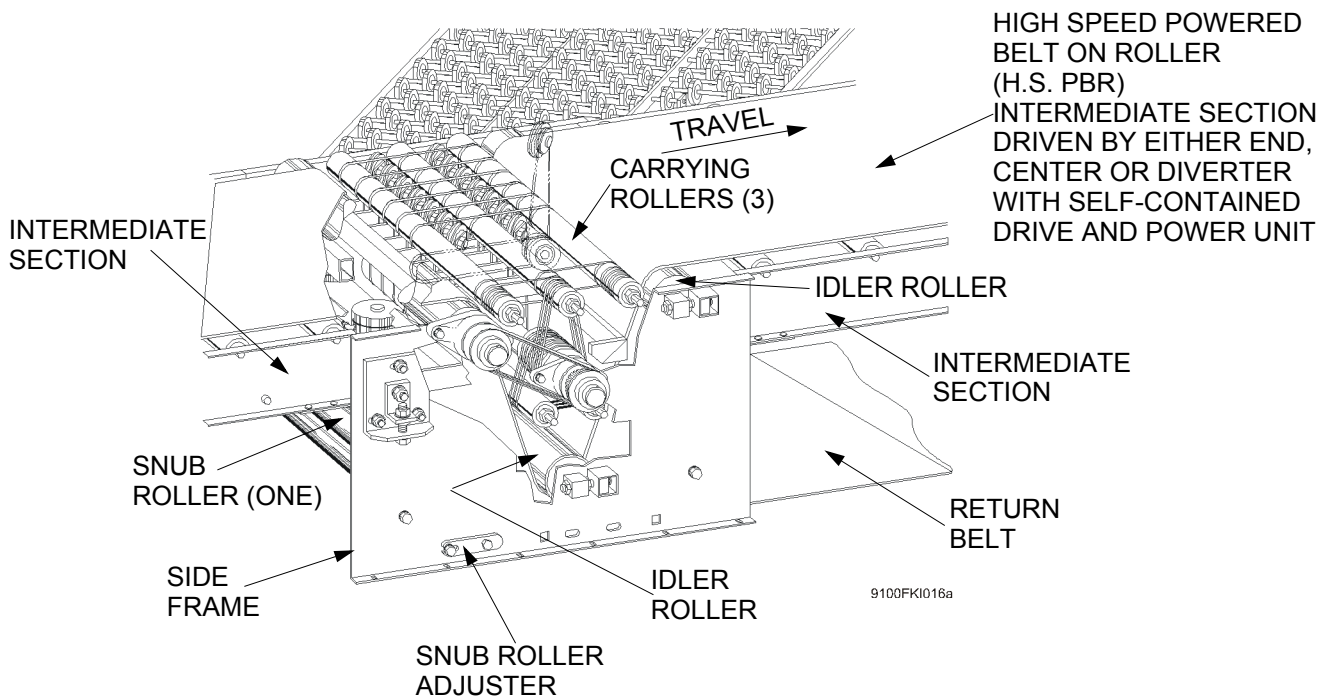

Figure B - 1 End Diverter Assembly Shown

Basic Configuration

To meet a wide range of sortation system performance requirements, the UniSort IV is available with four different drive unit types:

- 800 Series End Drive
- 800 Series Center Drive
- Single Drive
- Dual Drive

The single and dual drive types are built into the diverter unit. Power unit horsepower ranges from 1 to 15 HP; powered belt speeds from 150 to 300 fpm.

Take-away conveyors are either powered or gravity skate wheel types depending on the mainline sorter (PBR) belt speed.

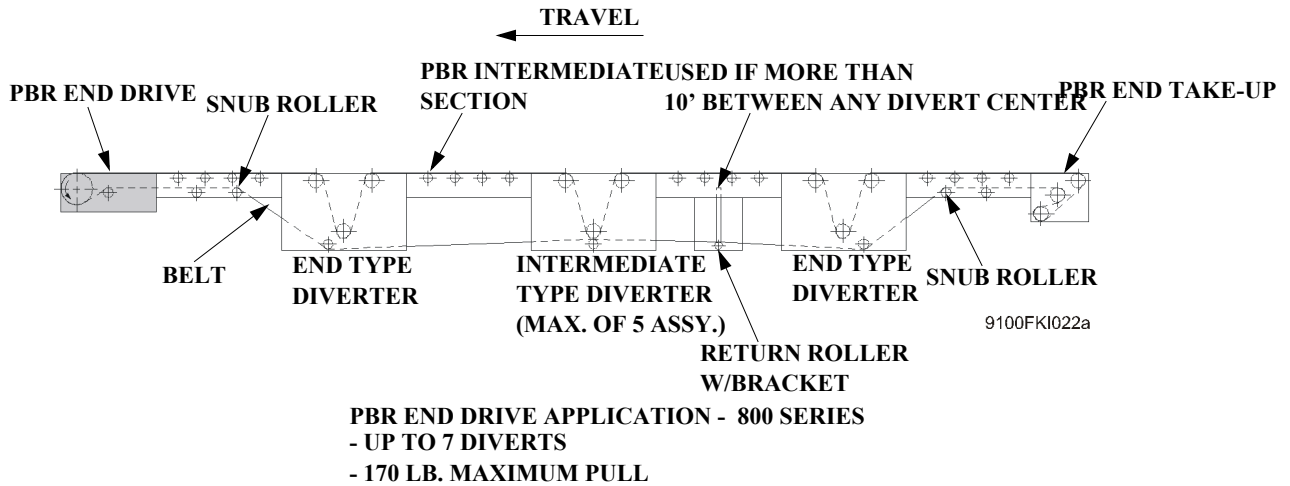

Figure B - 2 800 Series End Drive and Intermediate Type Diverter

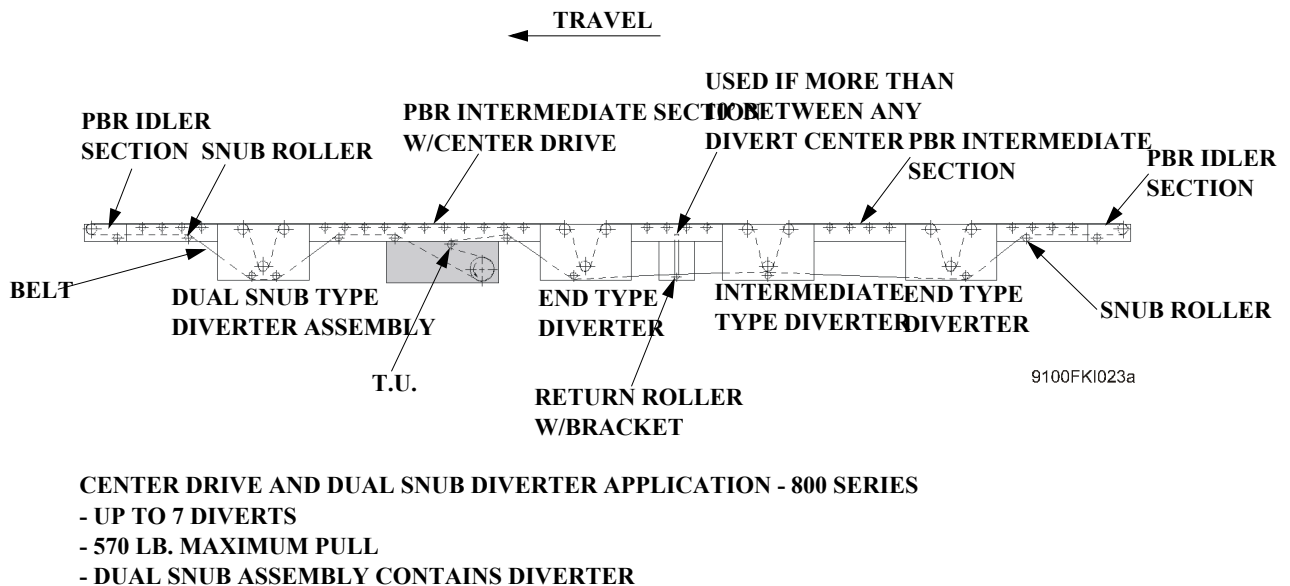
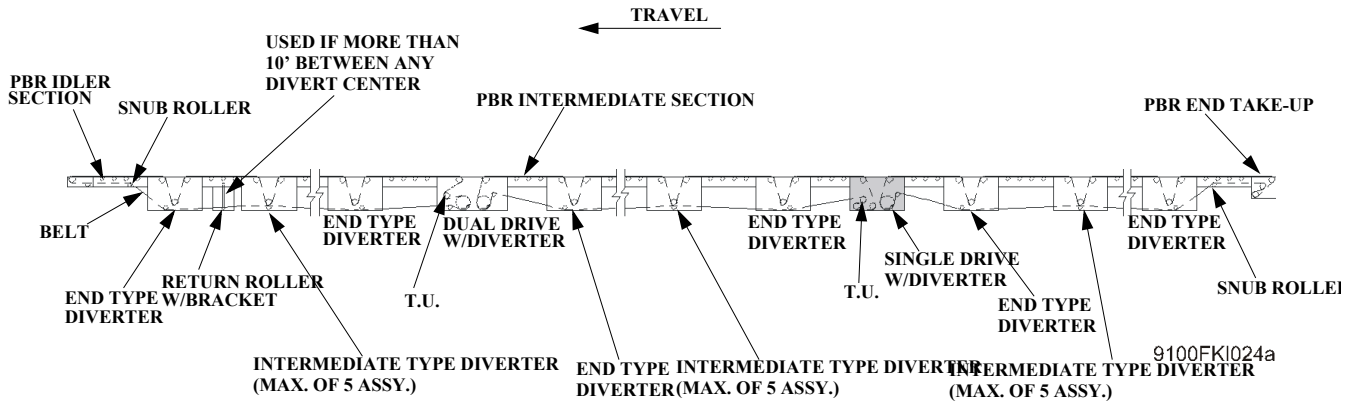

Figure B - 3 800 Series Center Drive and Dual Snub Type Diverter



SINGLE DRIVE W/DIVERTER ASSEMBLY APPLICATION

- UP TO 7 DIVERTS PER SINGLE DRIVE
- 570 LB. MAXIMUM PULL PER SINGLE DRIVE
- CONTAINS OWN DIVERTER SECTION

Figure B - 4 Single Drive w/Diverter

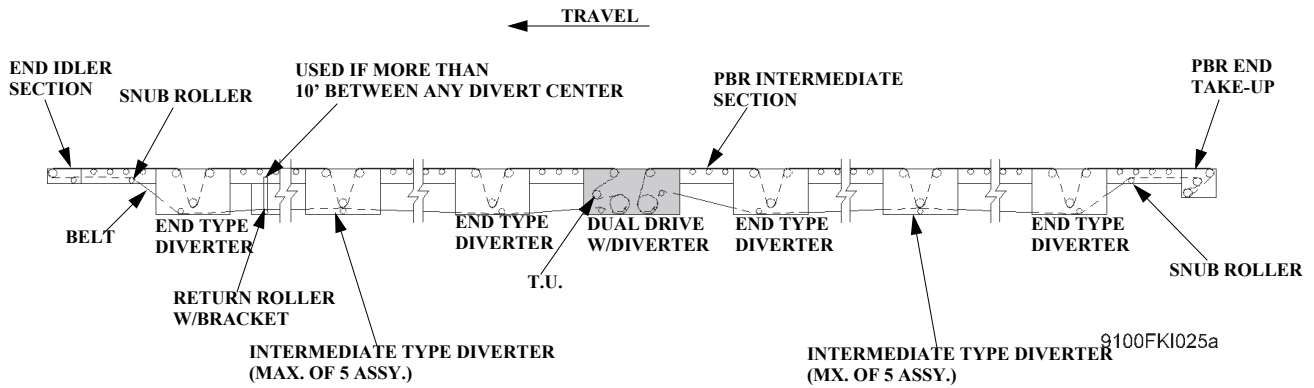

DUAL DRIVE APPLICATION

- UP TO 7 DIVERTS PER DRIVE - 14 W/DUAL DRIVE
- 570 LB. MAXIMUM PUL PER DRIVE - 1140 LB. W/DUAL DRIVE
- CONTAINS OWN DIVERTER SECTION

Figure B - 5 Dual Drive w/Diverter

Operation

The following information is intended to provide assistance in applying the UniSort IV Sortation Conveyor. You should be familiar with the UniSort IV Product Summary as shown in Section A.

Diverter

The UniSort IV has been designed to accommodate a wide range of sortation performance and layout requirements. The modular (building blocks) design approach of the various diverter and drive unit assemblies aims at achieving these requirements.

There are six different types of UniSort IV diverters. Each type is designed to meet a UniSort IV operational requirement:

- End Diverter
- Intermediate Diverter
- Dual Snub Diverter
- Take-Up/Idler Interface Diverter
- Single Drive w/Diverter
- Dual Drive w/Diverter

End Diverter

The End diverter is used adjacent to a drive terminal end or adjacent to a Take-Up/Idler Interface diverter on the downstream side.

The End diverter uses one return belt snub roller (G251GHS) which is field installed on the End diverter's upstream side if the adjacent terminal end is located upstream. Otherwise, the return belt snub roller is located on the downstream side.

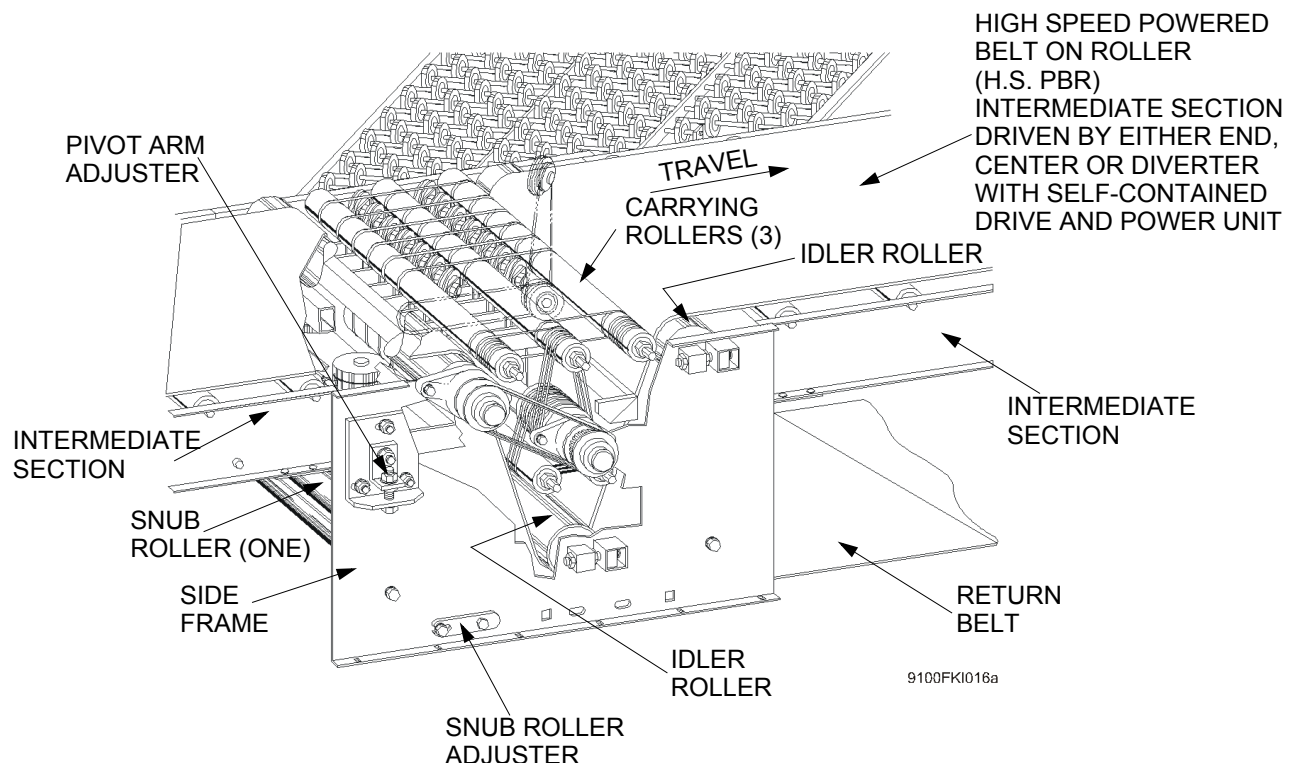

Figure B - 6 End Diverter

Intermediate Diverter

The Intermediate diverter is used adjacent to the End diverter or adjacent to another Intermediate diverter.

The Intermediate diverter uses one return belt idler roller (G196GHS) and is always located in the bottom middle of the diverter assembly to support the return run of the PBR belt.

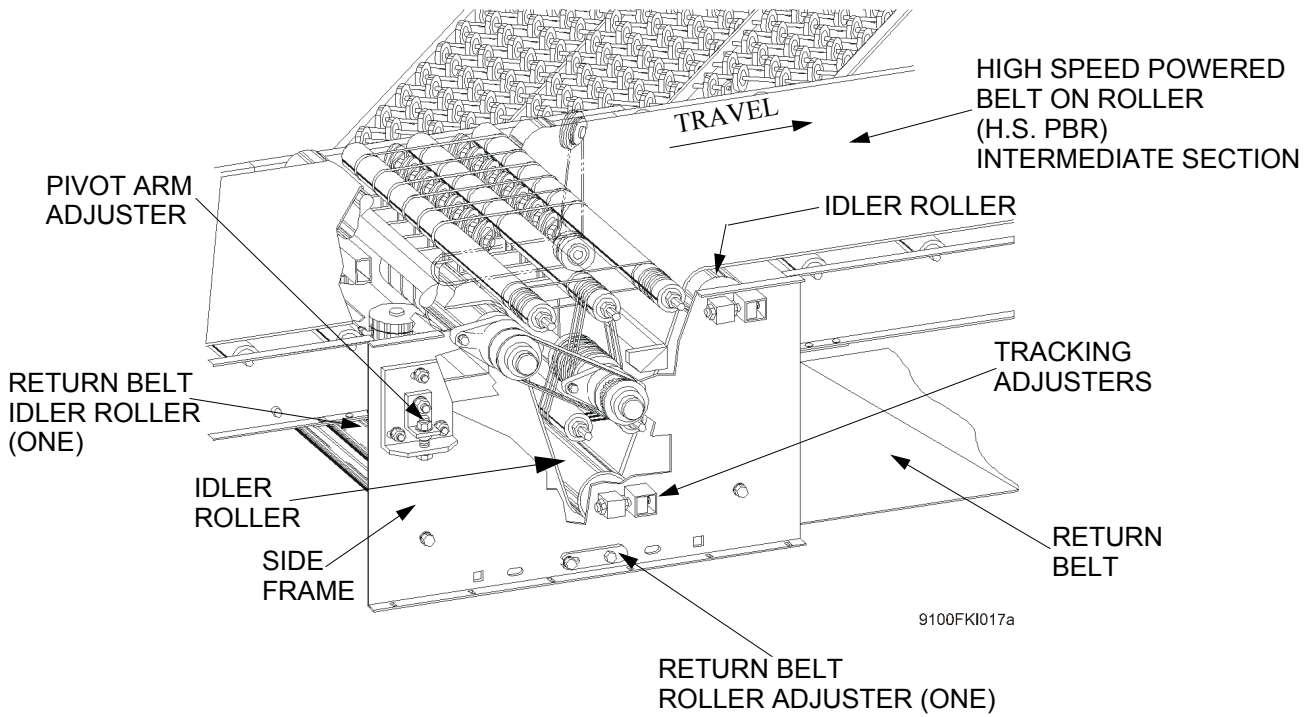

Figure B - 7 Intermediate Diverter

Dual Snub Diverter

The Dual Snub diverter is used when only one divert is required between a drive unit and a terminal end.

The Dual Snub diverter is supplied with two return belt snub rollers (G251GHS) located in the bottom of the diverter assembly on the upstream and downstream side.

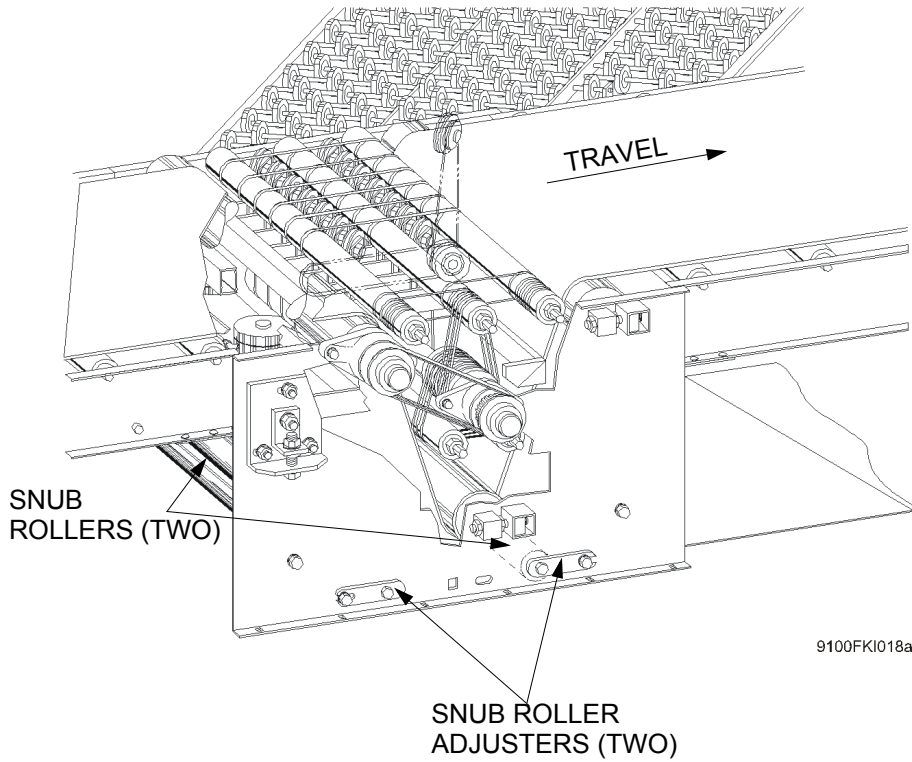
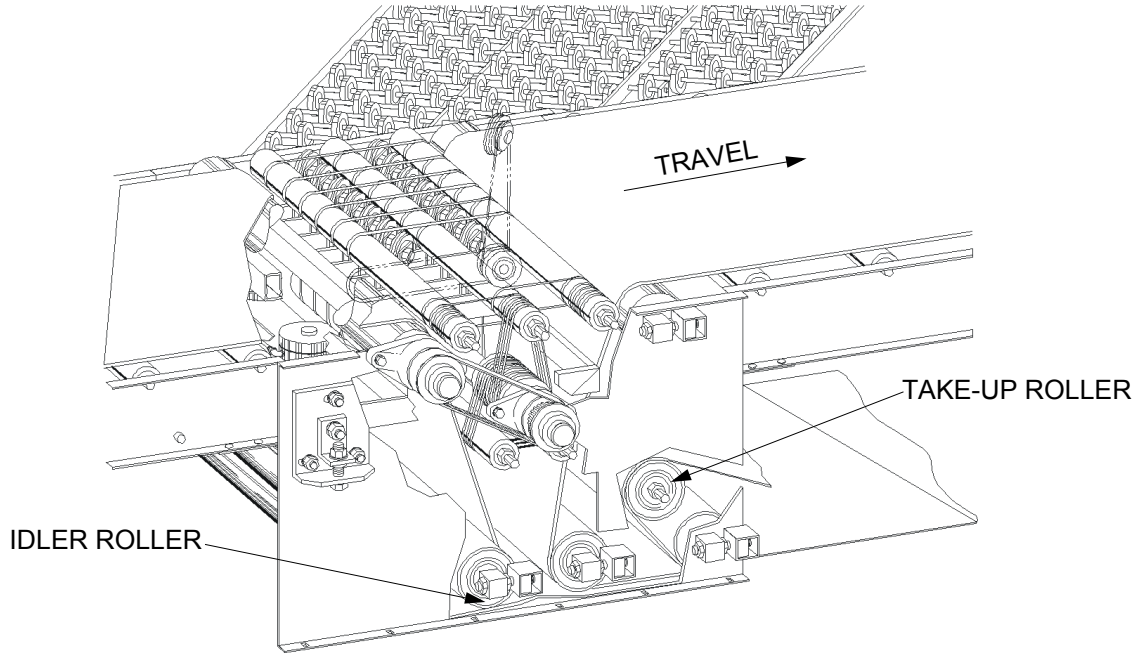

Figure B - 8 Dual Snub Diverter

Take-Up/Idler Interface Diverter

The Take-Up/Idler Interface diverter is used to connect (interface) two PBR belts with each belt having its' own drive.

This diverter allows a UniSort IV to be extended with added diverts. It contains its' own diverter. An idler is contained on the upstream side with a PTO for driving the diverter mechanism. The Take-Up is located on the downstream side.



9100FKI019a

Figure B - 9 Take-Up/Idler Interface Diverter

Single Drive w/Diverter

This diverter is used to drive up to seven diverts located upstream from the single drive. The diverter has a maximum pull of 570 lbs.

Note: With the included diverter, up to 8 diverts can be powered.

The Single Drive with diverter has a take-up for separately driven downstream diverts. Downstream diverts are driven by another drive type such as an 800 Series End drive or Dual Drive w/diverter.

Power units for this diverter range from 1 to 7-1/2 HP for belt speeds of 150 to 300 fpm.

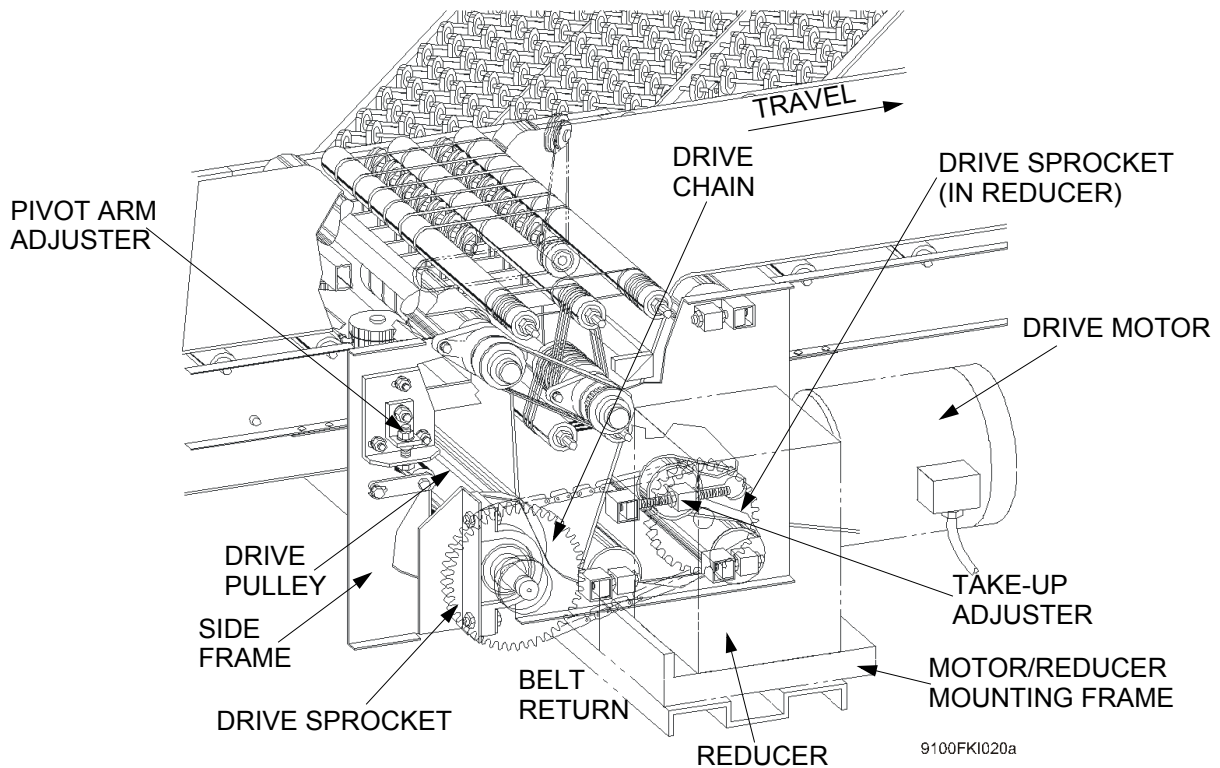

Figure B - 10 Single Drive w/Diverter

Dual Drive w/Diverter

The Dual Drive w/diverter is used to drive up to seven upstream diverts and up to seven downstream diverts.

Note: With the included diverter, up to 15 diverts can be powered. The number of upstream and downstream diverts should be equal as possible.

Power units for this diverter range from 2 to 15 HP for belt speeds of 150 to 300 fpm.

A Take-Up is included within the Dual Drive on the downstream side. A Take-Up must be provided on the upstream side.

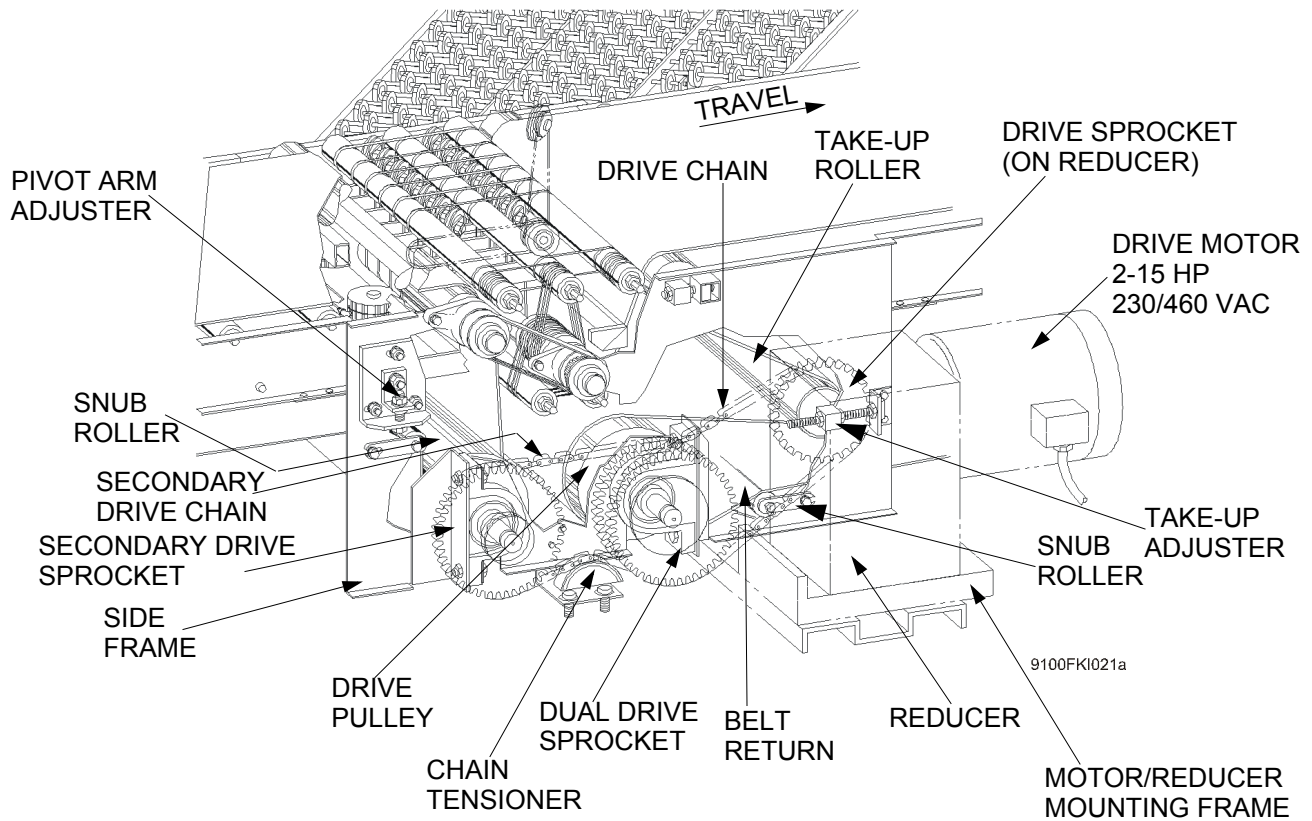

Figure B - 11 Dual Drive w/Diverter

Sortation Rate

Table B.1 Sortation Rate

Uniform Case Length (Inches)	Main Sort Line Speed - FPM				
	150	180	220	250	300
Delivery Rate - Cases / Minute					
9	66	80	97	111	133
12	60	72	88	100	120
16	53	63	77	88	106
20	47	56	70	78	94
24	42	51	62	71	85
30	37	45	55	62	75
36	33	40	48	55	66
40	31	37	45	51	62

Note: The above rates are based on constant 18" gap between cases and all cases being the same length. Actual rates will depend on case length mix, induction system thru-put and availability of product at induct station.

Applications

Product Consideration

- Product must be capable of being conveyed.
- Minimum product length is nine (9) inches.
- Maximum conveyor load is 75 pounds per linear foot for occasion container.
- Containers must be capable of withstanding impact from diverters as product is diverted.
- Items for sorting must be aligned to the divert side before product reaches the sorter's infeed end.
- An minimum of 18" gap must be maintained between product to ensure reliable diverting.
- Two rows of pop-up wheels are skewed to effect a fixed 45 degree divert angle.
- The pop-up wheels must be in the full up position before the leading edge of the product reaches the diverter assembly.
- The UniSort IV should not be inclined.

Layout Consideration

- Two types of 2500 lb. capacity floor supports are used for supporting a UniSort IV.
- The diverter units should have a type FSM floor support located at each corner. (Two floor supports per diverter.)
- The PBR sections should have a type FSMU4 floor support located at any PBR section splice joint or for any continuous intermediate section length greater than 10 feet.
- Type CHA ceiling hangers are used for suspending the PBR sections. However, the diverter units may require an application engineered ceiling hanger in order to provide clearance for the take-away conveyor.
- To prevent product from being accidentally discharged off the UniSort IV, the type F; 5-1/2" high and the type G; 11" high closed type guarding should be used.
- Personnel safety guarding should be applied to following areas to prevent personal injury:
 - Pinch points
 - Diverter unit - top and bottom surfaces
 - Exposed sections of the carrying belt return run including edge and bottom surfaces.

SECTION C: SPECIFICATIONS

End Diverter

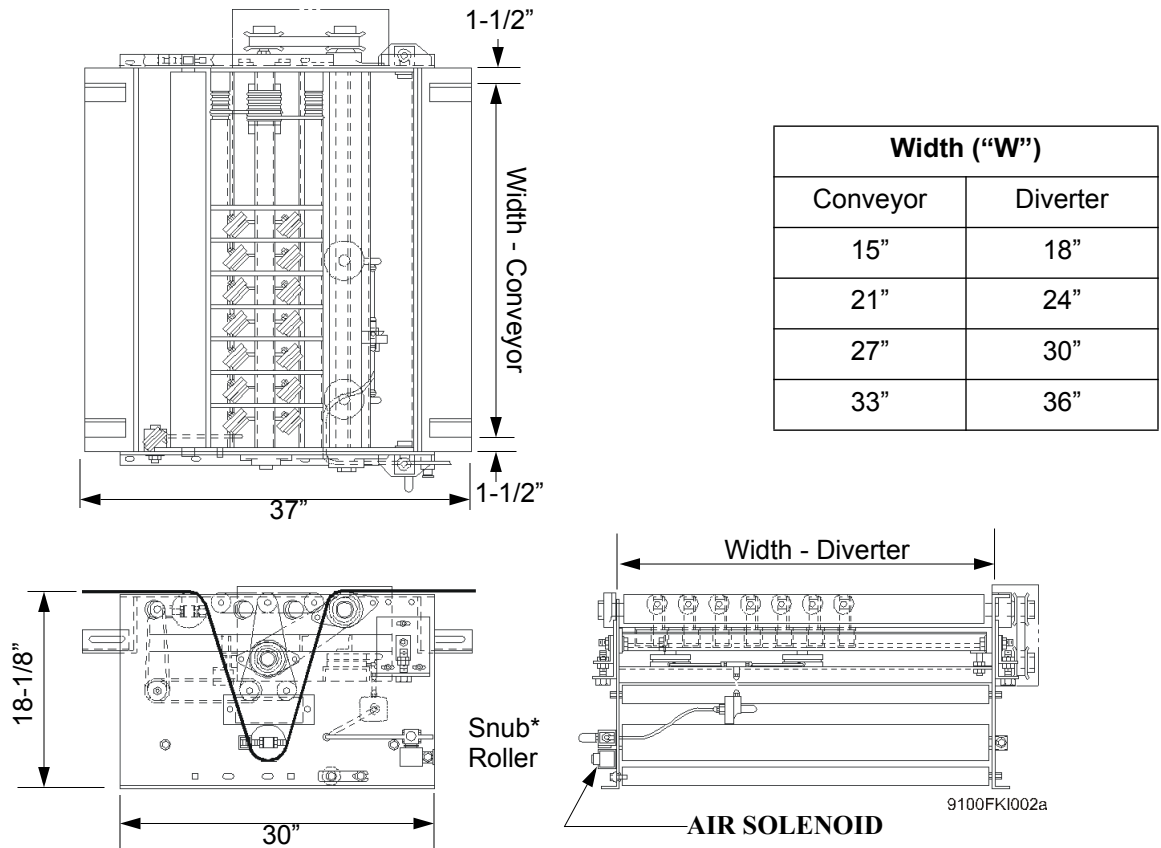

*Located on upstream or downstream side depending on layout.

Figure C - 1 End Diverter

Frame

18 1/8" deep x 10 ga. formed steel side plates 30" long; welded cross members. Powder-coated gray.

Bearings

Grease packed, precision bearing cartridge type w/2 bolt flange-type housing. For Diverter Drive and PTO pulleys.

Shielded roller bearings in pop-up wheels.

Snub Roller

No. G251 GHS. Adjustable for belt tracking, (one used). Field installed.

Number of Pop-Up Wheels (per row)

4 for 15" "W", 5 for 21" "W", 6 for 27" "W", and 7 for 33" "W".

Pop-Up Wheels

2.125" diameter, "O" ring driven, mounted on 37.5° fixed angle. Speed increases with each row.

Diverter Drive

- (1) Via PTO from Intermediate Section Belt.
- (2) "O" ring type belts drive individual rollers and Pop-up wheels.

Diverter Unit Belt Length

Add 8' 0".

Pop-Up Actuator

Air cylinder type. 80 psi; 5/16" stroke.

Solenoid

120 VAC.

Application

Used adjacent to a drive or to a take-up/idler terminal end Return belt snub roller(s) located at installation.

Intermediate Diverter

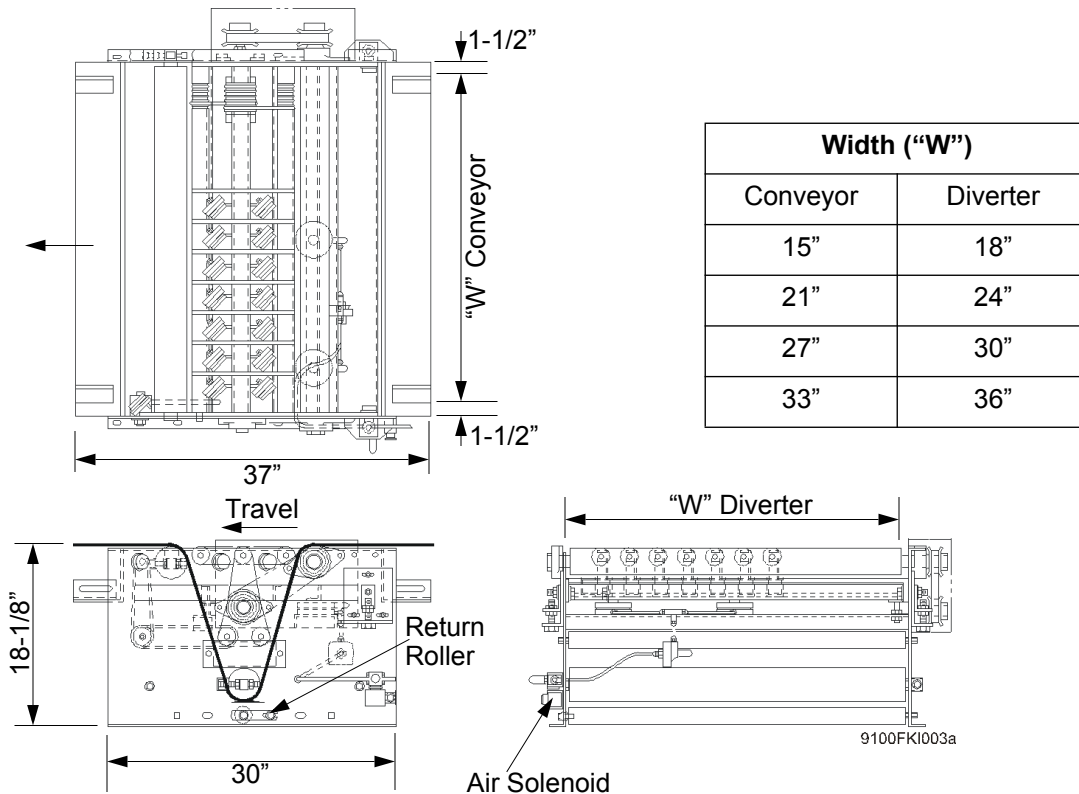

Figure C - 2 Intermediate Diverter

Frame

18 1/8" deep x 10 ga. formed steel side plates 30" long; welded cross members. Powder-coated gray.

Bearings

Grease packed, precision bearing cartridge type w/2 bolt flange-type housing. For Diverter Drive and PTO pulleys.

Shielded roller bearings in pop-up wheels.

Snub Roller

No. G196GHS roller. Adjustable for belt tracking, (one used). Field installed.

Number of Pop-Up Wheels (per row)

4 for 15" "W", 5 for 21" "W", 6 for 27" "W", and 7 for 33" "W".

Pop-Up Wheels

2.125" diameter, "O" ring driven, mounted on 37.5° fixed angle. Speed increases with each row.

Diverter Drive

- (1) Via PTO from Intermediate Section Belt.
- (2) "O" ring type belts drive individual rollers and Pop-up wheels.

Diverter Unit Belt Length

Add 8' 0".

Pop-Up Actuator

Air cylinder type. 80 psi; 5/16" stroke.

Solenoid

120 VAC.

Application

Used between two End type diverters or between an End type and another Intermediate, or between two other Intermediate type diverters.

Diverter w/Dual Snub Rollers

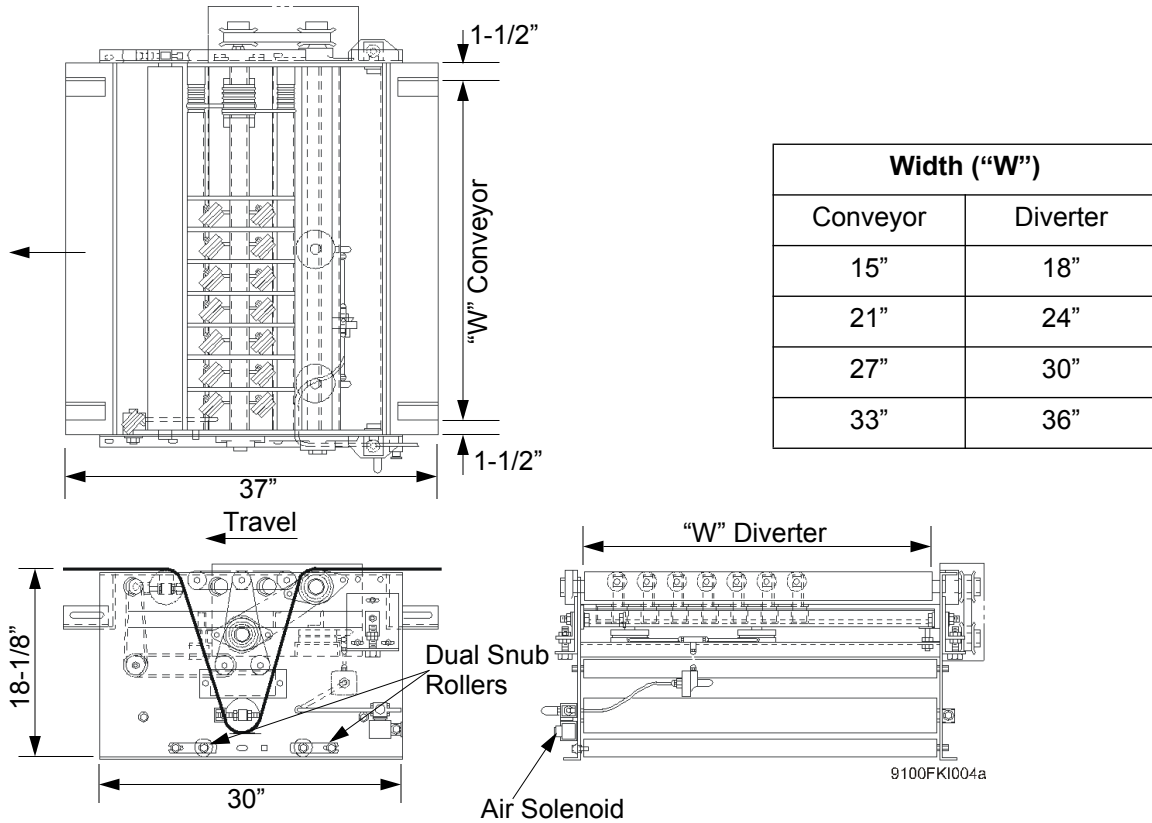

Figure C - 3 Diverter w/Dual Snub Rollers

Frame

18 1/8" deep x 10 ga. formed steel side plates 30" long; welded cross members. Powder-coated gray.

Bearings

Grease packed, precision bearing cartridge type w/2 bolt flange-type housing. For Diverter Drive and PTO pulleys.

Shielded roller bearings in pop-up wheels.

Snub Roller

No. G251GHS roller. Adjustable for belt tracking, (two used). Field installed.

Number of Pop-Up Wheels (per row)

4 for 15" "W", 5 for 21" "W", 6 for 27" "W", and 7 for 33" "W".

Pop-Up Wheels

2.125" diameter, "O" ring driven, mounted on 37.5° fixed angle. Speed increases with each row.

Diverter Drive

- (1) Via PTO from Intermediate Section Drive Belt.
- (2) "O" ring type belts drive individual rollers and Pop-up wheels.

Diverter Unit Belt Length

Add 8' 0".

Pop-Up Actuator

Air cylinder type. 80 psi; 5/16" stroke.

Solenoid

120 VAC.

Application

Used when only one divert is to be located between drive unit and terminal end.

Take-Up Idler Interface

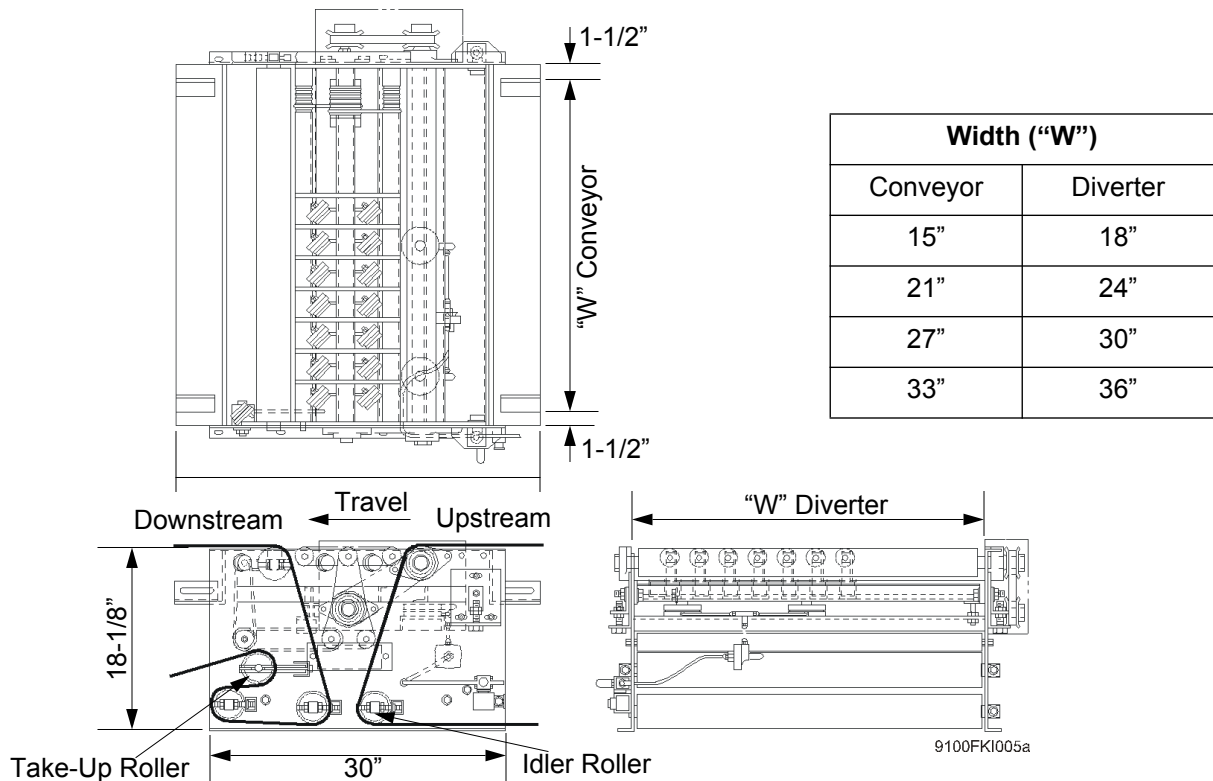

Figure C - 4 Take-Up/Idler Interface

Frame

18 1/8" deep x 10 ga. formed steel side plates 30" long; welded cross members. Powder-coated gray.

Bearings

Grease packed, precision bearing cartridge type w/2 bolt flange-type housing. Mounted on Diverter Drive Pulley, "PTO" pulley, and 3 1/2" dia. Take-up rollers.

Shield roller bearings in Pop-up wheels.

Snub Roller

No. G251GHS roller. Adjustable for belt tracking, (two used). Field installed.

Number of Pop-Up Wheels (per row)

4 for 15" "W", 5 for 21" "W", 6 for 27" "W", and 7 for 33" "W".

Pop-Up Wheels

2.125" diameter, "O" ring driven, mounted on 37.5° fixed angle. Speed increases with each row.

Diverter Drive

- (1) Via PTO from Intermediate Section Drive Belt.
- (2) "O" ring type belts drive individual rollers and Pop-up wheels.

Take-Up Roller

3 1/2" diameter. 7 1/2" Take-up Adjustment

Idler Rollers

3 1/2" diameter. 2" Tracking Adjustment

Diverter Unit Belt Length

Add 7' 0". Downstream: 3'-6" and Upstream: 3'-6".

Pop-Up Actuator

Air cylinder type. 80 psi; 5/16" stroke.

Solenoid

120 VAC.

Application

Used for connecting (interfacing) two belts with each belt having its' own drive unit.

Diverter With Single Drive

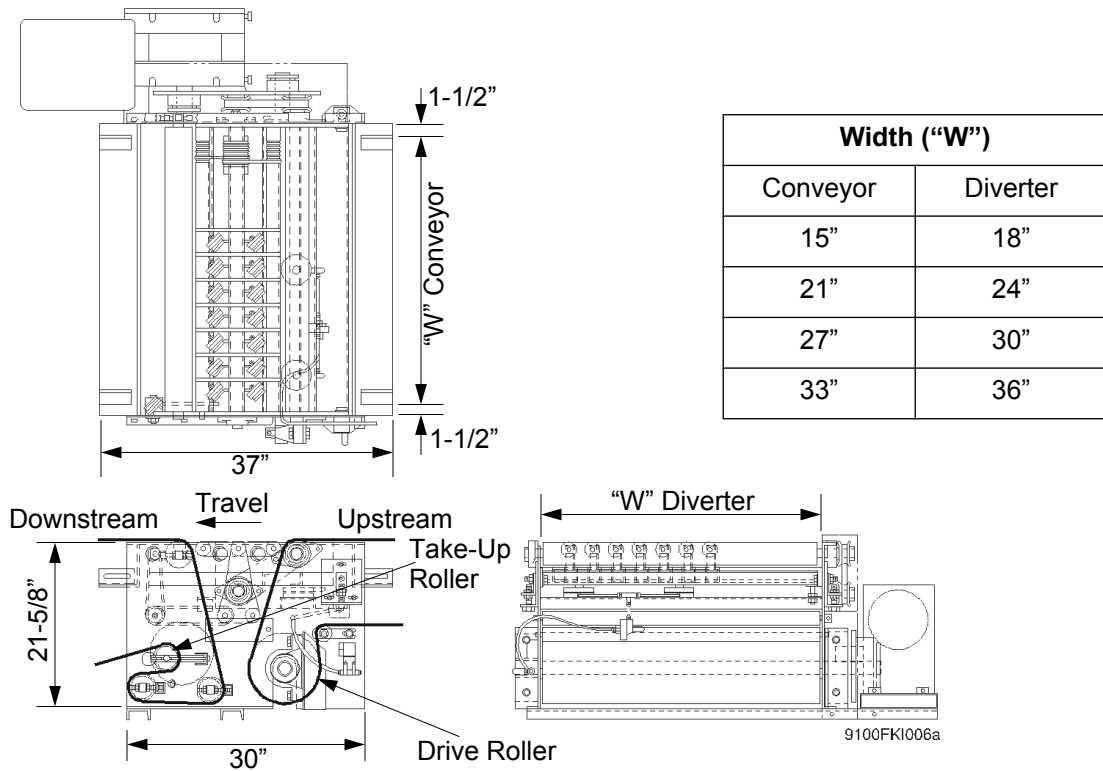

Figure C - 5 Diverter With Single Drive

Frame

21 5/8" deep x 10 ga. formed steel side plate, 30" long, with welded cross members. Powder-coated gray.

Drive Pulley/Shaft

8 5/8" diameter, lagged and edge crowned; keyed to 1 7/8" dia. CRS drive shaft.

Bearings

Grease-packed, precision bearing cartridge type w/2 bolt flange-type housing. For Diverter Drive and PTO pulleys.

Shielded roller bearings in Pop-up wheels.

Capacity

570 lbs. effective belt pull.

Snub Roller

No. 251GHS roller. Adjustable for belt tracking.

Diverter Unit Belt Length

Add 8' 0" downstream: 4'-3" and Upstream: 3'-9".

Number of Pop-Up Wheels (Per Row)

4 for 15" "W", 5 for 21" "W", 6 for 37" "W" and 7 for 33" "W".

Pop-Up Wheels

2.125 diameter, O ring driven, mounted on 37.5° fixed angle. Speed increases with each row.

Diverter Drive

- (1) Via PTO from Intermediate Section Drive Belt.
- (2) O ring type belts drive individual rollers and Pop-up wheels.

Take-Up Roller

3 1/2" diameter. 7 1/2" Take-up adjustment.

Idler Rollers

3 1/2" diameter. 2" Tracking adjustment

Power Unit Mounting

Side mounted.

Power Unit Drive Chain

RC-60 or RC-80. 1.4 min. service factor.

Chain Guard

Fully-enclosed, removable.

Motor

C-face totally enclosed fan-cooled (TEFC), 1750 rpm. Power supply 230/460

Pop-Up Actuator

Air cylinder type 80 psi; 5/16" stroke.

Reducer

Right angle worm gear. 1.25 min. service factor.

Solenoid Valve

120 VAC

Application

Used to power a single belt with up to seven diverts. has the Drive and Power unit included with the Diverter Unit. Take-up unit is included with Single Drive for downstream belt.

Diverter With Dual Drive

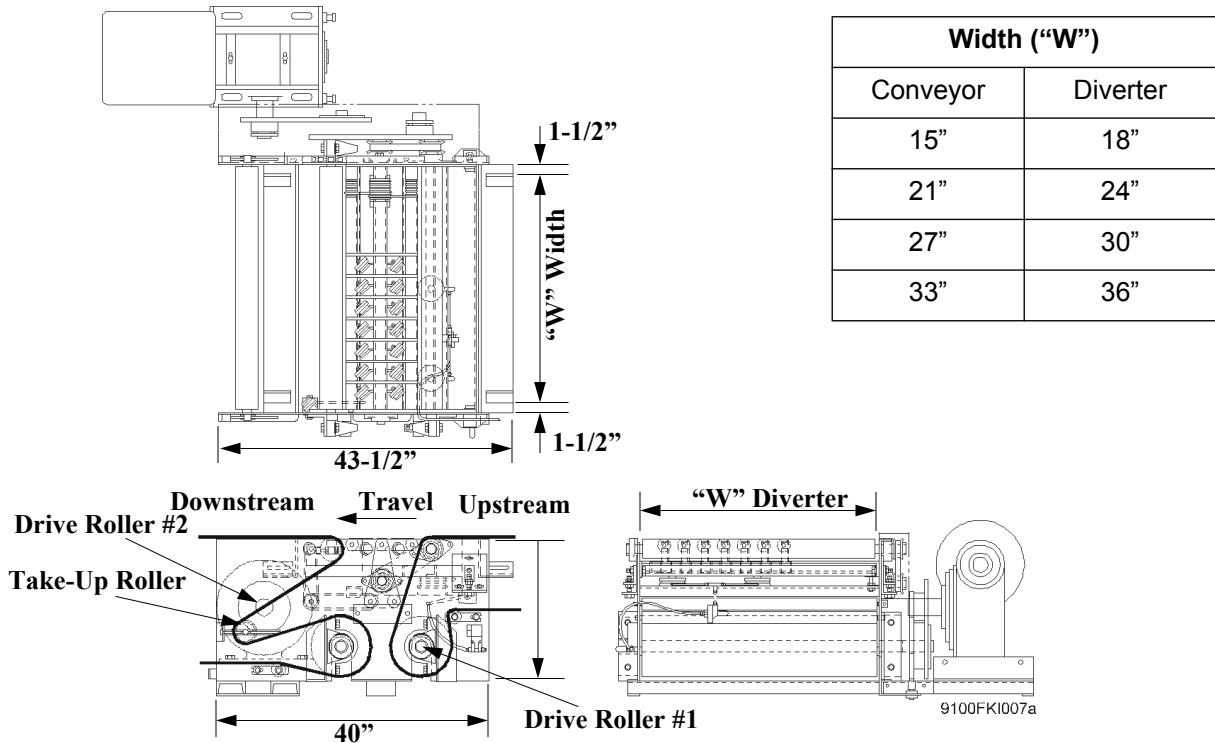

Figure C - 6 Diverter With Dual Drive

Frame

22 1/16" deep x 10 ga. formed steel side plates, 40" long, with welded cross members. Powder-coated gray.

Drive Pulley/Shaft

8 1/2" diameter, lagged and edge crowned, keyed to 1 7/8" dia. CRS drive shaft.

Bearings

Grease-packed, precision bearing cartridge type w/2 bolt flange-type housing. For Diverter Drive and PTO pulleys.

Shielded roller bearings in Pop-up wheels.

Capacity

1140 lbs. effective belt pull. (570 lbs. per belt).

Snub Roller

No. 251GHS roller. Adjustable for belt tracking.

Diverter Unit Belt Length

Add 9' 0". downstream: 5'-6" and Upstream 3'-6".

Number of Pop-Up Wheels (Per Row)

4 for 15" "W", 5 for 21" "W", 6 for 27" "W" and 7 for 33" "W".

Pop-Up Wheels

2.125 diameter, O ring driven, mounted on 37.5° fixed angle. Speed increases with each row.

Diverter Drive

- (1) Via PTO from Intermediate Section Drive Belt.
- (2) O ring type belts drive individual rollers and Pop-up wheels.

Take-Up Roller

3 1/2" diameter. 7 1/2" Take-up adjustment.

Idler Rollers

3 1/2" diameter. 2" Tracking adjustment

Diverter Assembly Drive

Via PTO from Powered Belt.

Power Unit Mounting

Side mounted.

Drive Chain

RC-80, 1.4 service factor.

Chain Guard

Removable, fully-enclosed.

Motor

C-face totally enclosed fan-cooled (TEFC), 1750 rpm. Power supply 230/460.

Pop-Up Actuator

Air Cylinder type, 80 psi; 5/16" stroke.

Reducer

Right angle worm gear. 1.25 min. service factor.

Solenoid Valve

120 VAC.

Application

Used to power two belts with each belt powering a maximum of seven diverts. Has the Drive and Power unit included with the Diverter Unit. Take-up unit is included within the Dual Drive Unit on the down stream side.

Powered Belt On Roller (PBR)

Intermediate Section

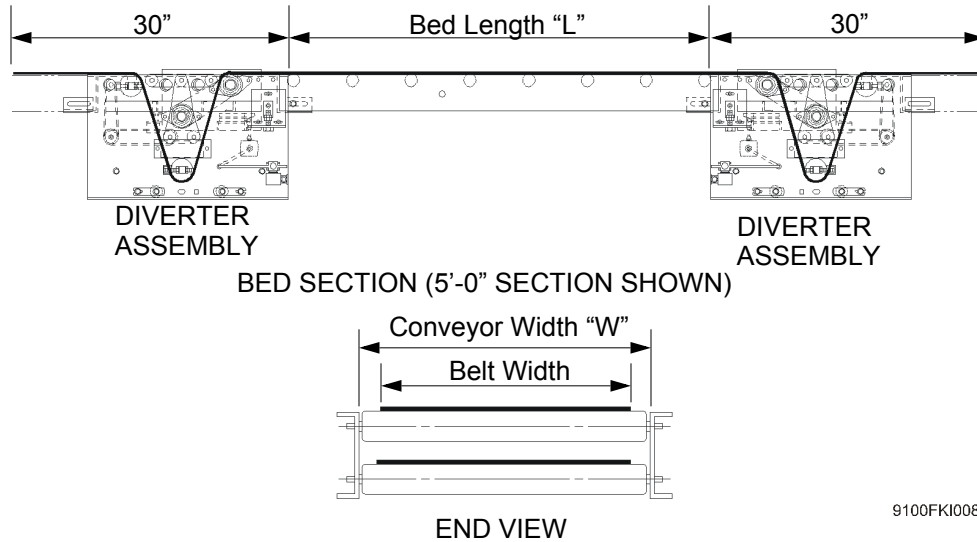

Figure C - 7 Powered Belt On Roller (PBR) - Intermediate Section

Frame

5" deep x 1 1/4" wide x 10 ga. formed channel rails with four (4) spreader members per 10' 0" long section of 15", 21" and 27" "W", and six (6) spreader members per 10' 0" long section of 33" "W". Frame members are powder-coated Gray. All nuts, bolts and washers are plated.

Carrying Rollers

G196GHS with High Speed Grease-packed bearings. Axles are 7/16" hex and rest in hex shaped holes. Rollers are mounted "high" in the frame at 8" centers.

Belt Return Roller

G196GHS with grease-packed bearings. Included with bed section.

Application

Used between Diverters units, End Drive units, Center Drive units, End Take-up units and End Idler units.

End Drive Unit - Series 800

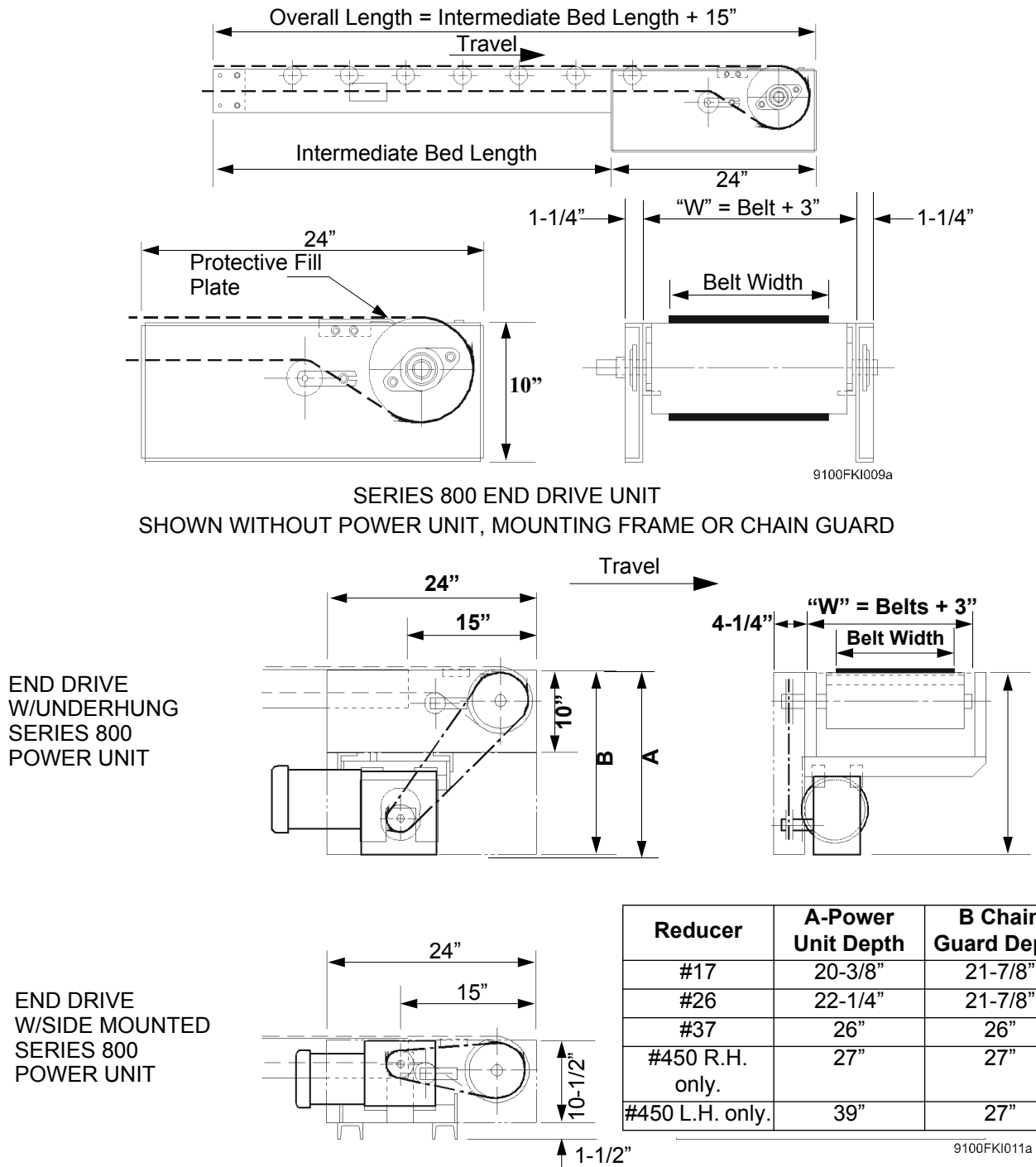

Figure C - 8 Series 800 End Drive Unit Components and Power Unit

Frame

10" deep x 10 ga. formed steel side plates, 24" long, with bolted fill plate and cross members. Powder-coated gray.

Drive Pulley/Shaft

8 5/8" diameter, lagged and edge crowned; keyed to 1 7/16" dia. CRS drive shaft.

Bearings

Grease-packed, precision bearing cartridge with 2 bolt flange-type housing.

Snub Roller

No. 251GHS roller. Adjustable for belt tracking.

Side Guards

5 1/2" and 11" high.

Capacity

570 lbs. effective belt pull.

Power Unit Mounting

Underhung or Side-mounted (see Series 800 - Power Units).

Chain Guard

Removable, fully-enclosed.

Width

15", 21", 27", 33" "W".

Belt Length

Add 6'-5".

Motor

C-Face type totally-enclosed, Fan-Cooled (TEFC), 750 rpm.

Horsepower

1, 1.5, 2, 3, 5 and 7.5 HP

Power Supply

230/460 volts / 3 phase / 60 Hz.

Reducer

C-face, right-angle, worm gear type.

Sprockets

Type "B" w/keyed Hub and 2 set screws; hardened teeth.

Service Factor

Chain drive = 1.40 (min.). Motor = Varies with horsepower. Reducer = 1.25 (min.).

Chain Guard

Removable, fully-enclosed.

Application

Used to drive up to 7 diverts. A Take-up terminal end is required.

Note: An EDU's assembly designation (RH or LH) refers to the side of the conveyor on which the power unit and chain drive is located (as seen when looking in the direction of travel).

An EDU will be factory-mounted to the conveyor's longest Intermediate Bed Section unless requested otherwise.

Used to power PBR Intermediate Section Belt and diverters via PTO in the diverter.

Note: Motor mount adapter required on #450 P.U. dimensions include adapter.

RH = Right Hand Mounted and LH = Left Hand Mounted.

Reducer used depends on horsepower requirement (see Power Unit Chart in Section D).

Center Drive Unit - Series 800

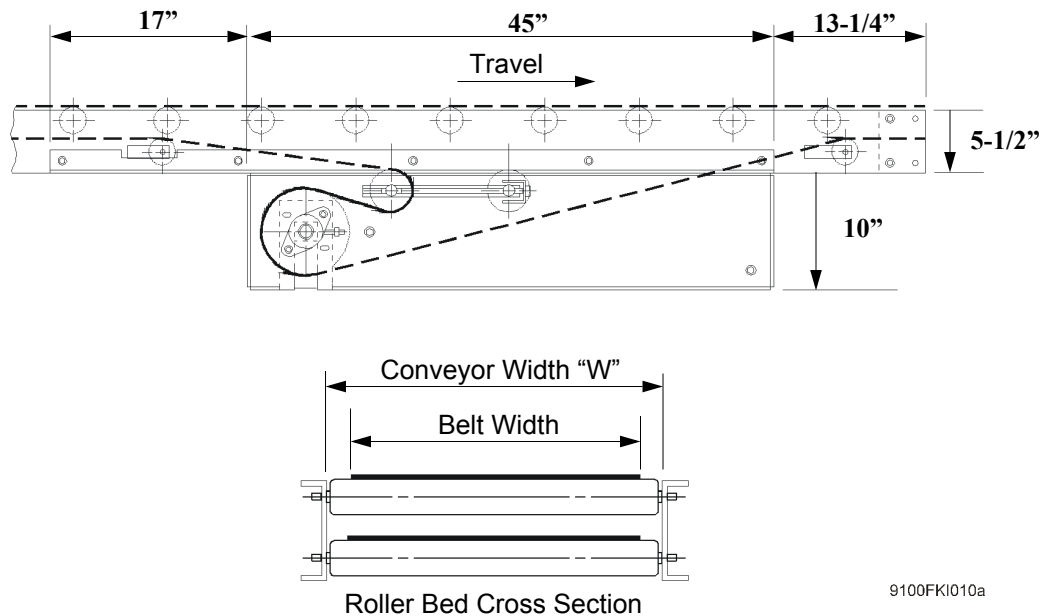

SERIES 800 CENTER DRIVE UNIT
SHOWN WITHOUT POWER UNIT OR CHAIN GUARD

Figure C - 9 Series 800 End Drive Unit Components

Frame

10" deep x 10 ga. formed steel side plates, 45" long, with bolted fill plate and cross members. Powder-coated gray.

Drive Pulley/Shaft

8 5/8" diameter, lagged and edge crowned; keyed to 1 7/16" dia. CRS drive shaft.

Bearings

Grease-packed, precision bearing cartridge with 2 bolt flange-type housing.

Snub Roller

No. 251GHS roller. Adjustable for belt tracking.

Take-Up Roller/Shaft

3 1/2" diameter, edge crowned, with grease-packed, precision bearings and 1 1/8" square axle. Manual screw adjustment provides 10" movement.

Capacity

570 lbs. effective belt pull.

Power Unit Mounting

Underhung only.

Chain Guard

Removable, fully-enclosed.

Width

15", 21", 27", 33" "W".

Belt Length

Double the length of the bed section and add 8'-4".

Take-Up Adjustment Range

6"

Motor

C-Face type totally-enclosed, Fan-Cooled (TEFC), 1750 rpm.

Horsepower

1, 1.5, 2, 3, 5 and 7.5 HP

Power Supply

230/460 volts / 3 phase / 60 Hz.

Reducer

C-face, right-angle, worm gear type.

Sprockets

Type "B" w/keyed Hub and 2 set screws; non-hardened teeth used for speeds less than 180 fpm.

Single taper-lock with hardened teeth used for speeds of 180 fpm or greater.

Service Factor

Chain drive = 1.40 (min.). Motor = Varies with horsepower. Reducer = 1.25 (min.).

Chain Guard

Removable, fully-enclosed.

Application

Used to power PBR Intermediate Section Belt and Diverters via PTO in the diverter.

Note: Motor mount adapter required on #450 P.U. dimensions include adapter.

RH = Right hand Mounted and LH = Left Hand Mounted.

Reducer used depends on horsepower requirement (see Power Unit chart in Section D).

Used to drive up to 7 diverts. Idler type terminal ends required.

Note: A CDU's assembly designation (RH or LH) refers to the side of the conveyor (horizontal) on which the power unit and chain drive are located (as seen when looking in the direction of travel).

A CDU will be factory-mounted to the conveyor's longest Intermediate Bed Section unless requested otherwise.

End Take-Up Unit- Series 800

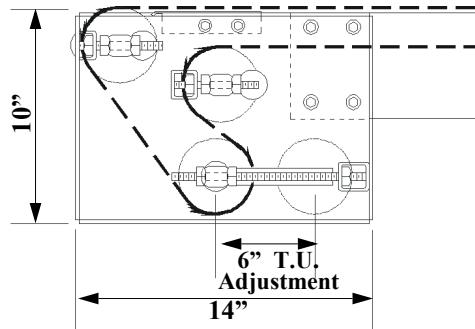

9100FKI013a

Figure C - 10 End Take-Up Unit

Frame

10" deep x 10 ga. formed steel side plates, 14" long, with bolted cross-members. Powder-coated gray.

Take-Up Roller/Shaft

3 1/2" diameter, edge crowned with 1 1/8" square axle. Manual, screw-type take-up provides 6" of pulley movement.

Snub Roller

3 1/2" diameter, edge crowned with 1/8" square axle.

Idler Roller

3 1/2" diameter, edge crowned with 1 1/8" square axle. 1" cross member for belt tracking.

Width

15", 21", 27", 33" "W".

Belt Length

Add 3'-0".

Application

Used on end of Powered Belt on Roller (PBR) section with End Drive units to adjust belt take-up and align idler rollers for obtaining correct belt tracking.

End Idler Unit - Series 800

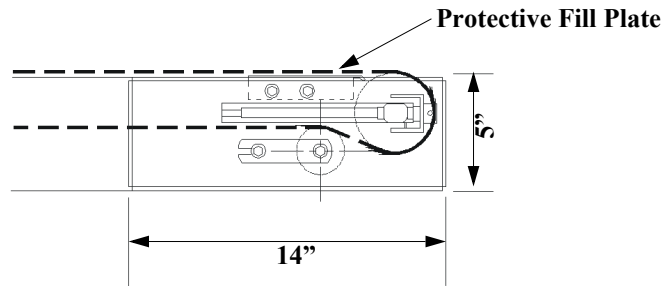

9100FK1068a

Figure C - 11 End Idler Unit

Frame

5" deep x 10 ga. formed steel side plates, 14" long with bolted fill plate and cross members. Power-coated gray.

Take-Up Roller/Shaft

3 1/2" diameter, edge crowned with 1 1/8" square axle. Manual, screw-type take-up provides 6" of pulley movement.

Snub Roller

No. 251GHS roller. Self-aligning for belt tracking.

Width

15", 21", 27", 33" "W"

Belt length

Add 2'-0"

Application

Used on end of Powered Belt on Roller (PBR) section with Center Drive units to adjust belt take-up and align idler rollers for obtaining correct belt tracking.

Return Belt Support Roller Bracket

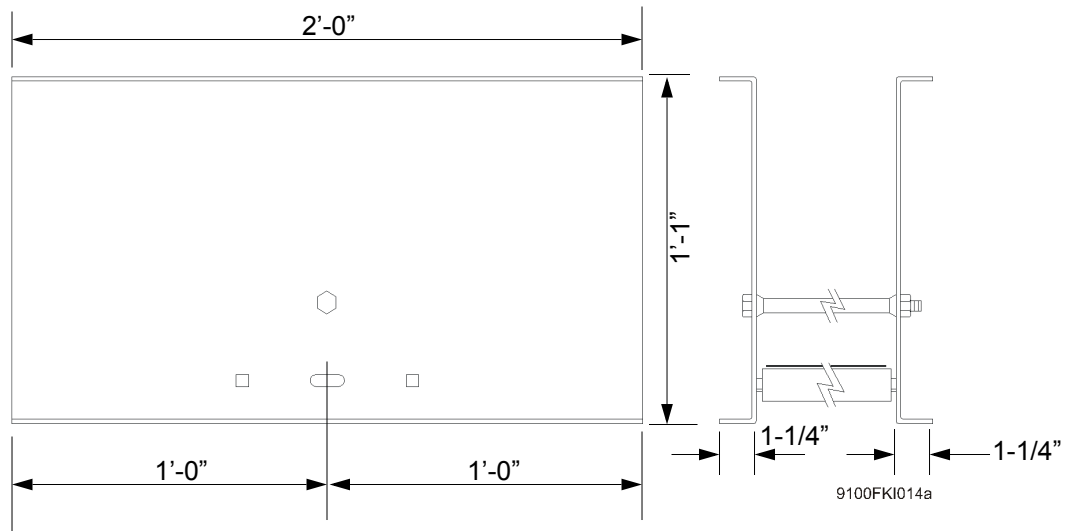

Figure C - 12 Return Roller Bracket

Frame

13" deep x 10 ga. formed steel 24" long. Powder-coated gray.

Support Roller

No. G196G high speed roller. Field installed.

Application

Required to support Return Belt when there is more than 10' between Diverter Units. Fastened to Main Line Belt Intermediate Section.

Note: Spreader shipped loose. Support roller shipped in bed section ordered to mount in plate with adjoining bracket.

SECTION D: ENGINEERING DATA

System Application Guidelines and Formulas

Sortable Items

Items to be sorted on the UniSort IV should have a firm, flat continuous bottom surface allowing good frictional contact with the two rows of diverter wheels.

Items having protrusions that could cause damage to the sorter belting or get caught in the diverter mechanism or on guard rails should not be handled on the UniSort IV.

Item Size, Shape, Weight

Size Range

9" to 40" Long

6" to 30" Wide

2" Minimum Height

Weight

2 lbs. to 75 lbs.

When items for sorting are less than 16" long (i.e. less than twice the center dimension of the supporting rollers), it may be necessary to determine if any possible bobbing action would be objectionable or might affect the reliable diverting of those items.

Items that are top heavy and/or whose height is greater than 1.5 times the width may experience undesirable angular rotation during diverting. Those items should be oriented to reduce any rotation. For example, a top-heavy item should be laid down on the sorter belt.

Product Alignment

Items for sorting must be aligned to the divert side before product reaches the sorter's infeed end.

Gap Between Product

An eighteen inch (18") minimum gap must be maintained between product to ensure reliable diverting. The gap between product must also be taken into account when calculating UniSort Iv Belt Speed. Product gapping and product alignment must be performed before product is inducted onto the UniSort IV.

Divert Side

The UniSort IV is a single sided sorter. Product diverting can be either to the right side or to the left side as viewed toward the discharge end of the UniSort IV.

Divert Angle

The two rows of pop-up wheels are skewed to effect a fixed 45 degree divert angle.

Product Diverting

The pop-up wheels must be in full up position before the leading edge of the product reaches the diverter assembly.

Unreliable product diverting or product jams may occur if the diverter wheels are popped up or down while product is in contact with the diverter wheels.

During the actual diverting of product is guided towards the inside of the take-away conveyor.

Note: This assumes that the take-away conveyor is applied and installed as specified.

Transition Points

Fill Roller(s) may be required to ensure a smooth transference of product onto the UniSort IV at the infeed end or, if used, from the discharge end.

CAUTION: Pop-out safety type fill rollers must be used to eliminate the possibility of personal injury due to pinch points. A pop-out roller should be applied so that no personal injury would result if it becomes dislodged.

Inclined Operation

The UniSort IV diverter Assemblies should not be inclined. the powered belt on roller (PBR) Intermediate Sections should also be kept level to ensure proper tracking of product.

Take-Away Conveyors (After Sort Conveyors)

For a UniSort IV Belt Speed of 150 fpm, a powered roller type conveyor should be used for reliable conveying of diverted product. The powered roller conveyor required operating speed is calculated by:

$$\text{Take - Away Conveyor Speed} = \frac{\text{UniSort IV Belt Speed}}{0.707}$$

For UniSort IV Belt Speed of 180 fpm and greater, a gravity skate wheel type conveyor may be used as a take-away conveyor. Gravity roller types should not be used as a take-away conveyor due to the inherent speed retarding action of the gravity rollers.

The gravity take-away conveyor may be either the recommended 45 degree straight GWJ (gravity wheel junction) type or a 90 degree spur curve type.

The width ("W") of the 45 degree straight GWJ type take-away conveyor should be equal to the UniSort IV Intermediate Section width ("W").

The width ("W") of a 90 degree Spur Curve type take-away should be one width size (6") greater than the UniSort IV Powered Belt on Roller (PBR) Intermediate Section width. For example, if the selected Unisort IV Intermediate Section width is 21" "W", then a 90 degree spur Curve type take away should have a width of 2" "W", see Table D-1.

Table D - 1 UniSort IV Take-Away Conveyors

Take-Away Conveyor Type	Application Criteria	Comments								
45 degree Straight Gravity Wheel Junction.	<ol style="list-style-type: none"> Used as take-away when UniSort IV Belt speeds are greater or equal to 180 fpm. Not recommended when UniSort IV belt speed is less than 180 fpm. Width ("W") specified equal to UniSort IV PBR Intermediate Section width ("W"). 	<ol style="list-style-type: none"> Specify for right hand or left hand diverting. Install with 5/8 inch per foot pitch. No field modifications required for fastening to UniSort IV Diverter. 								
45 degree Straight Powered Roller Diverting Type Junction.	<ol style="list-style-type: none"> Recommended as take-away conveyor type when UniSort IV belt speed is less than 180 fpm. May be used as alternative Take-away for UniSort IV Belt speed of 180 fpm and/or for better conveying of light weight product (2-5 lbs.). Width ("W") specified equal to UniSort IV PBR Section width ("W"). 	<ol style="list-style-type: none"> Take-away speed = $\frac{\text{UniSort IV Belt Speed}}{0.707}$ Select and specify to meet live load requirements. Cannot be PTO driven from UniSort IV - must include own Drive / Power unit. 								
90 degree Spur Curve-Gravity Wheel Type.	<ol style="list-style-type: none"> May be selected to meet layout requirements instead of 45 straight gravity wheel type. Used for UniSort IV Belt speed greater or equal to 180 fpm. Width ("W") specified one size greater than UniSort IV PBR Intermediate Section width ("W"). 	<ol style="list-style-type: none"> Specify Dense wheel Pattern with heavy duty (steel) wheels. Width ("W") Inside Radius <table style="margin-left: 40px;"> <tr> <td>15"</td> <td>2'-6"</td> </tr> <tr> <td>21"</td> <td>3'-4"</td> </tr> <tr> <td>27"</td> <td>4'-0"</td> </tr> <tr> <td>33"</td> <td>5'-0"</td> </tr> </table> 	15"	2'-6"	21"	3'-4"	27"	4'-0"	33"	5'-0"
15"	2'-6"									
21"	3'-4"									
27"	4'-0"									
33"	5'-0"									
90 degree Spur Curve-Powered Roller - True Taper Rollers.	<ol style="list-style-type: none"> May be selected to meet layout requirements instead of 45 straight powered roller type. Used for UniSort IV Belt speed less than or equal to 180 fpm. Width ("W") specified one size greater than UniSort IV PBR Intermediate Section width ("W"). 	<ol style="list-style-type: none"> Take-away speed = $\frac{\text{UniSort IV Belt Speed}}{0.707}$ Select and specify to meet live load requirements. Cannot be PTO driven from UniSort IV - must include own Drive / Power unit. Width ("W") Inside Radius <table style="margin-left: 40px;"> <tr> <td>15"</td> <td>2'-6"</td> </tr> <tr> <td>21"</td> <td>3'-4"</td> </tr> <tr> <td>27"</td> <td>4'-0"</td> </tr> <tr> <td>33"</td> <td>5'-0"</td> </tr> </table> 	15"	2'-6"	21"	3'-4"	27"	4'-0"	33"	5'-0"
15"	2'-6"									
21"	3'-4"									
27"	4'-0"									
33"	5'-0"									

Floor Supports

Two types of 2500 lb. capacity floor supports are used for supporting a UniSort IV. Type FSM is used for supporting diverter units and type FSMU4 is used for the powered belt on roller (PBR) Intermediate Sections. The FSMU4 floor support provides required clearance for the return run of the powered belt.

The Diverter Units should have a type FSM floor support located at each corner. (Two floor supports per diverter).

The powered belt on roller (PBR) Intermediate Sections should have a type FSMU4 floor support located at any PBR Intermediate Section splice joint or for any continuous Intermediate Section length greater than ten feet (10').

Ceiling Hangers

Type CHA ceiling hangers are used for suspending the powered belt or roller (PBR) Intermediate Sections.

The Unisort IV Diverter Units, however, may require an application engineered ceiling hanger in order to provide clearance for the take-away conveyor. Consult factory for any required application assistance.

Return Belt Support

The Return Belt Support Bracket with a 1.9" high speed roller is used to support the return belt whenever Divert Centers are ten feet (10') or more apart.

Return Belt Angle

The return belt, as it travels from a diverter unit to the underside of an Intermediate Section, should be at a 45 degree or less return angle.

The return belt angle is determined by intermediate section lengths and placement of the return belt snub roller in the Intermediate Section. This can be accomplished by having dimension A always greater than dimension B as shown in the Figure D - 2.

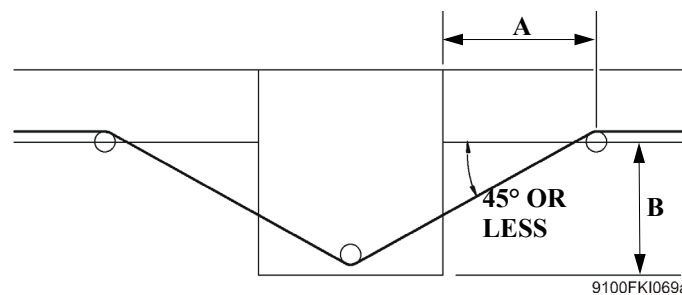

Figure D - 2 Return Belt Angle

Product Containment Guarding

In order to prevent product from being accidentally discharged off the UniSort IV, the type F; 5-1/2" high and the type G; 11" high closed type guarding is available.

When applying product containment guarding, attention must be paid to ensure that the guarding will not interfere with either the smooth movement nor the diverting and taking-away of product.

Personnel Safety Guarding

Personnel safety guarding is to be applied for preventing possible personal injury to any person coming into accidental contact with any moving part of the UniSort IV. See Figure D - 3.

These areas include the following:

1. Pinch Points.
2. Diverter Unit-top and bottom surfaces.
3. Exposed sections of the carrying belt return run including edge and bottom surfaces.

Exception to the above can be taken when any moving UniSort IV part is in fact guarded by location. (Ref: ANSI B20.1 - 1987).

The UniSort IV Power Units are supplied with guards that fully enclose the drive chain and sprockets.

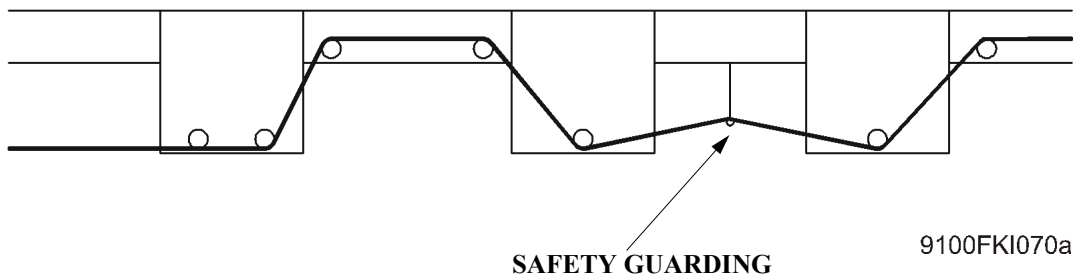

Figure D - 3 Safety Guarding

Application Formulas

Determining Sortation Rate - Cartons Per Minute (CPM)

Sortation rate are frequently calculated in terms of SUSTAINED RATE CPM and MAXIMUM MACHINE RATE CPM. Using this calculated maximum machine rate CPM provides compensation for possible unforeseen or non-calculable system performance variables.

$$\text{Sustained CPM} = \frac{\text{Number of Cartons/Day}}{\text{No of Shifts/Day}} = \frac{\text{Number of Cartons/Shift}}{\text{No of Hours/Shift}} = \frac{\text{Number of Cartons/Hour}}{60 \text{ Minutes/Hour}}$$

Example: Desired Rate = 40,000 Carton/Day sustained.

No. of Shifts/Day = 2

No. Hours/Shift = 7.5

Calculate rate in cartons per minute.

$$\text{Sustained CPM} = \frac{40,000}{2} = \frac{20,000}{7.5} = \frac{2666.7}{60} = 44 \text{ Cartons/Minute}$$

Maximum Machine Sort Rate = Sustained Rate x 1.25

Example: Sustained Rate = 44 CPM (from above example)

Maximum Machine Rate = 44 x 1.25 = 55 CPM.

Determining Sorter Belt Speed - Feet Per Minute (FPM)

The following formula allows calculating the speed the UniSort IV belt must run to achieve the calculated MAXIMUM MACHINE SORTATION RATE.

The following formula also assumes an 18" gap between cartons and a continuously running (non-indexing) brake-metering belt for achieving the 18" minimum gap between cartons.

$$\text{FPM} = \left(\frac{\text{Min Carton Length} + \text{Min Gap}}{\text{Min Carton Length}} \right) (\text{Max Machine Rate}) \left(\frac{\text{Avg Cartons Length}}{12 \text{ in/ft}} \right)$$

Example: Minimum Carton Length = 12"

Average Carton length = 20"

Minimum Gap = 18"

Maximum Machine Rate = 55 CPM

$$\text{FPM} = \frac{(12" + 18")}{12"} (55 \text{ CPM}) \frac{(20")}{12"} = (2.5) (55) (1.67) = 230 \text{ FPM}$$

Determining Live Load (Lbs. Per Foot)

$$\text{Live Load} = \frac{\text{Average Carton Weight} \times \text{Maximum Machine Sort Rate}}{\text{UniSort IV Belt Speed}}$$

Example: AVE. Carton Weight = 45 lbs./carton

Maximum Sort Rate = 55 CPM

UniSort IV Belt Speed = 230 fpm

$$\text{Live Load} = \frac{45 \text{ lbs/carton} \times 55 \text{ CPM}}{230 \text{ FPM}} = 10.76 \text{ lbs/ft} = 11 \text{ lbs/ft Max}$$

Note: Heaviest carton for sorting on UniSort IV should not exceed 75 lbs.

Determining The Number of UniSort IV Drives

More than one UniSort IV drive will be required if:

1. The required number of UniSort IV Diverters exceed 7 when using a Single, End or Center type drive or . . .
2. The number of diverters exceed 14 when using a Dual Drive and/or . . .
3. The calculated pull exceeds 570 lbs. for Single, End or Center Drive, or 1140 lbs. for Dual Drive.

Note: The single and Dual Drive Units have built in diverters. **Do not include** this diverter in performing these calculations.

$$\text{Number of Drives} = \frac{\text{Total Number of Diverter (Sorts)}}{\text{Maximum Number of Diverters Per Drive}}$$

Example: Number of Diverters (sorts) = 19
Maximum Number of Diverts per Drive = 7

$$\text{Number of Drives} = \frac{19}{7} = 2.7 = 3 \text{ Drive Units Required}$$

Layout for this could include using the Dual Drive with Diverter for powering 12 diverters and an 800 Series End drive for the remainin 6 diverters. Refer to Section E - Layout Dimensions as a reference.

Note: It is recommended that the number of diverts per drive unit be balanced as close as possible.

Calculating Effective Belt Pull

Effective Belt Pull must be calculated for each drive unit (i.e. drive belt) used in the UniSort IV Sorter. Note that the Dual Drive Unit drives two separate belts which means that the following calculations must be done for each belt. The Single, End and Center type drive units power only one belt.

Effective Belt Pull - for even spacing between divert points

A Unisort IV is classified as having even spacing between divert points if there is 30% or less variation in distance between any two divert points.

The following Short Form formulas is used for calculating the effective belt pull when there is even spacing between divert points.

$$P = A \times Pe \times L + B (Pd)$$

P= Total Effective Pull

Pe=Intermediate Section Pull (see Table D-3).

Pd=Diverter Unit Pull (see Table D-4).

A= See Table D-2.

B= See Table D-2

L= total Length (ft.) of Sorter per drive belt.

Example: 800 Series End Drive Unit

Number of Diverters = 6

Length (including Drive & Term end) = 49.7 ft.

Width = 27" "W").

Maximum Carton Weight 45 lbs.

Live Load = 10 lbs./ft.

A = 1.58 (from Table D-2)

B = 10.06 (from Table D-2)

Pe = 1.2 (from Table D-3)

Pd = 32.38 (from Table D-4)

$$P = 1.58 \times 1.2 \times 49.7 + 10.06 \times 32.38 = 420 \text{ lb. Pull}$$

Refer to the Selecting the Power Unit Drive topic in this section.

Table D - 2

Number of Sorts	A	B
1	1.08	1.15
2	1.16	2.47
3	1.25	3.99
4	1.35	5.74
5	1.46	7.75
6	1.58	10.06
7	1.72	12.72

Table D - 3 Intermediate Pull - "Pe" (lbs./ft.)

Live Load (lbs./ft.)	Conveyor Width			
	15"	21"	27"	33"
5	0.6	0.7	0.9	1.0
10	0.9	1.0	1.2	1.3
15	1.2	1.3	1.5	1.6
20	1.5	1.6	1.8	1.9
25	1.8	1.9	2.1	2.2
30	2.1	2.2	2.4	2.5
35	2.4	2.5	2.7	2.8

Table D - 4 Diverter Unit Pull - "Pd"

Average Carton Weight (Pounds)	Conveyor Width			
	15"	21"	27"	33"
5	16.38	22.38	29.38	35.38
10	16.75	22.75	29.75	35.75
15	17.13	23.13	30.13	36.13
20	17.50	23.50	30.50	36.50
25	17.88	23.88	30.88	36.88
30	18.25	24.25	31.25	37.25
35	18.63	24.63	31.63	37.63
40	19.00	25.00	32.00	38.00
45	19.38	25.38	32.38	38.38
50	19.75	25.75	32.75	38.75
55	20.13	26.13	33.13	39.13
60	20.50	26.50	33.50	39.50
65	20.88	26.88	33.88	39.88
70	21.25	27.25	34.25	40.25
75	21.63	27.63	34.63	40.63

Effective Belt Pull - for un-even spacing between divert points

A Unisort IV is classified as having un-even spacing between divert points if there is more than a 30% variation in distance between any two divert points.

the following formulas are used for calculating the Effective Belt Pull when there is un-even spacing between divert points.

P= Effective Belt Pull

Pe=Intermediate Section Pull (see Table D-3).

Pd=Diverter Unit Pull (see Table D-4).

L= total Length (ft.) of Sorter per drive belt. Will include diverter unit length, intermediate section length, and applicable terminal end length. (See the following illustration).

Instructions for using the “Long Form” Effective Belt Pull formulas.

1. Verify the need to use this formula rather than the “Short Form” on the previous page.
2. Determine individual diverter section length by referring to the appropriate diagram (fill in Part #1, Page D-11).
3. Determine the value of Pe (Table D-4).
4. Multiply the Pe value times each diverter section length as shown in Part #2, Page D-11).
5. Perform the steps in Part #3 based on the Number of Diverts - Effective Pull Calculating shown in Table D-5.

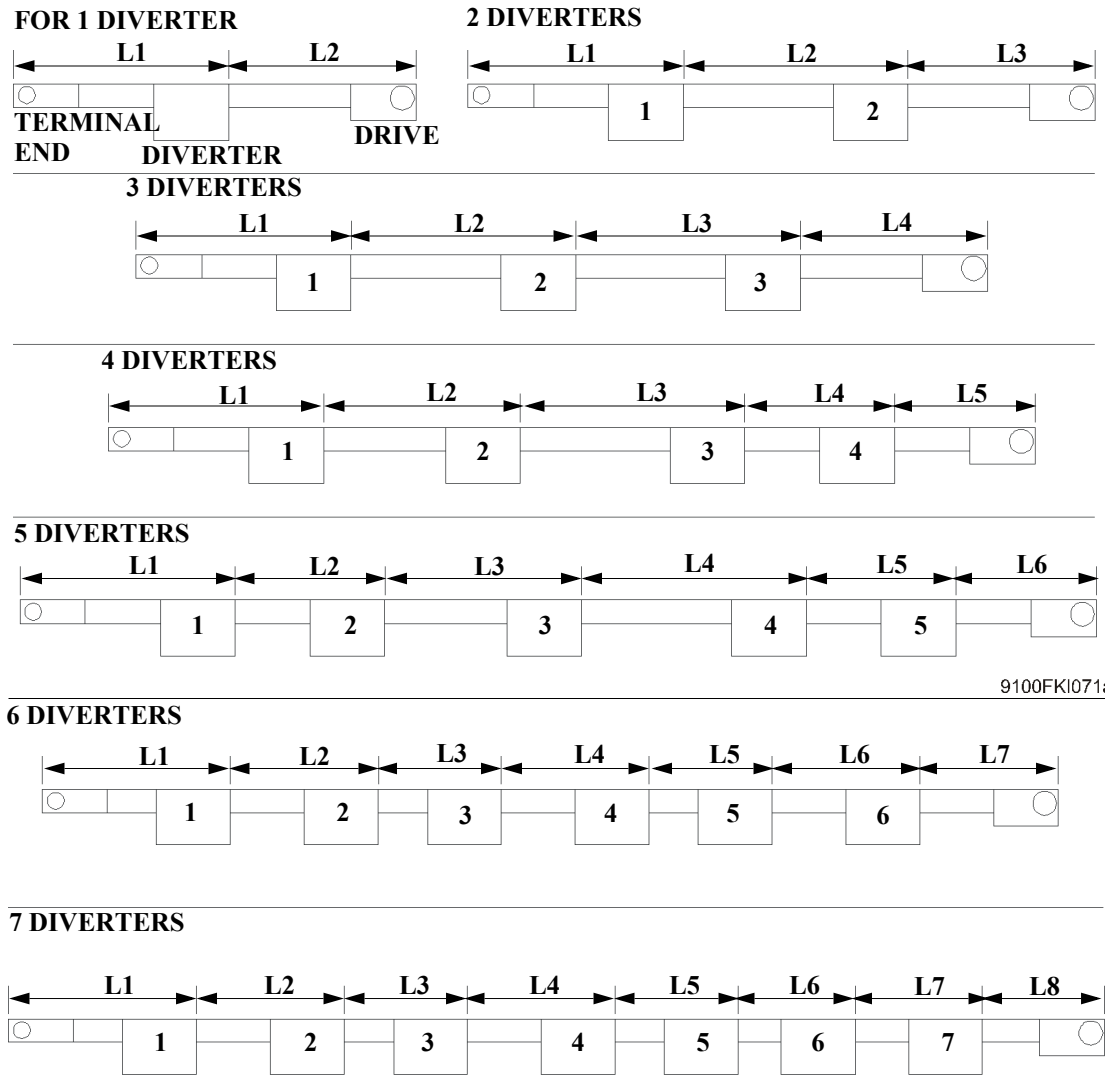

9100FKI071a

9100FKI072a

Figure D - 5

Part 1

L1 = ____ L2 = ____ L3 = ____ L4 = ____ L5 = ____ L6 = ____ L7 = ____ L8 = ____
 Pe = ____ Pd = ____

Part 2

Pe x L1 = ____ Pe x L2 = ____ Pe x L3 = ____ Pe x L4 = ____
 Pe x L5 = ____ Pe x L6 = ____ Pe x L7 = ____ Pe x L8 = ____

Part 3

- | | | | |
|-------------------------------|---------|-------------------------------|---------|
| 1. Pe x L1 = | _____ | 16. Multiply Line 15 x 1.15 = | _____ |
| 2. Pd = | + _____ | 17. Pe x L5 = | + _____ |
| 3. Add Line 1 + 2 = | _____ | 18. Pd = | + _____ |
| | x 1.15 | 19. Add Lines 16 + 17 + 18 = | _____ |
| | | | x 1.15 |
| 4. Multiply Line 3 x 1.15 = | _____ | 20. Multiply Line 19 x 1.15 = | _____ |
| 5. Pe x L2 = | + _____ | 21. Pe x L6 = | + _____ |
| 6. Pd = | + _____ | 22. Pd = | + _____ |
| 7. Add Lines 4 + 5 + 6 = | _____ | 23. Add Lines 20 + 21 + 22 = | _____ |
| | x 1.15 | | x 1.15 |
| 8. Multiply Line 7 x 1.15 = | _____ | 24. Multiply Line 23 x 1.15 = | _____ |
| 9. Pe x L3 = | + _____ | 25. Pe x L7 = | + _____ |
| 10. Pd = | + _____ | 26. Pd = | + _____ |
| 11. Add Lines 8 + 9 + 10 = | _____ | 27. Add Lines 24 + 25 + 26 = | _____ |
| | x 1.15 | | x 1.15 |
| 12. Multiply Line 11 x 1.15 = | _____ | 28. Multiply Line 27 x 1.15 = | _____ |
| 13. Pe x L4 = | + _____ | 29. Pe x L8 = | + _____ |
| 14. Pd = | + _____ | 30. Pd = | + _____ |
| 15. Add Lines 12 + 13 + 14 = | _____ | | |

No. of Diverts	Effective Pull Calculating (P)
One	Perform Steps (1) through (5) P = Step (5) + Step (4)
Two	Perform Steps (1) through (9) P = Step (9) + Step (8)
Three	Perform Steps (1) through (13) P = Step (13) + Step (12)
Four	Perform Steps (1) through (17) P = Step (17) + Step (16)
Five	Perform Steps (1) through (21) P = Step (21) + Step (20)
Six	Perform Steps (1) through (25) P = Step (25) + Step (24)
Seven	Perform Steps (1) through (30) P = Step (30) + Step (29)

Refer to the Selecting the Power Unit Drive topic in this section.

Selecting the Power Unit Drive

Table D - 5 800 Series Drives-End and Center Types Application (570 lb. Pull Maximum)

Horsepower	Conveyor Belt Speed (FPM)				
	150	180	220	250	300
	Maximum Belt Pull				
1.0	158	132	108	99	84
1.5	237	198	161	149	125
2.0	301	264	214	205	172
3.0	466	395	320	295	248
5.0	570	570	539	498	419
7.5	NA	NA	570	570	570

Table D - 6 Single Drive-Application (570 lb. Pull Maximum)

Horsepower	Conveyor Belt Speed (FPM)				
	150	180	220	250	300
	Maximum Belt Pull				
1.0	158	132	108	99	84
1.5	237	198	161	149	125
2.0	301	264	214	205	172
3.0	466	495	320	295	248
5.0	570	570	539	498	419
7.5	NA	NA	570	570	570

Table D - 7 Dual Drive Application (1140 lb. Pull Maximum)

Horsepower	Conveyor Belt Speed (FPM)				
	150	180	220	250	300
	Maximum Belt Pull				
1.0	301	265	214	205	172
1.5	466	395	320	295	248
2.0	779	665	539	498	419
3.0	1140	1033	826	750	631
5.0	NA	1140	1039	1025	855
7.5	NA	NA	1140	1140	1140

Sortation Rate

Uniform	Main Sort Line Speed - FPM				
	150	180	220	250	300
	Delivery Rate - Cases/Minute				
9	66	80	97	111	133
12	60	72	88	100	120
16	53	63	77	88	106
20	47	56	70	78	94
24	42	51	62	71	85
30	37	45	55	62	75
36	33	40	48	55	66
40	31	37	45	51	62

Note: The above rates are based on constant 18" gap between cases and all cases being the same length. Actual rates will depend on case length mix, induction system thru-put and availability of product at induct station.

SECTION E: LAYOUT DIMENSIONS

See Section C for specific component layout dimensions.

Basic Configurations

The following configurations will give examples on configuring a UniSort IV Sorter using the different types of diverters and drive units:

- 800 Series End Drive - End and Intermediate Type Diverter
- 800 Series Center Drive and Dual Snub type Diverter
- Single Drive w/Diverter
- Dual Drive w/Diverter
- Take-Up/Idler Interface w/Diverter

800 Series End Drive - End and Intermediate Type Diverter

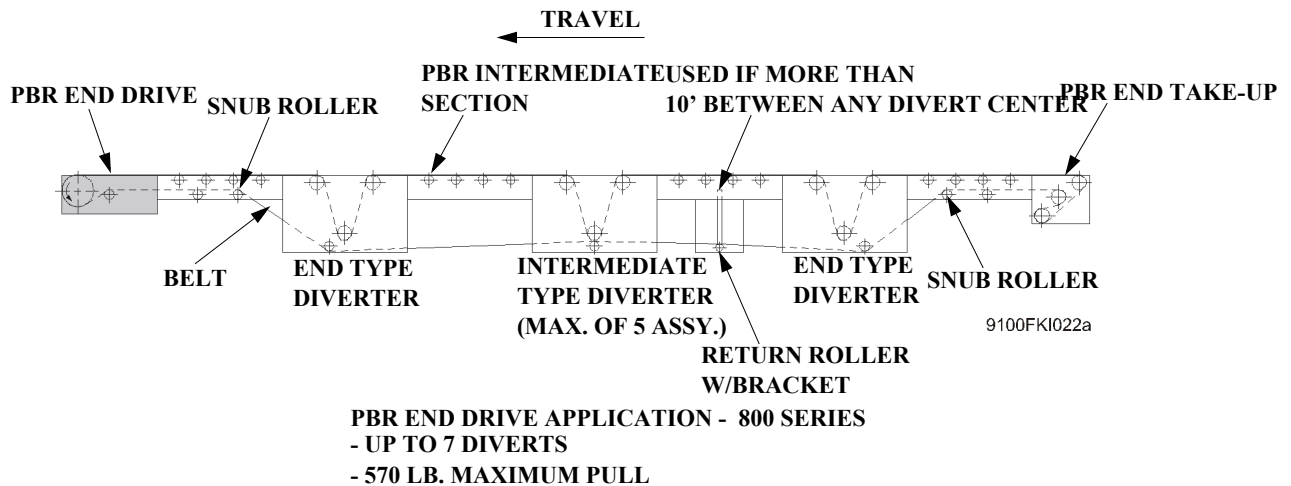

Figure E - 1 End and Intermediate Type Diverter

Figure E - 1 shows an 800 Series End Drive for driving up to 7 diverters with a maximum pull of 570 lbs. the diverters consist of End Types and Intermediate Types. Up to five Intermediate Types can be used as long as the 570 lb. maximum pull limit is not exceeded.

Dimensions

Table E - 1 End and Intermediate Type Diverter Dimensions

Assembly Name	Width	Length	Depth
End Diverter	18", 24", 30", 36"	30"	18 1/8"
Intermediate Diverter	18", 24", 30", 36"	30"	18 1/8"
PBR End Drive	15", 21", 27", 33"	30"	26" - 31"
PBR End Take-Up Section	15", 21", 27", 33"	24"	10"
PBR Intermediate Section	15", 21", 27", 33"	*	5"

*Intermediate section recommended minimum length is 2 times width dimension. PBR End Drive depth depends on power unit horsepower.

800 Series Center Drive and Dual Snub Type Diverter

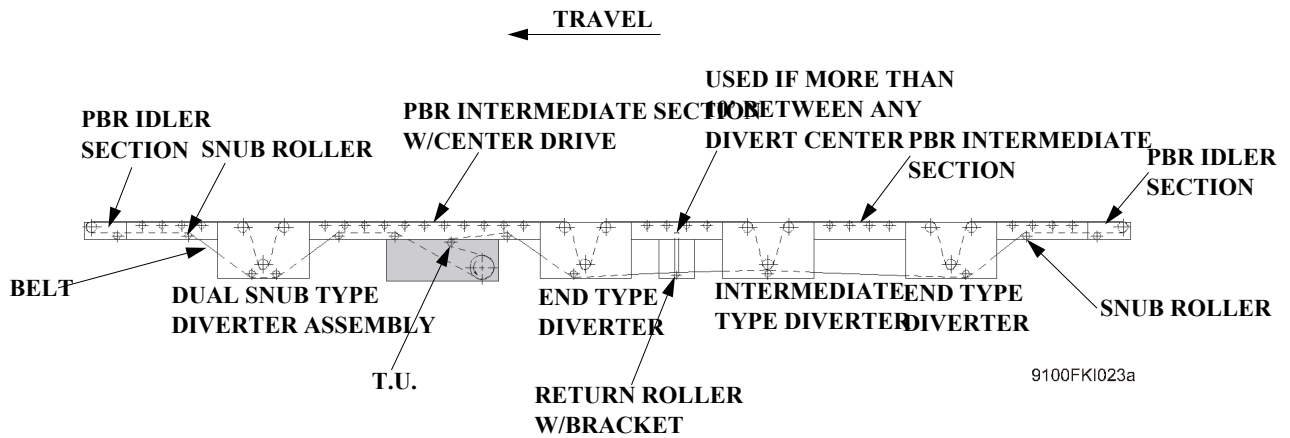

CENTER DRIVE AND DUAL SNUB DIVERTER APPLICATION - 800 SERIES

- UP TO 7 DIVERTS
- 570 LB. MAXIMUM PULL
- DUAL SNUB ASSEMBLY CONTAINS DIVERTER

Figure E - 2 Center Drive and Dual Snub Type Diverter

Figure E - 2 shows an 800 Series Center Drive and Dual Snub diverter for driving up to 7 diverters with a maximum pull of 570 lbs. The center drive can be used instead of an end drive to meet layout requirements. Since the center drive has a built in take-up, the PBR Idler sections are used as terminal ends.

Dimensions

Table E - 2 Center Drive and Dual Snub Type Diverter Dimensions

Assembly Name	Width	Length	Depth
End Diverter	18", 24", 30", 36"	30"	18 1/8"
Intermediate Diverter	18", 24", 30", 36"	30"	18 1/8"
Dual Snub Diverter	18", 24", 30", 36"	30"	18 1/8"
PBR Center Drive	15", 21", 27", 33"	30"	26" - 31"
PBR Idler Section	15", 21", 27", 33"	24"	10"
PBR Intermediate Section	15", 21", 27", 33"	*	5"

*Intermediate section recommended minimum length is 2 times width dimension.

Single Drive w/Diverter

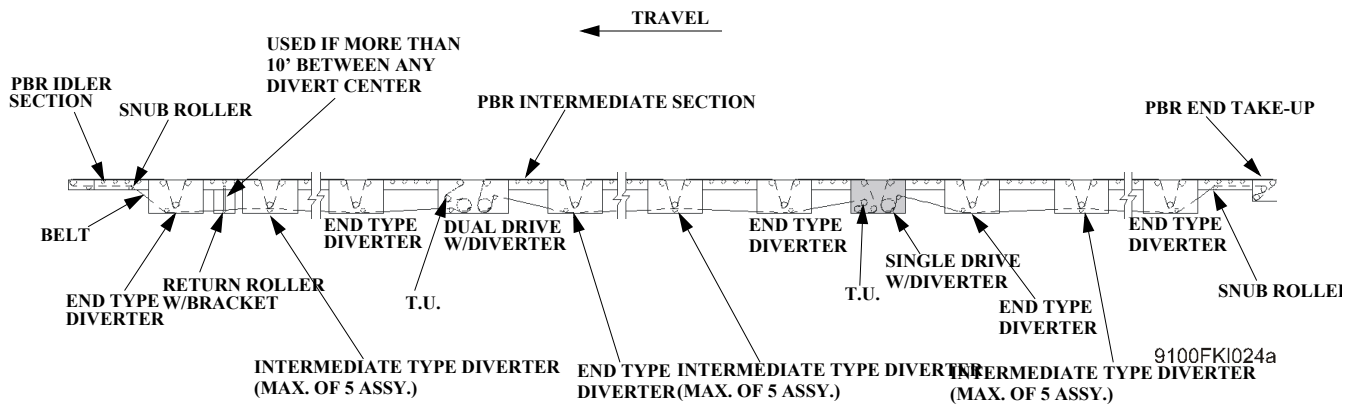

SINGLE DRIVE W/DIVERTER ASSEMBLY APPLICATION
 - UP TO 7 DIVERTS PER SINGLE DRIVE
 - 570 LB. MAXIMUM PULL PER SINGLE DRIVE
 - CONTAINS OWN DIVERTER SECTION

Figure E - 3 Single Drive w/Diverter

Figure E - 3 shows the Single Drive with diverter for driving up to 7 upstream diverters with a maximum pull of 570 lbs. With the included diverter, up to 8 diverters can be powered. The Take-Up included in the single drive is for the separately powered downstream belt.

Dimensions

Table E - 3 Single Drive w/Diverter Dimensions

Assembly Name	Width	Length	Depth
End Diverter	18", 24", 30", 36"	30"	18 1/8"
Intermediate Diverter	18", 24", 30", 36"	30"	18 1/8"
Single Drive w/Diverter	18", 24", 30", 36"	30"	18 1/8"
PBR End Idler Section	15", 21", 27", 33"	14"	20 1/8"
PBR End Take-Up Section	15", 21", 27", 33"	24"	10"
PBR Intermediate Section	15", 21", 27", 33"	*	5"

*Intermediate section recommended minimum length is 2 times width dimension.

Dual Drive w/Diverter

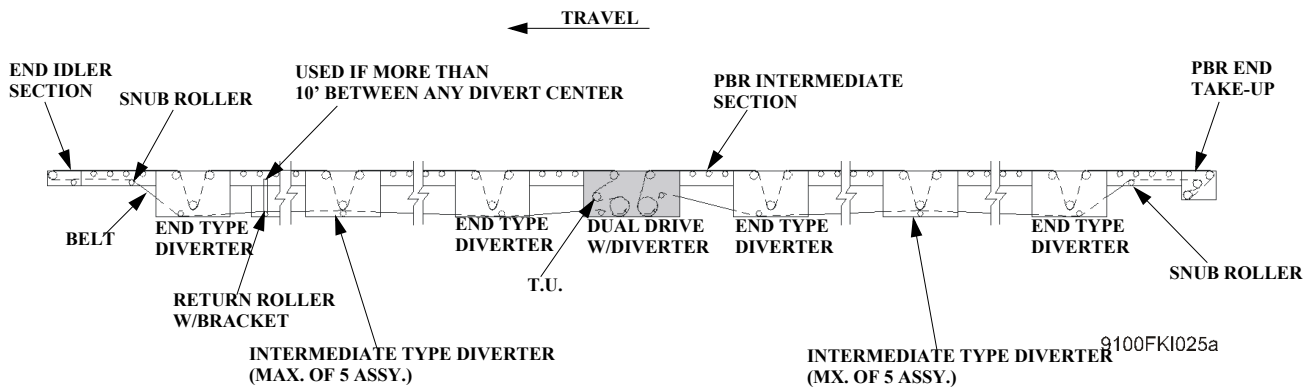

- DUAL DRIVE APPLICATION**
- UP TO 7 DIVERTS PER DRIVE - 14 W/DUAL DRIVE
 - 570 LB. MAXIMUM PUL PER DRIVE - 1140 LB. W/DUAL DRIVE
 - CONTAINS OWN DIVERTER SECTION

Figure E - 4 Dual Drive w/Diverter

Figure E - 4 shows the Dual Drive with diverter can power 7 upstream and 7 downstream diverters with a maximum pull of 570 lb per belt. With the included diverter, up to 15 diverters can be powered. The upstream terminal end must be or include a Take-Up while the downstream terminal end must include an Idler.

Dimensions

Table E - 4 Dual Drive w/Diverter Dimensions

Assembly Name	Width	Length	Depth
End Diverter	18", 24", 30", 36"	30"	18 1/8"
Intermediate Diverter	18", 24", 30", 36"	30"	18 1/8"
Dual Drive w/Diverter	18", 24", 30", 36"	40"	20 1/8"
PBR End Idler Section	15", 21", 27", 33"	14"	5"
PBR End Take-Up Section	15", 21", 27", 33"	14"	10"
PBR Intermediate Section	15", 21", 27", 33"	*	5"

* Intermediate section recommended minimum length is 2 times width dimension.

Take-Up/Idler Interface

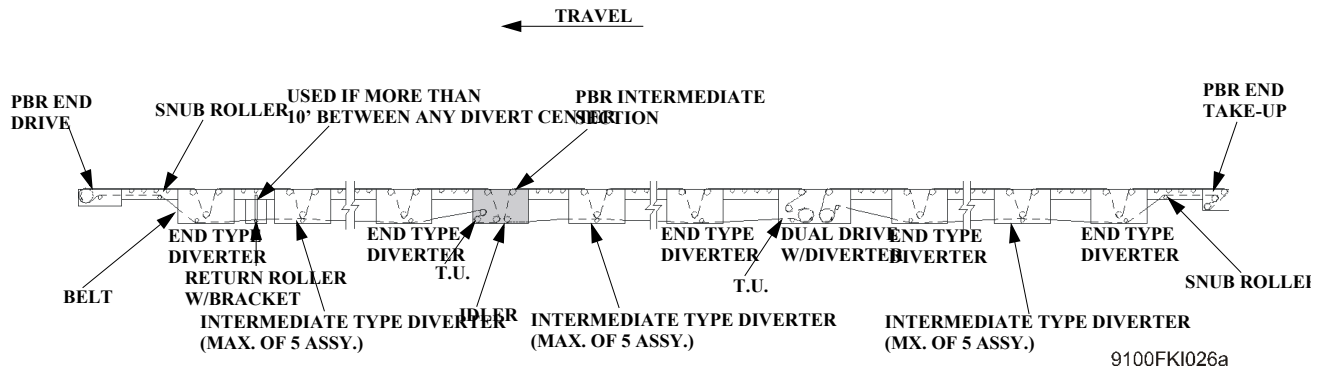

TAKE-UP/IDLER INTERFACE APPLICATION
 - ALLOWS CONNECTING TWO BELTS WITH INDEPENDENT DRIVE
 - CONTAINS OWN DIVERTER SECTION

Figure E - 5 Take-Up/Idler Interface

Figure E - 5 shows the Take-Up/Idler Interface being used to connect two separately powered belts. The upstream belt is powered by a Dual Drive and the downstream belt is powered by an 800 Series End Drive. This configuration allows for increasing the number of diverts in a UniSort IV without sacrificing a divert position.

Dimensions

Table E - 5 Single Drive w/Diverter Dimensions

Assembly name	Width	Length	Depth
End Diverter	18", 24", 30", 36"	30"	18 1/8"
Intermediate Diverter	18", 24", 30", 36"	30"	18 1/8"
Dual Drive w/Diverter	18", 24", 30", 36"	40"	20 1/8"
Take-Up/Idler Interface Diverter	18", 24", 30", 36"	30"	18 1/8"
PBR End Drive	15", 21", 27", 33"	24"	26" -31"
PBR End Take-Up Section	15", 21", 27", 33"	14"	10"
PBR Intermediate Section	15", 21", 27", 33"	*	5"

* Intermediate section recommended minimum length is 2 times width dimension. PBR End Drive depth depends on power unit horsepower.

SECTION F: ACCESSORIES

SECTION G: INSTALLATION PROCEDURES

Introduction

Accepting Shipment

Immediately upon delivery, check that all equipment received agrees with the bill of lading or carrier's freight bill. Any shipping discrepancy or equipment damage should be clearly noted on the freight bill before signing.

Shortages or Errors

Report any shortages or errors to the Manufacturer's Customer Service in writing within ten (10) days after receipt of shipment.

Note: It is very important that you compare the Order Acknowledgment against the actual material received when you receive the shipment so you have enough lead time to order any missing parts. If you find that a part is missing during assembly, you may have to discontinue assembly while you wait for the part to arrive.

Lost or Damaged Shipment

Report lost shipments to the Manufacturer's Shipping Department.

If shipping damage is evident upon receipt of the conveyor equipment, note the extent of the damage on the freight bill and immediately contact the transportation carrier to request an inspection. Do not destroy the equipment crating and packing materials until the carrier's agent has examined them. Unless otherwise agreed by the manufacturer, the Purchaser (User) shall be responsible for filing claims with the transportation carrier. A copy of the inspection report along with a copy of the freight bill should be sent to the Manufacturer's traffic department.

Claims and Returns

All equipment furnished in accordance with the Manufacturer's Agreement is not returnable for any reason except where authorized in writing by the Manufacturer. Notification of return must be made to the Manufacturer's Customer Service Department, and if approved, a "Return Authorization Tag" will be sent to the Purchaser (Users). The return tag sealed in the "Return Authorization Envelope" should be securely affixed to the exterior surface on any side of the shipping carton (not top or bottom), or affixed to any smooth flat surface on the equipment, if not boxed.

Send authorized return shipment(s) transportation charges prepaid to the address indicated on the Return Authorization Tag. If initial shipment is refused, the Purchaser (User) shall be liable for all freight charges, extra cost of handling, and other incidental expenses.

Codes and Standards

The conveyor equipment is designed and manufactured to comply with the American National Standard Institute's "SAFETY STANDARDS FOR CONVEYORS AND RELATED EQUIPMENT" (ANSI B20.1) and with the National Electrical Code (ANSI/NFPA70).

The Purchaser/Operator shall be familiar with, and responsible for, compliance with all codes and regulations having jurisdiction regarding the installation, use, and maintenance of this equipment. Appropriate lockout/tagout policy and procedures shall comply with the minimum

safety requirements outlined in the American National Standard Institute's current publication (ANSI Z244.1).

Warning Signs

Warning signs and labels posted on or near the conveyor equipment shall not be removed, painted over, or altered at any time. All safety devices, warning lights, and alarms associated with the conveyor system should be regularly tested for proper operation and serviced as needed. If the original safety item(s) become defective or damaged, refer to the conveyor parts list(s) or bill(s)-of-materials for replacement part numbers.

Safety Features

- DO turn off conveyor power source(s) and affix appropriate lockout/tagout device(s) to operating controls before servicing the equipment. ONLY trained and qualified personnel who are aware of the safety hazards should perform equipment adjustments or required maintenance while the conveyor is in operation.
- DO observe all warning signs, lights, and alarms associated with the conveyor operation and maintenance, and be alert at all times to automatic operation(s) of adjacent equipment.
- DO use extreme caution near moving conveyor parts to avoid the hazard of hands, hair, and clothing being caught.
- DO NOT sit on, stand on, walk, ride, or cross (over or under) the conveyor at any time except where suitable catwalks, gates, or bridges are provided for personnel travel.
- DO NOT attempt to repair any equipment while the conveyor is running, replace any conveyor component without appropriate replacement parts, or modify the conveyor system without prior approval by the manufacturer.
- DO NOT operate the conveyor until all safety guards are securely in place, all tools and non-product materials are removed from or near the conveying surfaces, and all personnel are in safe positions.
- DO NOT remove or modify any safety devices provided on or with the conveyor.
- DO NOT clear jams or reach into any unit before first turning off the equipment power source(s) and affixing appropriate lockout/tagout device(s).

Parts Replacement

To minimize production downtime, selected conveyor spare parts should be stocked for replacement of defective components when required. Refer to the equipment bill(s)-of-materials where quantity requirements or code numbers are not indicated on the conveyor parts list. A list of selected spare parts for standard products is included in this manual (see Section I).

Factory Assistance

Contact Field Service for installation, operation, or maintenance assistance, or Customer One Protection (COP) for replacement parts.

Installation Overview

This topic presents a recommended order for installation, final assembly, and alignment verification of the UniSort IV Sortation Conveyor. The remainder of this section provides detailed information.

The layout/installation drawings that should be referenced include:

- UniSort IV layout drawings that show type, location, and elevation of the UniSort IV sections and associated conveyors.
- Air piping/air connection drawing(s).
- Electrical layout drawing(s).

Installation and Assembly Steps

1. Verify receipt of the correct types and quantities of UniSort IV sections, installation hardware, loose parts, take-away conveyors, etc. as shown on the installation/layout drawings.

Note: The parts that are typically shipped loose include: carrying chains, carrying tubes (slats), divert pushers, air filter/regulator/lubricator, air pressure switch, variable speed controller, any additional air lubricators, supports, guardrail, PTO components (if applicable), chain track, and track splice joints.

2. Mark the Layout - Refer to the layout drawing(s) and mark the location and centerlines of the UniSort IV onto the floor or mezzanine. Perform this for each UniSort IV section and all associated infeed, discharge, and take-away conveyors shown on the layout drawing(s).
3. Pre-install Floor Supports and Ceiling Hangers.

Note: If the conveyor is to be located on an elevated structural steel platform, the platform should be in place and level along its entire length and width before installing any UniSort IV section see Product Manual 5310 *Floor Supports and Ceiling Hangers*.

4. Install Diverter.
5. Install Center Drive (if used).
6. Install Terminal Ends (can include End Take-up, End Drive, Idler Sections).
7. Install Powered Belt on Roller Intermediate Sections.
8. Install Intermediate Section(s) Floor Supports (if used).
9. Verify correct installation of all pre-assembled units. Pay special attention to verifying that the correct type of UniSort IV diverter unit is installed in the location specified by the layout drawing.
10. Check alignment and leveling of all installed units.
11. Install Take-Away Conveyors.
12. Install UniSort IV main line carrying belt.
13. Install Return Belt support bracket and roller (if used).
14. Install Air filter-regulator-gauge and Air Pressure Switch.
15. Install Air Piping. Make air connections.
16. Install Drive Motor Soft sSart(s).

-
17. Install Tracking Encoder(s) and Photo-Eyes.
 18. Install Control Panel(s) including Motor Starters, Relays, Fuses, Terminal Strips, Sorter Tracking Control Unit, etc.
 19. Install all Electrical Power and Control Wiring.
 20. Perform initial soft start adjustments. (Refer to Soft Start Manufacturers Manual.)
 21. Apply momentary power to drive motor(s) to verify correct rotational direction to drive motor(s).
 22. Perform initial main line belt tensioning and tracking adjustments.
 23. Perform final belt tracking adjustments.
 24. Perform final soft start adjustments. (Refer to Soft Start Manufacturers Manual.)
 25. Ensure proper adjustment of over-current electrical relays/sensors. (Refer to Manufacturers Instructions.)
 26. Set air pressure for 80 psi operating pressure.
 27. Check for correct height of all diverter unit pop-up wheels.
 28. Install product containment guard rail.
 29. Install personnel safety guards.
 30. Test run the completely installed UniSort IV with product being diverted. Make any necessary adjustments.

Installing the Conveyor

Installing Floor Supports to Diverters

See Product Manual 5310 *Floor Supports and Ceiling Hangers* for complete floor support installation instructions. The floor support information presented here provides additional information for the UniSort IV conveyors.

Pre-install the Floor Supports to each diverter before actually installing the diverters in place.

Note: The type FSM Floor Supports are used for the Diverters, End type Drives, Center type Drives, End Take-ups and Idler Section. Do not confuse with with FSMU4 type Supports used with Intermediate Sections only.

As shown in Figure G - 1, pre-installed two (2) FSM Type Floor Supports to each Diverter. The Floor Supports are located at each corner. Adjust Floor Support height as required.

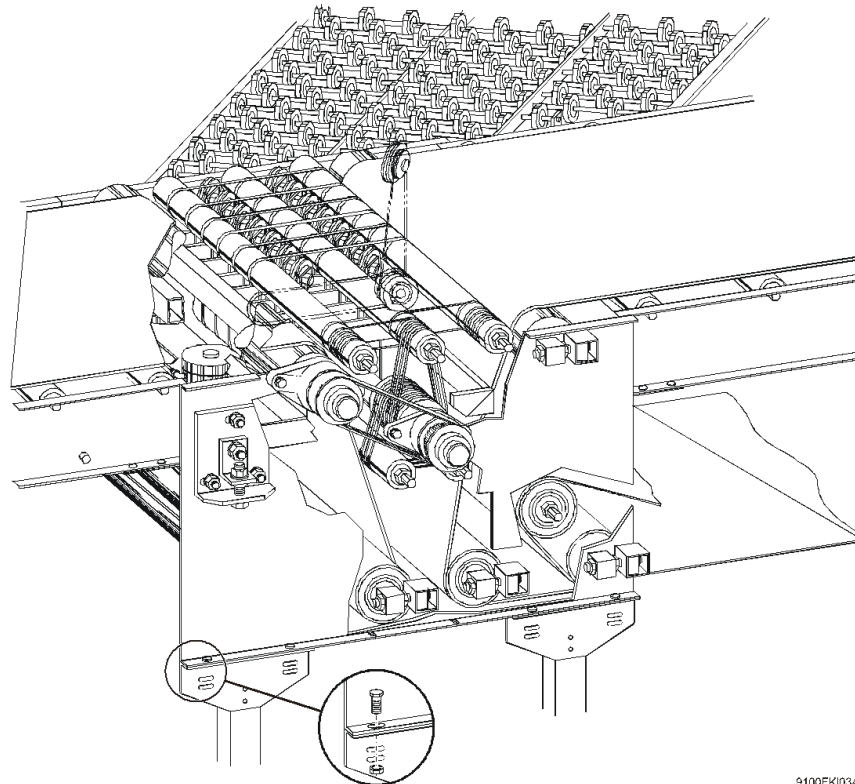

9100FKI034a

Figure G - 1 Installing Floor Supports to Diverter

If a Dual Drive or Single Drive with Diverter is included in the layout, a single leg FSM Floor Support is used to support the Drive Motor Mounting Plate. This support is in addition to floor supports mounted at each corner of the Diverter. Install the Single Leg Support as shown in Figure G - 2. Adjust height as required.

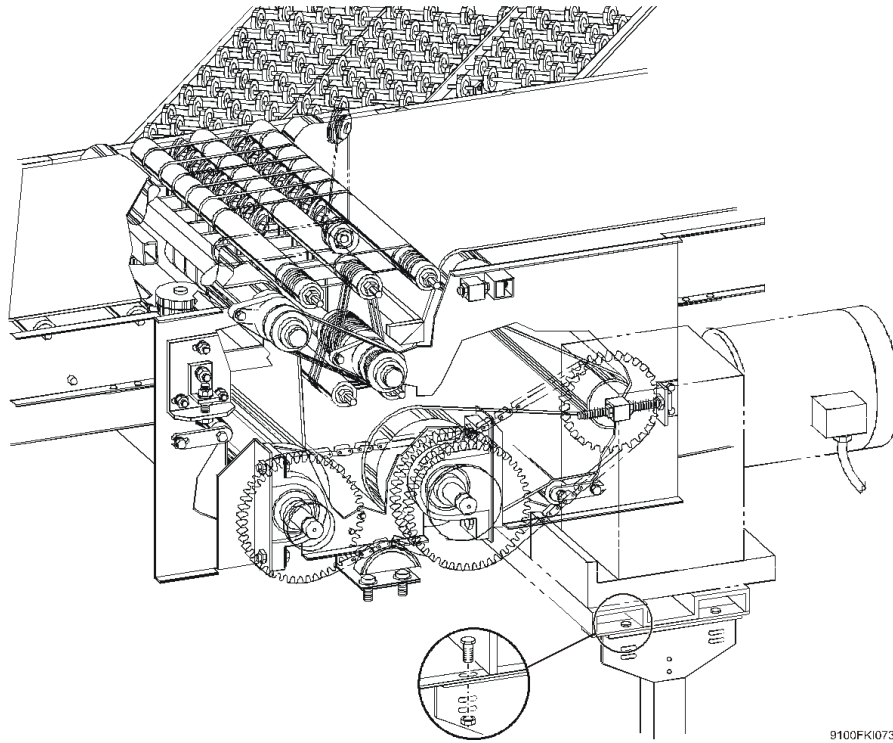
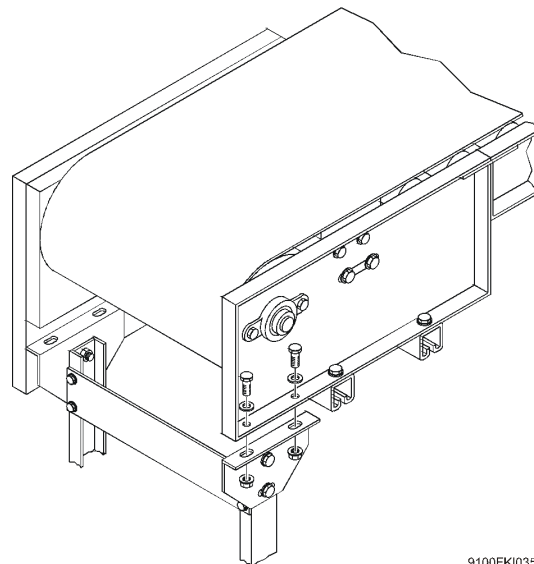

Figure G - 2 Single Leg Floor Support on Drive Motor Mounting Plate

Installing Floor Supports to End Drive, End Take-up, and End Idler Units

Type FSM Floor Supports are to be pre-installed to the 800 Series End Drive, End Take-up and End Idler units as shown in Figure G - 3.



End Drive Unit shown,
Power Unit not shown.

Figure G - 3 Floor Supports Mounted to Terminal End

Installing Floor Supports to Center Drive

The 800 Series Center Drive does not typically require floor supports.

Installing Ceiling Hangers

If Ceiling Hangers are to be used, the hangers should be pre-installed to the overhead structure of the building. See Product Manual 5310 *Floor Supports and Ceiling Hangers* for complete ceiling hanger installation instructions.

Installing Diverters

The Diverter units are to be set in place after the Floor Supports or Ceiling Hangers have been pre-installed.

CAUTION: There are six different types of UniSort IV Diverter units. Verify that the correct Diverter type is set in place as shown by the layout drawings.

Set the Diverters in place ensuring correct Diverter type, location and elevation. Align all Diverter units carefully before final fastening to floor, etc. Locate the Return Belt Snub Roller in all End Diverter units as shown by the installation drawing and as identified in Figure G - 4.

Note: Snub Roller located on side where Return Belt travels "UP".

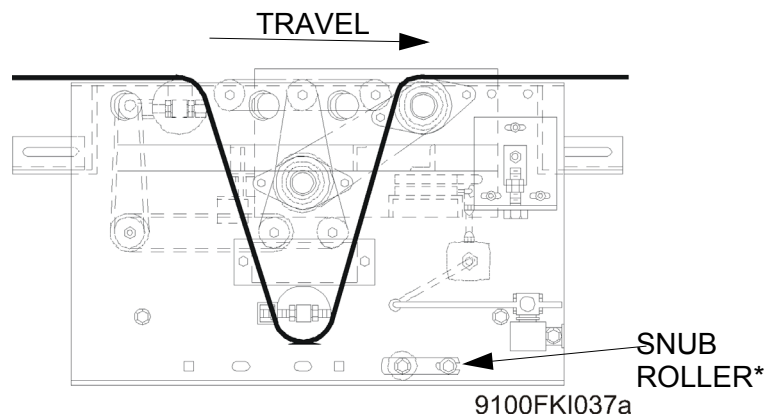

*Located on upstream or downstream side depending on layout.

Figure G - 4 End Diverter - Snub Roller Location

Installing Center Drive Unit

Set the 800 Series Center Drive unit, if used, in place as shown by the layout drawing. Refer to Figure G - 5 for correct installation of the Center Drive unit. Note location of Power unit with respect to direction of travel.

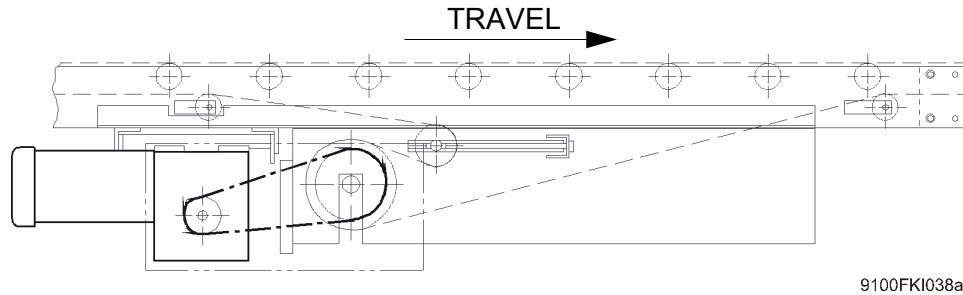

Figure G - 5 800 Series Center Drive Unit

Installing Terminal Ends

Identify and set the Terminal Ends in place. Terminal Ends include 800 Series End Drive (if used), End Take-up(s), Idler section(s). Verify correct Terminal End type, location, and alignment before final fastening to floor or to ceiling hanger.

Installing Powered Belt on Roller Intermediate Section

Install the Powered Belt on Roller Intermediate section (PBR-IS) starting at the infeed end. The Layout drawing shows the length of the different Intermediate sections to be installed. The identification labels also show the length.

PBR Intermediate sections are installed after Diverter units and Terminal Ends have been fully installed. End, Intermediate, Dual Snub, Take-up Idler interface, and Single Drive with Diverter have the same mounting for PBR Intermediate sections (Figure G - 6). The Dual Drive with Diverter uses a different mounting. It may also be necessary to field cut the PBR-IS before final installation of each individual section. Verify Intermediate section length before cutting.

A Splice Flat is used to connect together two PBR-IS as shown in Figure G - 7. A Splice Angle may also be used for retaining the load carrying capability.

Type FSMU4 floor supports are installed on PBR-IS are more than ten (10) feet long or when two sections are spliced together. See Product Manual 5310 *Floor Supports and Ceiling Hangers* for complete floor support installation instructions.

CAUTION: Ensure that type FSMU4 floor support is used for the PBR-IS. Only this floor support provides adequate side clearance for return run of this belt.

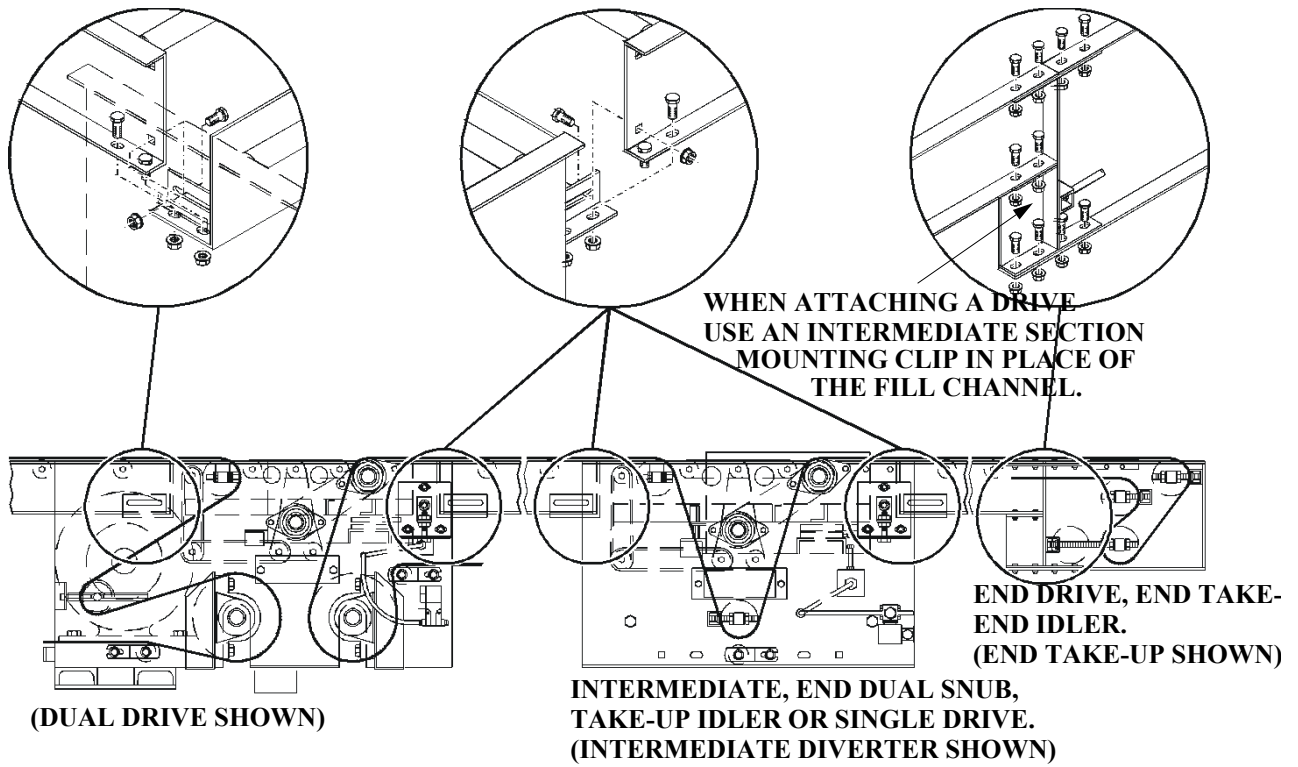

9100FK1039a

Figure G - 6 Installing Intermediate Sections

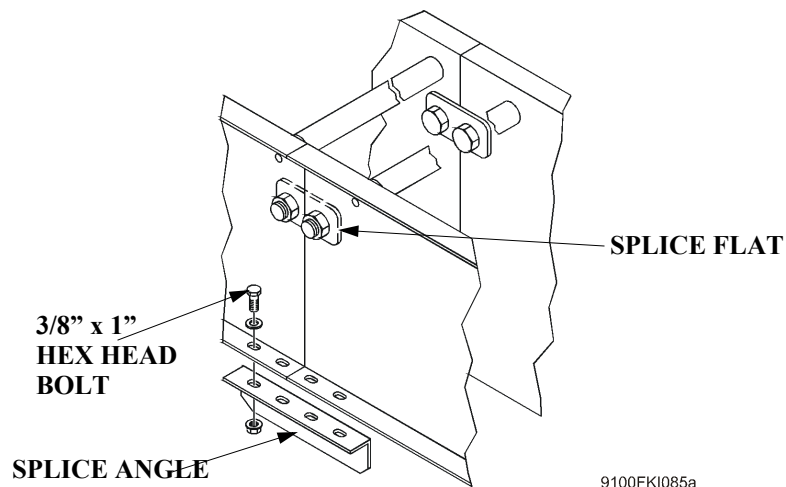

9100FK1085a

Figure G - 7 A Splice Flat Connection

Check for correct installation and alignment of pre-assembled units before proceeding:

1. Includes Diverter units, Terminal Ends, Intermediate sections, Floor Supports/Ceiling Hangers.
2. Refer to Layout Drawing.
3. Verify that all Diverter units are located correctly in terms of Diverter unit type and Drive unit horsepower of any Single or Dual Drive with Diverter units.
4. Verify correct installation of Terminal Ends (type and location) and of Center Drive (if used).
5. Check alignments carefully.

CAUTION: Any mis-alignments will affect belt tracking.

The following alignment checks should be performed:

1. Proper height of all Diverter units, Intermediate sections, and Terminal Ends.
2. All units are installed level. (No side to side tilt.)
3. No skew in the Intermediate sections.
4. Intermediate sections carrying rollers are on 8" centers not skewed.

Note: All Intermediate section return belt snub and idler rollers to be checked and located during belt installation.

Installing Take-Away Conveyors

Install Take-away conveyors to the divert side of all Diverter units. Figure G - 8 shows installation of the 45° Straight Gravity Wheel type Take-away conveyor. Figure G - 9 shows the location of Take-aways with respect to the Diverter.

Gravity Wheel Take-away conveyors should have a minimum 5/8" per foot pitch.

CAUTION: For reliable product diverting and conveying of diverted product, the Take-away conveyor must be located at the Diverter units as shown in Figure G - 9.

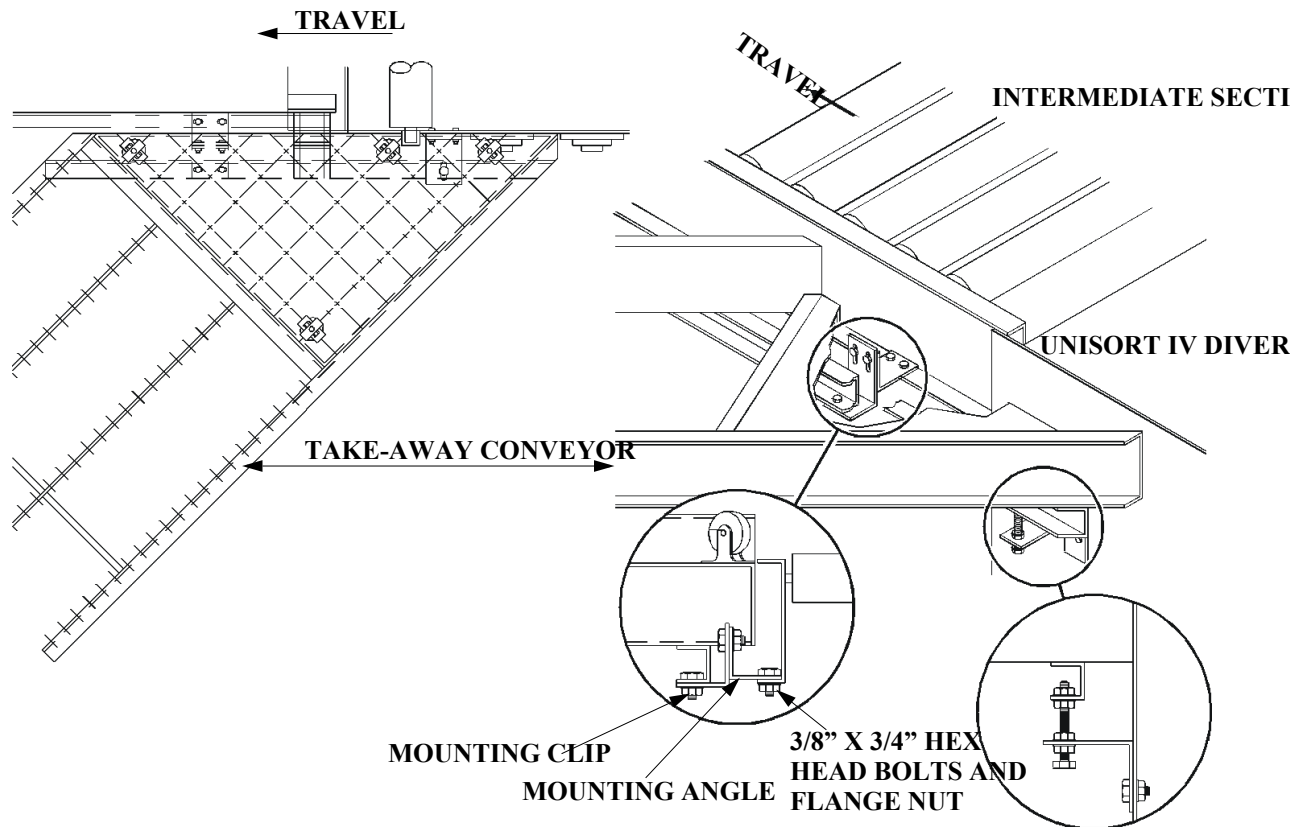

9100FKI041a

Figure G - 8 Take-Away Conveyor Mounting

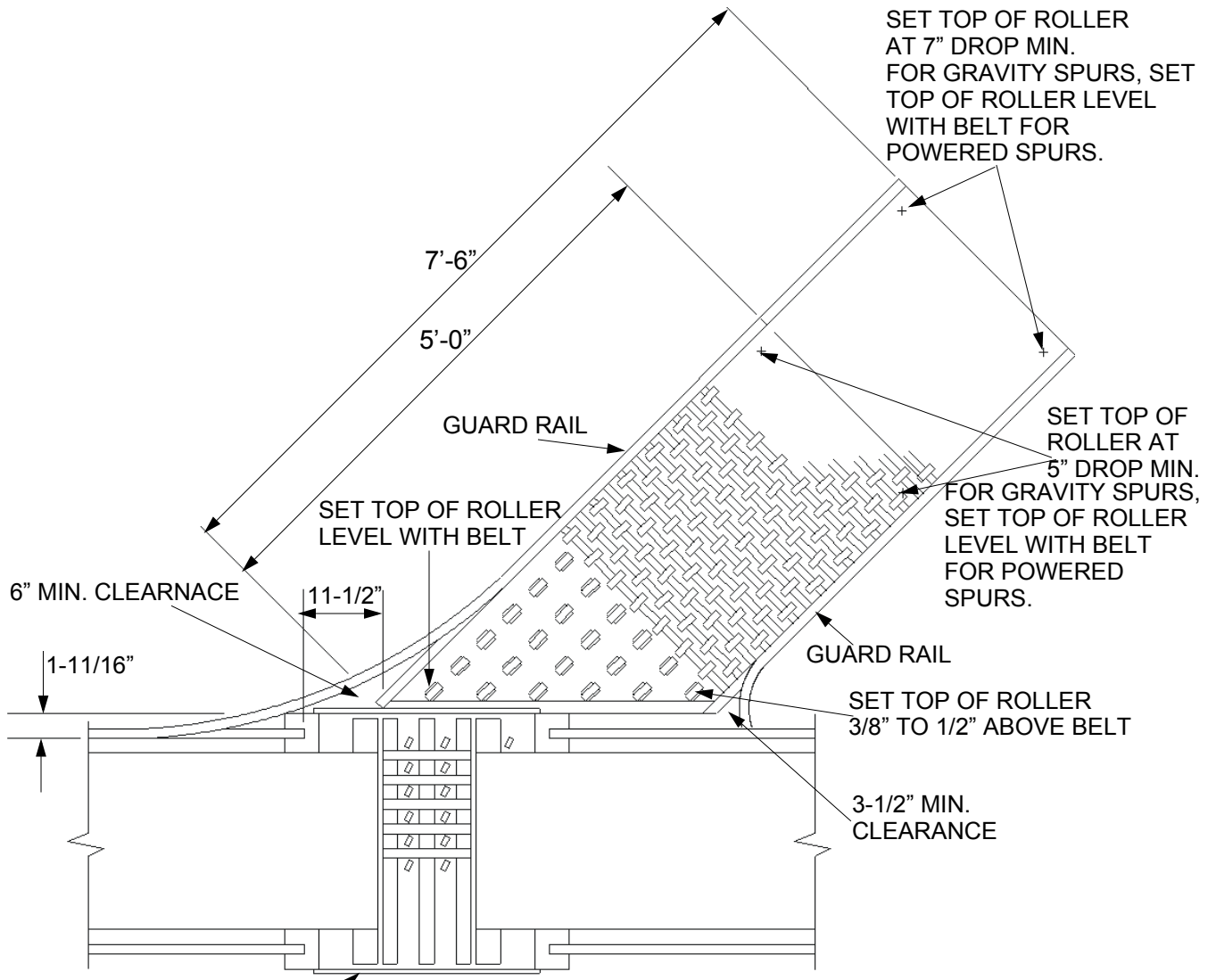

UNISORT IV DIVERTER ASSEMBLY
Figure G - 9 Take-Away Conveyor Location

9100FK1042a

Installing the Powered Carrying Belt

The procedure and order used for installing the powered belt consist of:

- Locating Return Belt Snub Rollers in End Diverters and Intermediate sections.
- Installing any required Return Belt Support Bracket with Roller.
- Initially adjusting all Take-up pulleys.
- Threading the belt.
- Cutting the belt square.
- Installing the clipper lacing.

Locating Return Belt Snub Rollers

The UniSort IV End Diverter is supplied with a Return Belt Snub Roller that must be field located based on the layout.

Refer to the layout drawing and verify that all the End Diverters have the Return Belt Snub Roller located on the side where the return belt is to travel up to an Intermediate section or to a Drive or Terminal End.

Return Belt Angle

The return belt angle is determined by Intermediate section lengths and placement of the Return Belt Snub Roller in the Intermediate section. Place all Return Belt Snub Rollers in the Intermediate sections to achieve a 45° or less return belt angle. This can be accomplished by having dimension “A” always greater than dimension “B” as shown in Figure G - 10.

Note: Intermediate section Return Belt Snub Rollers (251GHS) are shipped in the “Field Kit.” Return Belt Idler Rollers (G196GHS) are included with Intermediate sections.

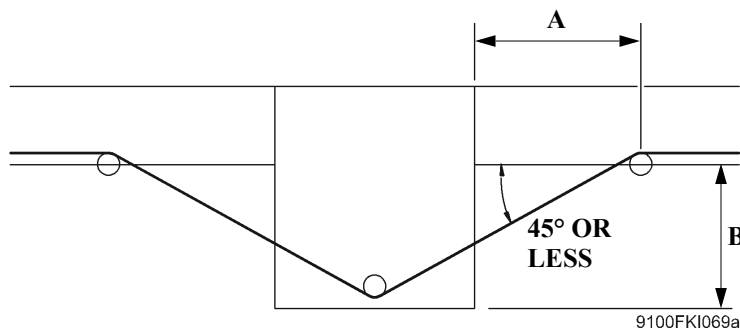

Figure G - 10 Return Belt Angle Example

Return Belt Support Bracket with Roller

The layout drawing shows the location of any applied UniSort IV Return Belt Support Bracket and Roller.

Refer to Figure G - 11 and install the Return Belt Support Bracket and Roller at locations indicated by the layout drawing.

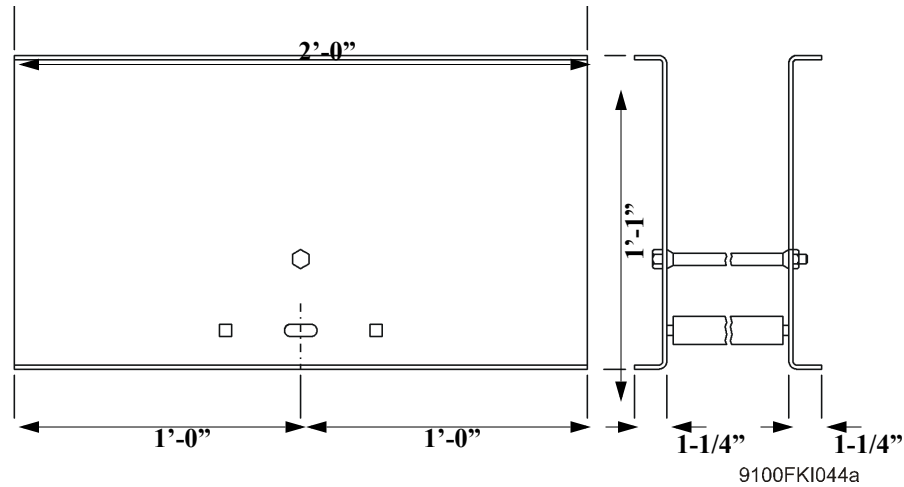

Figure G - 11 Return Belt Support with Roller

Take-Up Pulley Initial Adjustment

The Take-up Pulley should first be brought to within 1” of the position of minimum travel on the following units:

- Dual Drive w/Diverter unit
- Diverter w/Single Drive unit
- Take-up/Idler Interface units
- 800 Series Center Drive unit
- 800 Series End Take-up unit
- 800 Series End Idler unit

This is accomplished by turning the Take-up adjustment screws as shown in Figure G - 12, Figure G - 13, Figure G - 14, Figure G - 15, Figure G - 16, Figure G - 17, Figure G - 18, and Figure G - 19.

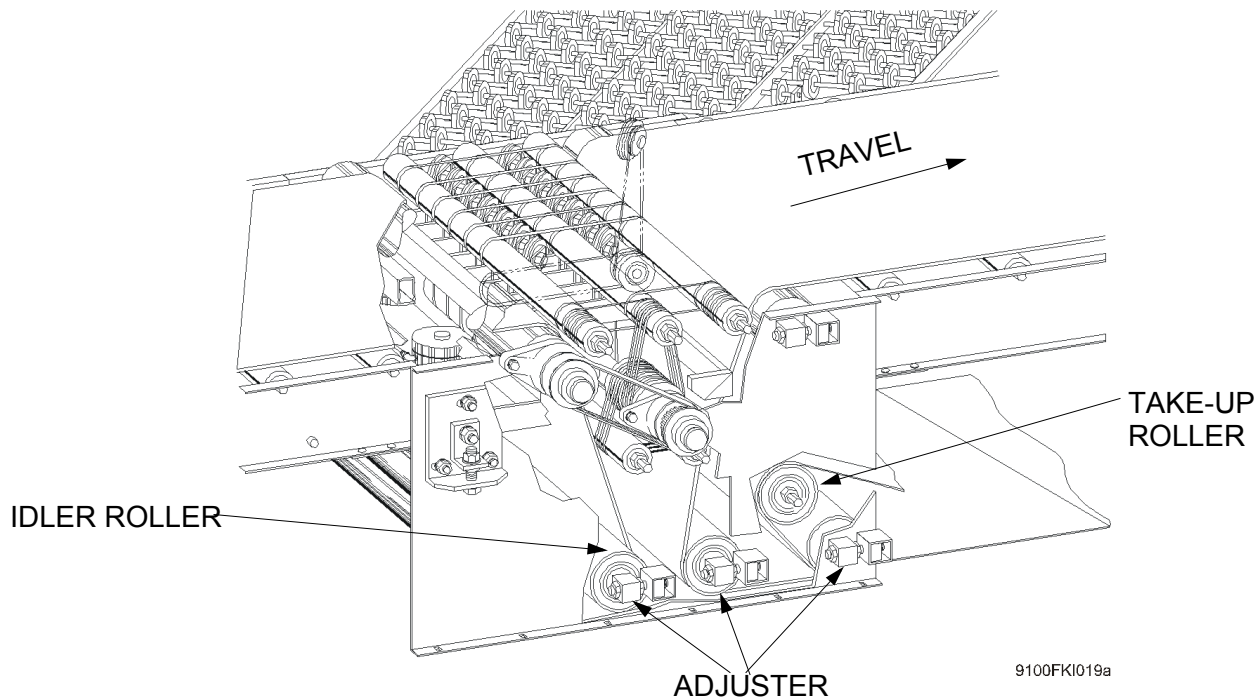

Figure G - 12 Take-up Idler/Interface Diverter

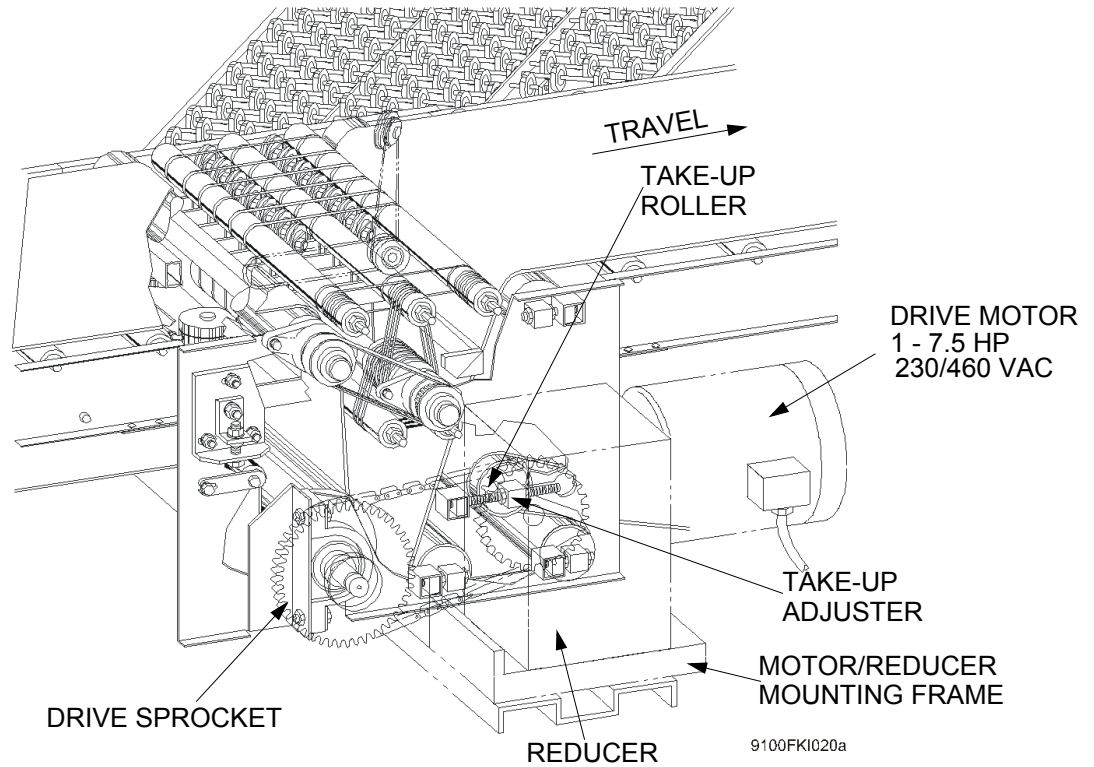

Figure G - 13 Diverter With Single Drive

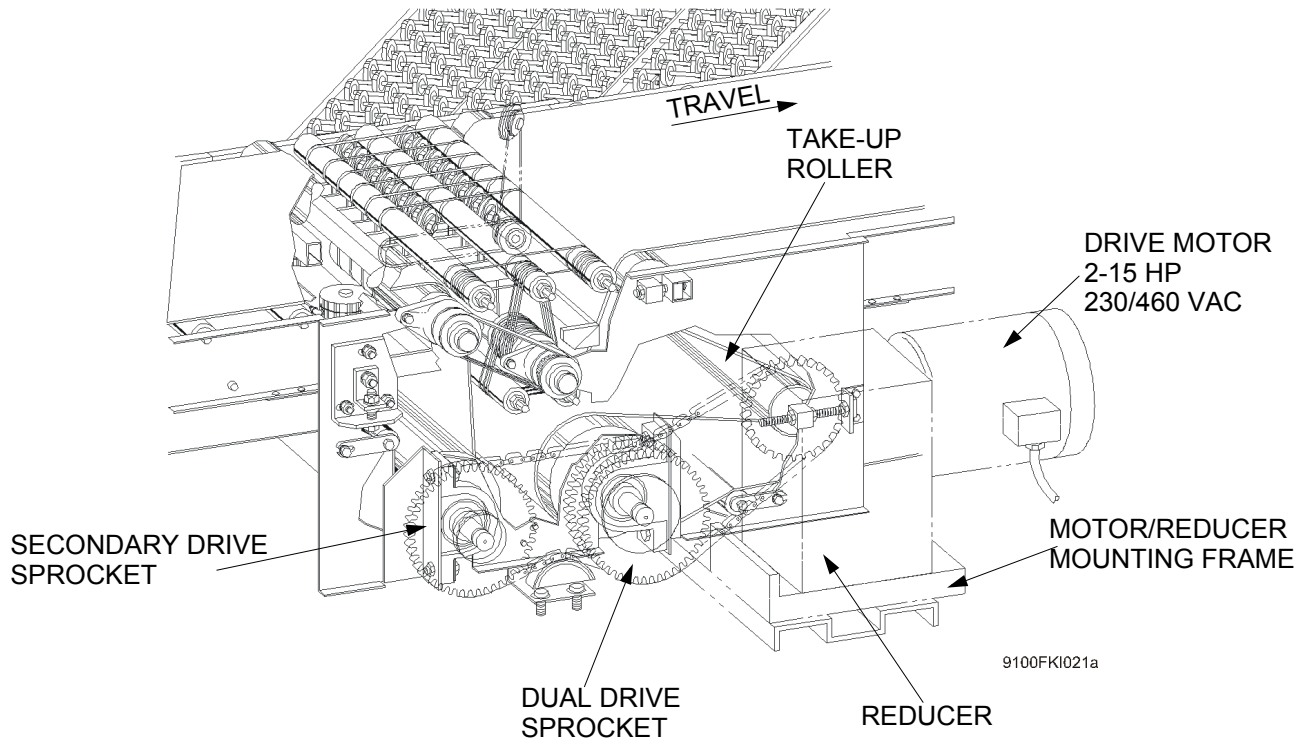

Figure G - 14 Diverter With Dual Drive

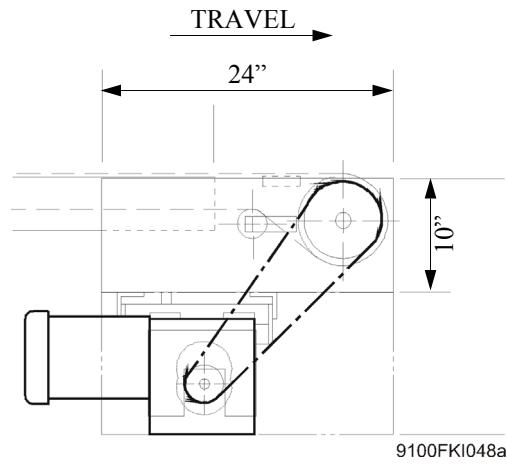

Figure G - 15 800 Series End Drive (Underhung Power Unit)

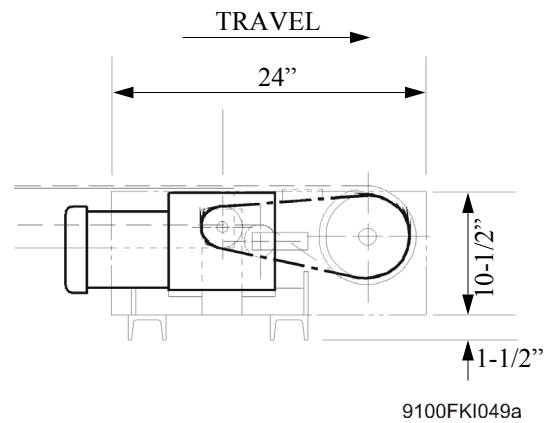

Figure G - 16 800 Series End Drive (Side Mounted Power Unit)

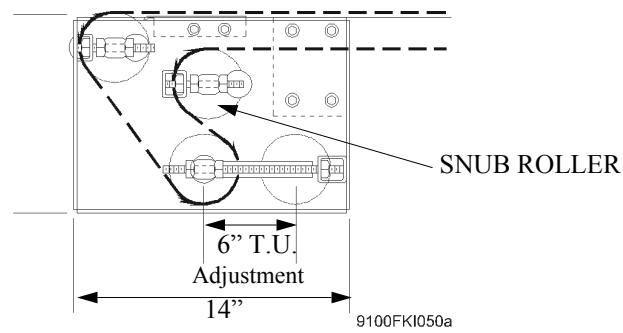

Figure G - 17 End Take-Up

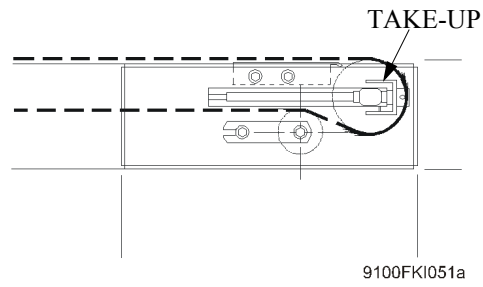

Figure G - 18 End Idler

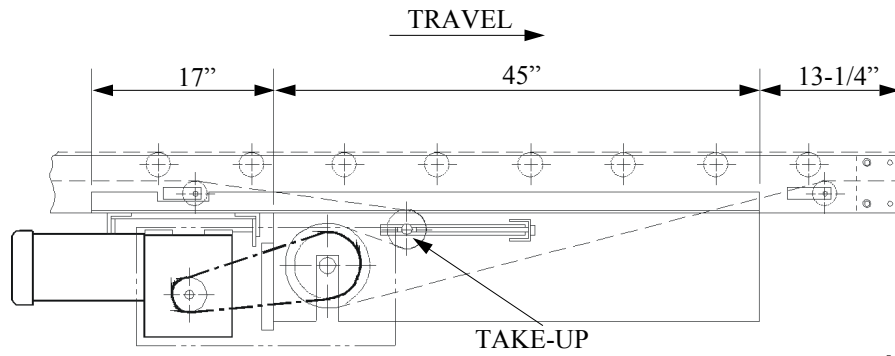

Figure G - 19 800 Series Center Drive

9100FKI052a

Threading the Belt

Refer to the layout drawing for determining the actual routing of the powered belt for your installation.

Note: The UniSort IV Dual Drive powers two belts. All other drive types power one belt. Drive belts are furnished in lengths to match the particular application. Verify correct belt length if more than one belt is to be installed and before threading the belt.

Starting at either end of the conveyor, thread the belt as shown in the layout drawing.

Pull the belt up and over the terminal end pulley(s) and bring the ends together on top of the bed as near to an End Idler/Take-up Pulley as possible. The belt is now ready to be cut and laced.

Note: Before cutting the belt, verify that the belt has been properly threaded through the various UniSort IV units.

Belt Cutting Procedure

Accurate squaring of the belt ends, prior to lacing, is excellent insurance against many common belt troubles. A properly squared belt tracks correctly and distributes stress evenly through the splice.

1. Always square from both sides of the belt (in case the sides are not parallel).
2. Draw the cut line, disregard the belt pattern which is not necessarily perpendicular to the belt edges.
3. Cut along the cut line using a straight edge and knife.

Belt Lacing Procedure

UniSort IV conveyors are furnished with Clipper brand belt lacings which require special lacing machines.

After cutting the belt square, stainless steel hooks are clinched into each end of the belt with a lacer machine. The ends are then brought together and the hooks are interconnected. A stainless steel connecting pin is then inserted through the joint, joining both ends of the belt together.

Should you experience any difficulties with the lacing or joining of the drive belt, please call for information.

This completes installation of the Powered Belt. Belt tensioning and belt tracking adjustments are to be done after installation of air piping and electrical power. For additional information, see the Product Manual 8100 *Powered Belt Conveyor*.

Installing Air Piping and Connections

To install the Air Piping:

1. Refer to your Air Piping layout drawing for Air Piping information. This drawing specifies the type, size, and location of air pipe and tubing as well as the location of the air filter/regulator/lubricator, air pressure switch, and any additional air lubricators. Figure G - 20 shows a typical UniSort IV Air Piping detail.

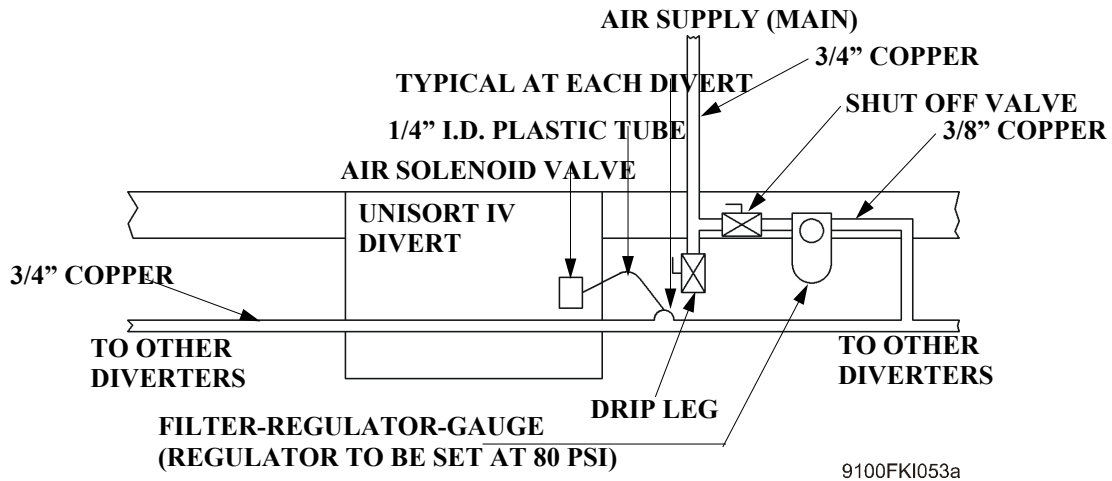

Figure G - 20 Air Piping Detail

2. Install the air filter/regulator/lubricator near or at the mid-point of the UniSort IV.
3. Adjust the regulator to 60 psi (side switch only) as indicated by the regulator gauge.
4. Depending on the UniSort IV layout, individual solenoid valve air lubricators may be required. Install these as shown on the Air Piping layout drawing.
5. Install the air pressure switch between the last and second last divert switch as shown in the figure. It is adjusted to “trip” whenever the air pressure falls below 50 psi.

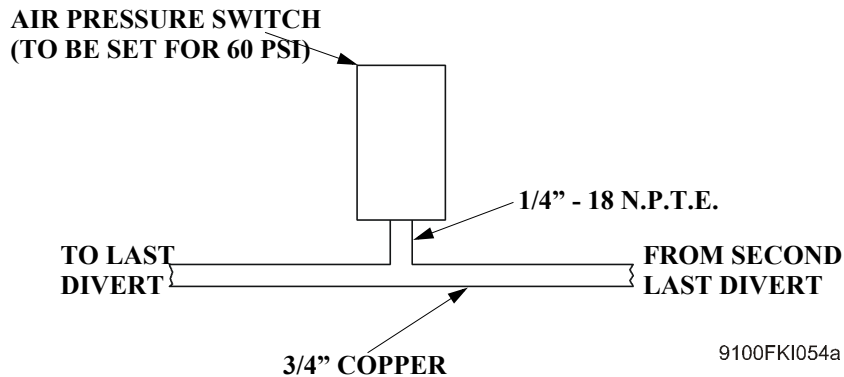

Figure G - 21 Air Pressure Switch Location

Installing Drive Motor Soft Start

A Soft Start is supplied for each UniSort IV drive motor. The soft start is mounted on the UniSort IV in an upright position and is close as possible to the drive motor. A minimum of six inch (6") clearance on top and bottom is required for adequate ventilation. Refer to electrical installation drawings and the Soft Start Manufacturer's Manual for specific mounting detail.

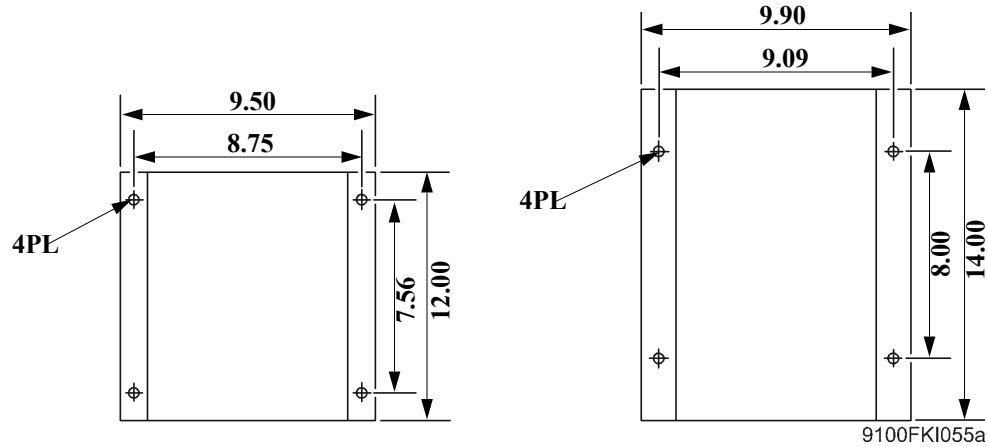

Figure G - 22 Soft Start Mounting Dimensions

Installing Electrical/Control Devices

Table G-1 shows the typical electrical/control devices that may be used for controlling a UniSort IV. Refer to the electrical installation drawings and materials list for the exact type, location, and wiring of each device used.

Table G-1 Electrical/Control Devices

Device	Function
Main Power Disconnect (may be 4-pole switch)	Switches power to the drive motor(s) and the control unit. The fourth pole switches power to the control unit. Located in the control panel.
Motor Starter(s)	Switches power to drive motor(s) via a motor disconnect switch and Variable Frequency Drive. Contact status may be supplied to control unit. Located in control panel.
Motor Disconnect	Switches power to the drive motor via the Variable Frequency Drive. The contact status is typically supplied to the control unit.
Soft Start	Effects smooth start-up acceleration of the drive motor. Typically wired between drive motor and motor disconnect switch. One Soft Start used per drive motor. Located on the UniSort IV.
Emergency Stop Push Button/Pull Cord	Used to drop power to the drive motor(s). The contact status is typically supplied to the control unit. Located on the UniSort IV.
Air Filter/Regulator/Gauge	Adjusted to supply filtered 80 psi operating air pressure for pop-up air cylinders. Connected to main air supply. Located on UniSort IV.
Air Solenoid Valve	110 VAC actuated valve for switching air to pop-up air cylinders for diverting. (Valve and air cylinder are supplied with each Diverter unit.) Located on each Diverter. NOTE: UniSort IV requires 80 psi air; pressure switch field adjusted to sense below 60 psi air pressure. Located on the UniSort IV.
Air Pressure Switch	Detects low operating air pressure. The contact status is typically supplied to the control unit.
Induction Photo-Eye(s)	Located on the UniSort IV. Detects the leading edge of product entering the UniSort IV so the product can be tracked. Photo-eye placed at upstream end (infeed end) of each UniSort IV belt section.
Lane Full Photo-Eye	Located on each take-away conveyor (sort lane) at the point where the take-away lane is considered full. Oriented at an angle so product is detected even if small gaps between product exists. Typically used with a 3-7 second delay timer. Lane is considered full if photo-eye remains blocked for that period of time. Product diverting to the lane is then inhibited.
Update Photo-Eye	Located on UniSort IV immediately upstream of each third Divert assembly. Use to adjust product tracking array in event product has slipped on the PBR belt.
Product Jam Detect Photo-eye	Located at extreme up-stream end of each Take-away (Sort Lane) conveyor. Oriented perpendicular to product flow direction. Used with 3-7 second time delay. Product jam condition indicated when product blocks entrance to Take-away conveyor for that period of time. Diverting to that lane is inhibited and power to the UniSort IV may be dropped.

Table G-1 Electrical/Control Devices

Device	Function
Tracking (Pulse) Encoder	<p>Used to measure (track) product moving along UniSort IV belt. A 4 pulse per revolution encoder is typically used to provide a tracking resolution of 2.5 inches.</p> <p>Encoder is attached to end of PTO pulley. End is supplied drilled and tapped to permit encoder installation.</p>

Installing Electrical Power and Control Device Wiring

Install wiring from the control panel to all electrical/control devices on the UniSort IV according to the electrical layout drawing. Figure G - 23 shows a typical UniSort IV drive motor wiring diagram.

Refer to the appropriate manufacturer’s instruction manual(s) for wiring Variable Frequency Drive(s), over-current relay(s), air pressure switch(es), and photo-eyes.

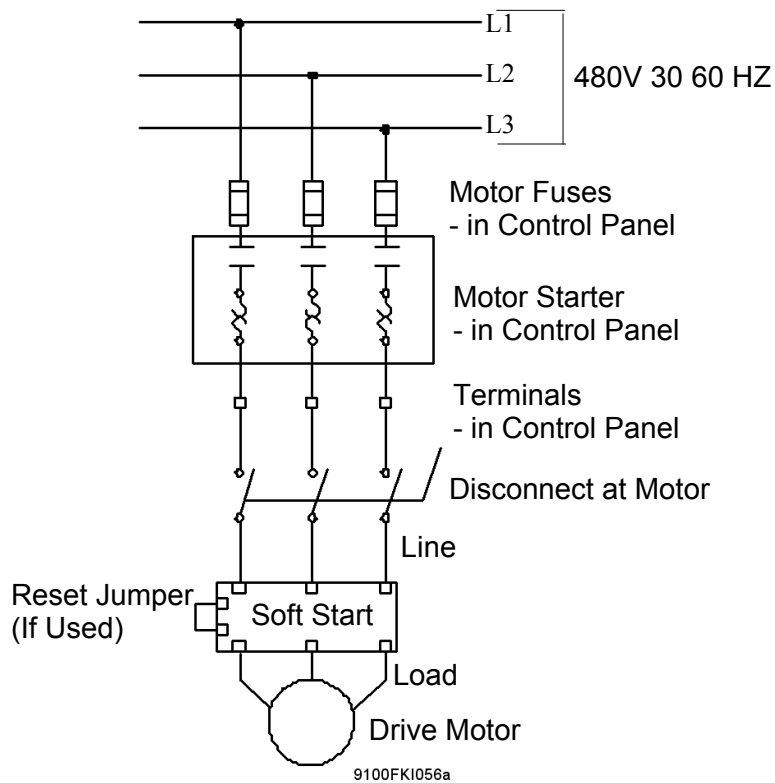

Figure G - 23 Unisort IV Drive Motor Wiring Diagram (Example)

Note: Soft starts to be mounted near motor. Refer to manufacturer’s instructions for actual wiring and adjustment procedure.

Initial Soft Start Adjustments

Refer to the *Soft Start Manufacturers' Instruction Manual* and perform any required adjustments prior to applying power.

Verifying Correct Drive Motor Rotation

CAUTION: Before applying power, review the safety check in **Before Applying Electrical Power** to ensure the safety of personnel.

1. Be sure the drive motor wiring is correct.
 2. Remove the V-belt drive.
 3. Apply momentary power to the drive motor(s) and check the direction of rotation.
 4. Re-install the V-belts.
-
-

CAUTION: A drive motor wiring error can result in reversed motor operation and/or possible drive motor damage.

Initial Belt Tensioning and Tracking Adjustments

Manually center the Belt as best as possible.

The belt is tensioned by adjusting the appropriate take-up pulley. Take-up Pulleys are used in the following units.

- 800 Series End Take-up (Figure G - 15)
 - 800 Series Center Drive (Figure G - 19)
 - 800 Series End Idler (Figure G - 18)
 - Dual Drive w/Diverter (Figure G - 13)
 - Single Drive w/Diverter (Figure G - 12)
1. For each belt used in the total UniSort IV Sorter layout, refer to the layout drawing and determine the type of unit in which the take-up pulley is located.
 2. Adjust the take-up pulley so that the belt tension is just tight enough to prevent belt slippage on the drive pulley. Adjust both sides of the take-up pulley equally and in 1/2 turn increments.
-
-

CAUTION: Excessive belt tension will reduce the life of the belt lacing, snub rollers and pulley bearings.

Belt Tracking Adjustments

Electrical power to the UniSort IV Drive Motor must be applied for initially checking and performing the belt tracking adjustments. For ensuring the safety of personnel and to minimize the possibility of damage to the UniSort IV, the following checks should be made before applying electrical power.

1. Check that the belt has been correctly threaded.
2. Check that the lacing connection has been securely made.
3. Check for proper and correct electrical connections. Verify power rotation of the drive motor.
4. Check that the soft start has been initially adjusted per the manufacturers instructions.
5. Check that the gear reducer in the power unit has the proper oil and oil level and the breather plug (if required) is correctly installed.
6. Check that all foreign objects are moved.

CAUTION: Belt tracking is most readily accomplished while the conveyor is running and must therefore be recognized as being dangerous. Only trained and qualified personnel should perform this adjustment. They must be instructed to always be alert for any unsafe condition and to use extreme care when tracking the belt.

Principles of Belt Tracking

Being able to successfully accomplish belt tracking is greatly dependent upon the alignment of all the UniSort IV Diverters and sections. Verify that all Diverters, Intermediate Sections and Terminal Ends are parallel to the center line of travel and are level side-to-side over the entire length of the UniSort IV.

Verify that all UniSort IV rollers and pulleys are at a right angle to the frame.

Verify that the belt is correctly tensioned so not to slip on the drive pulley. The belt is tensioned by adjusting the appropriate take-up pulley. Adjust each take-up pulley side the same amount. (See belt tensioning adjustments).

Crowned pulleys are used to help keep the belt on center. This is because belts tend to run toward the part of the pulley which is largest in diameter.

The belt will always creep toward the side where shaft centers are not exactly parallel and are the closest to each other. In the UniSort IV, only the snub rollers need to be adjusted to track the belt thus compensating for non-parallel pulley shafts. All adjustments should be slight with time allowed for the belt to react to the adjustment.

During product travel, if the belt creeps to the right on the tail pulley, adjust the right side of the snub roller in direction "R" and/or to the left side in direction "F".

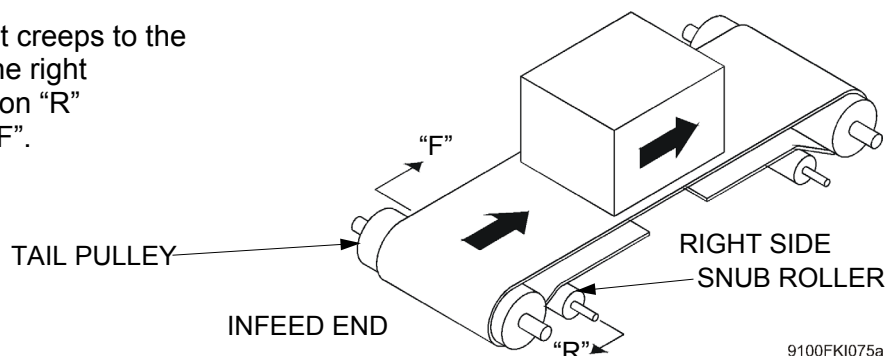

9100FKI075a

Figure G - 24 Belt Tracking Example

Note: The procedure is for each belt used in the UniSort IV Sortation Conveyor.

1. Verify that all safety checks have been performed
2. Verify that the conveyor has been correctly installed and aligned.
3. When performing first time belt tracking adjustments it is good practice to station a person at each 50 foot point of the UniSort IV length with one person at the infeed and discharge end.
4. Apply power to the conveyor and note where and to what side the top run of the belt moves toward. For first time belt tracking, concentrate only on tracking the top run of the belt.

Note: If there is any severe belt mis-tracking, turn power off immediately and recheck alignments.

5. Adjust the appropriate snub roller(s) as shown in Figure G - 12 through Figure G - 19. Start at the first mis-tracking point and work down the UniSort IV in the direction of travel.
6. Track the return run of the belt in the same fashion except start at the discharge end and work towards the infeed end.
7. Recheck all belt tracking adjustments. The belt is properly tracked when the edges of the belt are equidistant from the UniSort IV's side frames.
8. Recheck belt tensioning adjustments while causing the Diverter wheels to cycle up and down. Re-adjust appropriate take-up pulley as required.

Note: Always recheck belt tracking after making any belt tensioning adjustments.

Final Adjustments

1. Perform final Soft Start adjustments using procedure in Soft Start manufacturers manual.
2. Verify correct setting of Over-Current Relay / Sensor.
3. Verify air pressure is set for 80 PSI at the Air Filter/Regulator Gauge.
4. Verify low Air Pressure Switch is set to trip at 60 PSI
5. Check Diverter Unit pop-up wheel height adjustment.

The UniSort IV diverter wheel assembly pop-up height has been factory adjusted for the tops of the second row of wheels to extend 3/8" to 1/2" above the flat belts when in the pop-up position. (See Figure G - 25.)

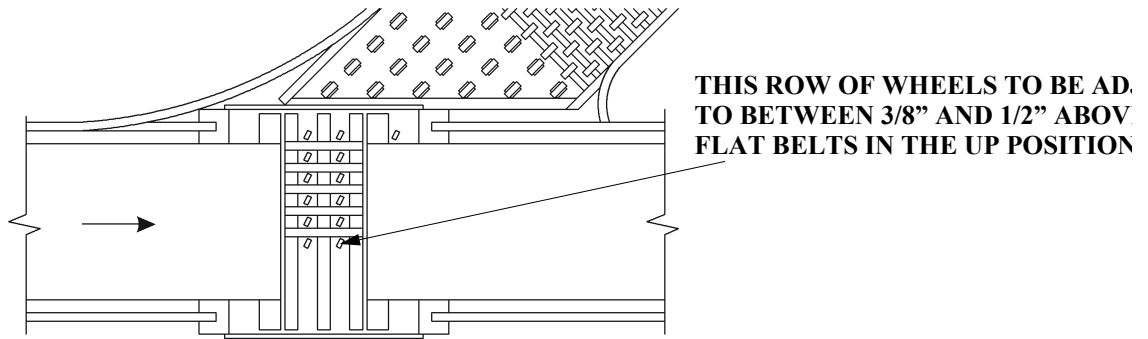

9100FKI076a

Figure G - 25 Adjusting the Diverter Wheels

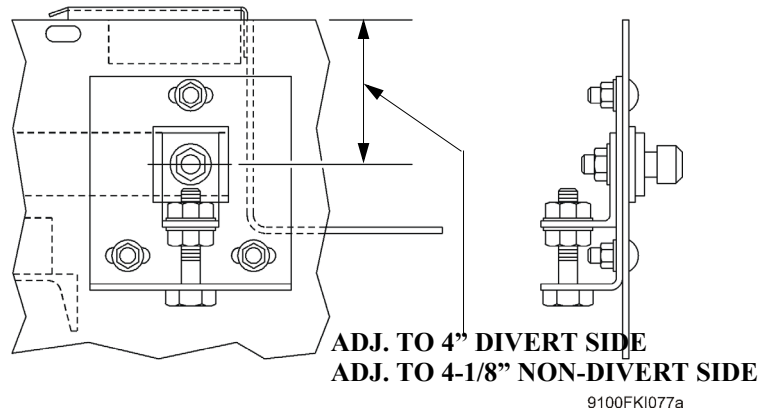

9100FKI077a

Figure G - 26 Pop-Up Wheel Adjustment

Using the following procedure if field adjustment is required:

1. Place the diverter pop-up wheel assembly in the "up" position. Requires 80 PSI Air and 110 VAC signal applied to the diverter's Air Solenoid Valve.
2. As shown in Figure G - 25 and Figure G - 26, use the height adjusters on the sides of the diverter unit to adjust.
3. Remove the 110 VAC signal and verify that the pop-up wheel assembly is in the "down" position and that the tops of all diverter wheels are below the flat carrying belts.

Installing Product Containment Guarding

The Product Containment Guarding is typically installed after all the installation adjustments have been made.

The UniSort IV uses two different types of guard rail:

- Type F, 5-1/2" high
- Type G, 11" high

In addition, 3 foot long section of notched guard rails are provided for mounting to the non-divert side of the UniSort IV Diverter. The notching allows clearance for the top rollers in each Diverter Unit, see Figure G - 28.

Refer to Figure G - 27 and Figure G - 28 for installing the guard rail.

Check the alignment of the vertical surfaces before final tightening of the bolts. Smooth joints will ensure trouble-free operation. Special attention should be paid to ensure that the guard rail on the divert side and at the divert points will not interfere with the diverting or smooth taking away of products.

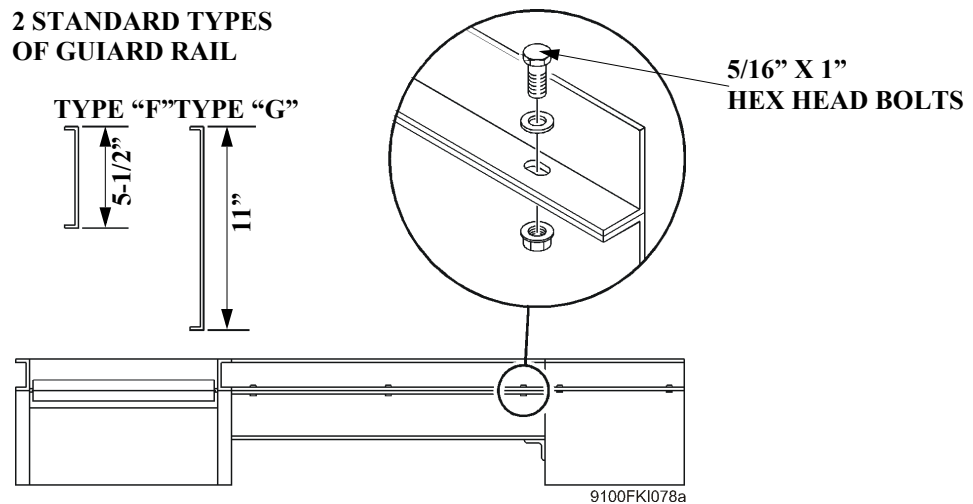

Figure G - 27 Installing Guard Rail

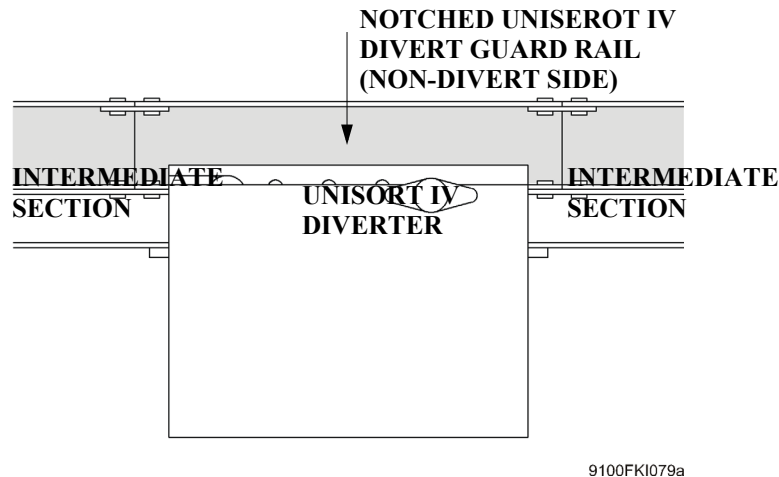
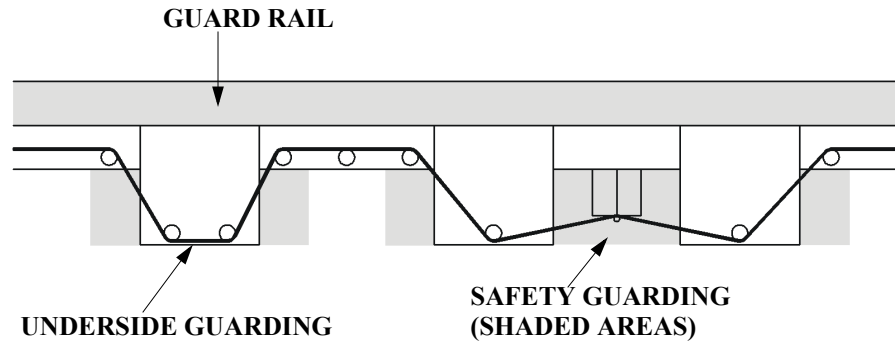

Figure G - 28 Notched Guard Rail

Installing Personnel Safety Guards

Personnel safety guarding is provided to prevent possible personal injury to any person coming into accidental contact with any moving part of the UniSort IV.

As shown in Figure G - 29, these areas include edge and bottom surfaces of the belt return run, pinch points, and diverter unit top and bottom surfaces.



9100FKI080a

Figure G - 29 Location of Personnel Safety Guards

Refer to the installation / layout drawing for installing the provided personnel safety guarding.

The UniSort IV Power Units are supplied with guards that fully enclose the sprocket drive chains. If any of these guards have been removed during installation, be sure they are re-installed before approving the installing for production.

Final Soft Start Adjustments

Refer to the *Soft Start Manufacturers' Manual* and perform final adjustments with power applied.

When the Soft Start is correctly adjusted, the UniSort IV will smoothly accelerate to operating speed with no jerking of the carrying chains.

Drive Over-current Relay/Sensor Adjustments

The drive over-current relay/sensor is adjusted to match the drive motor's starting current as listed on the motor's name plate. Refer to the manufacturer's instruction sheet for adjusting the over-current relay/sensor.

Air Pressure Adjustment

To set the air pressure, adjust the air regulator located on the UniSort IV. Set the air regulator to 60 psi (as indicated on the regulator gauge).

Air Pressure Switch Adjustment

The air pressure switch is set to actuate if the air pressure is 10 psi less than the required operating air pressure. Refer to the manufacturer's instruction sheet for adjustment instructions.

Final Testing

1. Test run the completely installed UniSort IV with product being diverted.
2. Check for smooth start-up of the UniSort IV when power is applied.
3. With product being diverted, verify that product is being smoothly and correctly diverted onto the correct take-away conveyors.
4. Be sure that installed guard rail will not result in product jams.
5. Check all safety devices to be sure they operate as designed.
6. Be sure that all safety labels are in place and guarding installed.
7. Ensure that the belt is properly tracked and does not come in contact with the “kicker” pop-up wheel in any of the Diverter units.
8. Make any necessary adjustments.

Checking Safety Features

Installing Product Containment Guarding

The product containment guarding is typically installed after all the UniSort IV installation adjustments have been made. For information on the installation of guarding, see the Product Manual 5320 *Side Guides*.

CAUTION: Be careful when installing the product containment guarding on the divert side. Be certain the guard rail does not interfere with the movement of diverted product.

Installing Personnel Safety Guarding

The personnel safety guarding prevents people from coming into contact with the moving parts.

To install personnel safety guarding refer to the installation/layout drawing because requirements vary by installation.

CAUTION: Personnel safety guards fully enclose the drive section V-belts (or drive chain). If these guards were removed during installation, reinstall them before approving the installing for production.

Final Installation Adjustments

CAUTION: Electrical power must be applied to perform the final checks. To ensure the safety of personnel and minimize the possibility of damage to the sorter, verify all of the following before applying electrical power.

After Applying Electrical Power

After applying electrical power:

1. Verify Soft Start adjustments following the manufacturer's instructions.

Note: When correctly adjusted, the Soft Start will allow the conveyor to smoothly accelerate to operating speed with no jerking of the carrying chains.

2. Observe the carrying belts, they should travel smoothly around each of the pulleys located in the drive section and the idler section.

CAUTION: If any adjustment is required, be sure the main electrical power switch is in a locked OFF position and tagged to prevent accidental application of electrical power.

3. Check the operation of all safety devices.

SECTION H: MAINTENANCE

Introduction

Recommended service checks and equipment maintenance are outlined in this section for typical, intermittent-duty conveyor applications. Additional maintenance and servicing schedule adjustments may be required for continuous-duty operation or extreme environmental conditions.

The indicated preventive maintenance time intervals are based on a UniSort IV which is operating eight hours per day in at or above freezing (40° F to 110° F) environmental temperatures.

All newly installed equipment should be frequently inspected and serviced as needed during the first 40 hours of operation; thereafter, an appropriate maintenance program should be established and followed (see Table G.1). The time intervals should be appropriately adjusted for more than eight hours per day operation and/or operation in a harsh environment. Also, sorting product that produces an extraordinary amount of dust, dirt or any other type of contamination may require more frequent preventive maintenance.

Maintaining separate service log sheets on each type of conveyor is recommended for plants operating more than one shift. Each log sheet should show dates, detailed inspection service information, and name or initials of person(s) performing the equipment inspection or service for future reference.

CAUTION: Before performing maintenance on a conveyor, make certain that the conveyor's power disconnect is locked in the "Open" position and tagged to prevent the accidental or unexpected application of power.

Do not perform maintenance while the conveyor is running unless specifically instructed to do so in this manual.

Note: Other than checking of chain tension, it is NOT necessary to have the conveyor turn ON to perform any of the work described in this section.

Maintenance must be performed only by qualified personnel who are trained in normal and emergency operations of the conveyor, and who are knowledgeable about all safety devices, their locations and functions.

Before restarting a conveyor:

- Remove all foreign objects from the conveyor.
- Be sure that all guards and safety devices are properly installed and working.
- Make sure that all persons are clear of the conveyor and are aware that the conveyor is about to be restarted.

Intervals indicated for performing maintenance should be considered for 8 hour per day operation. An application may subject the equipment to conditions that would necessitate more frequent maintenance. This may best be determined by performing maintenance more frequently when the conveyor is first put into operation, and then lengthening the intervals based on experience.

Table H-1 Scheduled Maintenance Summary

Interval	Components	Noise	Temperature	Bolts	Oil Level	Lubrication	Set Screws	Tensioning	Wear	Alignment	Proper Position	Physical Condition	Structural Damage	Safety Devices	Supports
Weekly	Belts and O-rings							X	X	X					
	Bearings	X	X												
	Reducer				(1)	*									
	Drive Chain and Sprockets	X													
	Belt Lacing											X			
	Safety Guards										X	X	X	X	
	General Structure											X	X	X	X
Monthly	Reducer				(2)	(2)									
	Drive Chain and Sprockets					(3)									
	Drive Pulley Hub						X								
	Drive Pulley Lagging								X			X			
500 Hours Quarterly	Belts and O-rings											X			
	Bearings			X		X									
	Reducer				(1)										
	Drive Chain and Sprockets								X	X					
	Rollers											X			
1000 Hours	Bearings											X			
	Reducer											X			
	Drive Chain and Sprockets											X			
	Drive Pulley Hub											X			
	Drive Motor	X	X	X								X			

(*) Inspect for oil leakage.

(1) Follow reducer manufacturer's instructions.

(2) Follow reducer manufacturers instructions as related to initial oil change.

(3) Check for proper oil level and operation of automatic drive chain lubricator or single and dual drive with diverter units.

Caution: Synthetic type lubricant may be used in the reducer. Pay special attention to the reducer's manufacturing specifications on lubricant type, frequency to changing, and operating oil level.

Daily Inspections

Perform walk-through inspections of the conveyor equipment each day. For continuous duty applications, conduct inspections each shift. Listen for unusual noises and carefully observe the system.

To ensure the safety of personnel, frequently check safety guards, warning signs, lights, and alarms associated with the UniSort IV, and keep them in good condition. Immediately report and correct any unusual noise, oil leak or operational problem.

Weekly Inspections

Perform the following component checks with **no power applied to the UniSort IV**:

1. Belts and “O” Rings - check for proper tension, alignment, and signs of wear.
2. Reducer - any evidence of oil leakage. Immediately check oil level if any leakage is noticed. Replace reducer if oil leakage persists.
3. Belt Lacing - tightness of the lacing. Replace the lacing if damaged.

Note: If the lacing must be replaced and the take-up adjustments permits, cut both ends of the belt squarely and install new lacing. If there is not sufficient take-up adjustment (belt too short), it is possible to splice in a minimum one foot long section of carrying belt.

4. Safety Guards/Devices - check for proper position and functioning of all safety guards and devices. Replace if any are damaged or defective.
5. General Structure - Check for any loose fasteners, damaged supports and guarding and any build up of rust or product spillage. Tighten and clean as required. Replace any damaged supports (or hangers) and guarding. Verify proper alignment.

Check the following components while the UniSort IV is operating:

CAUTION: Ensure safety of personnel while performing these checks.

1. Belts and “O” Rings - check for proper tracking of the carrying belt. Adjust as required. Observe the rotation of all “O” rings. Misalignment or excessive length due to stretching may result in the “O” ring “wobbling” or coming off. Misalignment will also cause the “O” ring to wear.
2. Bearings - Listen for any unusual noise that may indicate the need for lubrication or bearing replacement. Only the pillow block bearings can be lubricated. Use general purpose bearing grease meeting NLGI-3 specification.

CAUTION: Do not over lubricate as the grease seals may be damaged. Excessive lubrication can also result in premature bearing failure.

3. Drive Chain and Sprockets - Listen for any unusual noise that may indicate lack of lubrication, misalignment, excessive chain stretch or sprocket failure.
4. Safety Guards - Listen for any noise that may indicate a chain guard or belt guard coming in contact with a chain or belt.

Monthly Maintenance

Perform the following checks with **no power applied to the UniSort IV:**

1. Reducer - Follow reducer manufacturer's instructions for initial oil change.
2. Drive Chain and Sprockets - The UniSort IV single and dual drive units are supplied with an automatic chain oiler. Check for proper oil level in reservoir. Replace with non-detergent SAE 30 oil for above 32° F. operating temperatures. Use SAE 20 non-detergent oil for below 32° F. Ensure re-installation of any removed safety guarding.
3. Drive Pulley Hub - Check tightness of the set screws. Ensure re-installation of any removed safety guarding.
4. Drive Pulley Lagging - Check for any wear or looseness of the drive pulley lagging. Tighten any loose lagging. Replace worn out lagging.

Quarterly - 500 Hours Maintenance

Perform the following checks with **no power applied to the UniSort IV:**

1. Belts and "O" Rings - Check the physical condition of all belts and "O" rings. Clean or replace as necessary.
2. Bearings - Check pillow block bearing mounting bolts for tightness. Lubricate the pillow block bearings using NLGI-3 General Purpose Bearing Grease. Do not over lubricate.
3. Reducer - Follow reducer manufacturer's instructions on correct oil level and frequency of oil changing.
4. Drive Chain and Sprockets - Check for sign of wear and misalignment. Also see weekly and monthly checks.

CAUTION: Ensure safety of personnel while performing these checks.

5. Rollers - Check for any damaged rollers. With the UniSort IV operating, check rollers and pulleys for defective bearings.

Note: Excessive belt tension can shorten the life of the pulley and snub roller bearings.

Semi-Annual; 1000 Hours Maintenance

Perform the following component checks with **no power applied to the UniSort IV:**

Check the overall physical condition of the following:

- All bearings
- Reducer
- Drive Chain and Sprockets
- Drive Pulley Hub
- Drive Motor

Check the drive motor mounting for any loose bolts.

Note: Reinstall any safety guarding that may have been removed to perform these checks.

Belt and O-Ring Replacement for the Diverter Mechanism

The UniSort IV diverter Units are PTO driven from the Main Carrying Belt. Figure H - 1 identifies the various O-rings and Belts used to drive the rollers and pop-up Diverting Wheels. Table H-2 shows a list of belts and O-Rings that are replaceable.

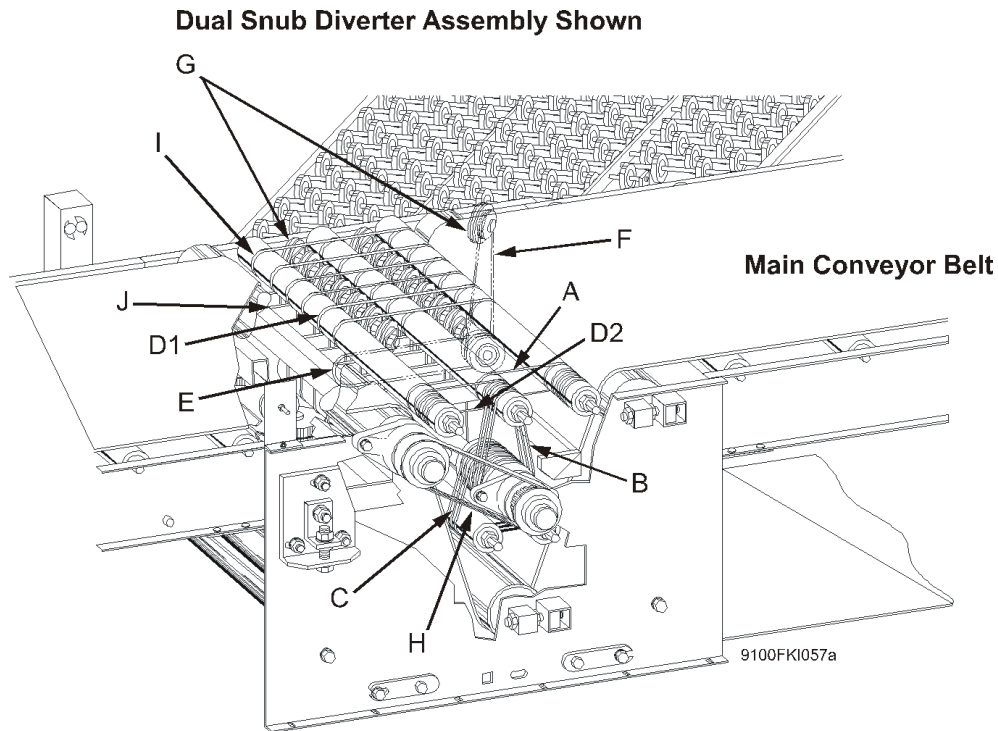

Figure H - 1 O-Rings and Belts that Drive the Rollers and Pop-up Diverting Wheels

Table H-2 Diverter Mechanism Belts

Belt	Size	Material		Use
A	3/16" x 12"	Polyurethane	7883107	Top Aluminum Roller Drive
B	1/4" x 15 3/4"	Polyurethane	7035169	6 Groove Pulley, Drive-Top Middle Roller
C	1/4" x 15 3/4"	Polyurethane	7035169	6 Grv Pulley, Drive-Bottom, Alum. Roller
D1	1/4" x 20 1/2"	Polyurethane	7035168	Drive to First Row Pop-Up Wheels (Clear)
D2	1/4" x 20 1/4"	Polyurethane	7035165	Drive to Second Row Pop-Up Wheels (Orange)
E	1/4" x 20 1/4"	Polyurethane	7035165	Drive to Grooved 2 1/2" Idler Pulley (Orange)
F	1/4" x 20 1/4"	Polyurethane	7035165	Kicker Wheel Drive, O-Ring (Orange)
G	1/4" x 6 1/8"	Polyurethane	7029474	O-Ring on Pop-Up Wheel
H	640-8M-30HTD	Neoprene w/ Nylon Lacing		PTO Drive Belt
I	1/16" x 3/4" x 22 1/2"	Polyurethane	7035167	Aluminum Roller Flat Belts
J	1/16" x 5 3/8"	Polyurethane	7035166	Top Roller Groove, O-Rings

Belt A - 3/16" x12"

The "A" belts connect from the A2 roller to the A1 and A3 rollers. The "A" belts are driven by the "A" roller which is drive by the "B" belts from shaft "BC".

"A" belts can be replaced as follows:

1. Remove the end of the rollers, from the side frame which is nearest the "A" belt to be replaced.
2. Loop the replacement belt over the rollers and slide forward until it falls into the correct groove in the rollers.
3. Re-install the ends of the "A" rollers into the side frame.

Belt B - 1/4" x 15 3/4"

The "B" belts connect from 6 groove pulley(s) on shaft "BC" to roller A2. The "B" belts are also driven by shaft "BC" and drive the center roller A2 which drives the rollers A1 and A2 with the "A" belts.

The "B" belts can be replaced as follows:

1. Remove PTO Belt "H"
2. Remove bearing "BC" (on shaft "BC" from the side frame. The 1 1/2" diameter hole in the side frame will now be exposed. Insert replacement "B" belt(s) through the hole and loop them over around shaft "BC" (see Figure H - 2).
3. Remove the end of the roller shaft A2 form the side frame, then loop the "B" belt(s) up and over the end of the A2 roller shaft.
4. Replace shaft A2 into side frame.
5. Replace bearing "BC" onto side frame.
6. Replace PTO belt H.

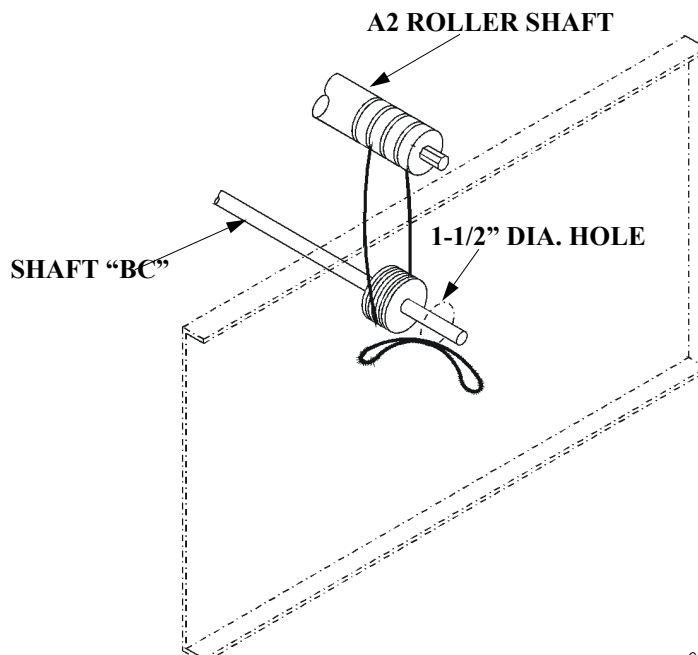

9100FKI058a

Figure H - 2

Belt C - 1/4" x 15 3/4"

The "C" belts connect from 6 groove pulley(s) on shaft "BC" to rollers C1 and C2. rollers C1 and C2 are driven by the "C" belts which are driven by shaft "BC".

Replace "C" belts as follows:

1. Remove bearing "BC" (on shaft "BC" from the side frame).
2. Because belt(s) "C" are on the inner side of belts "B", remove belts "B" from shaft "BC". Pull them out through the hole and over the end of "BC" shaft. Leave them hanging on shaft A2 (see Figure H - 3).

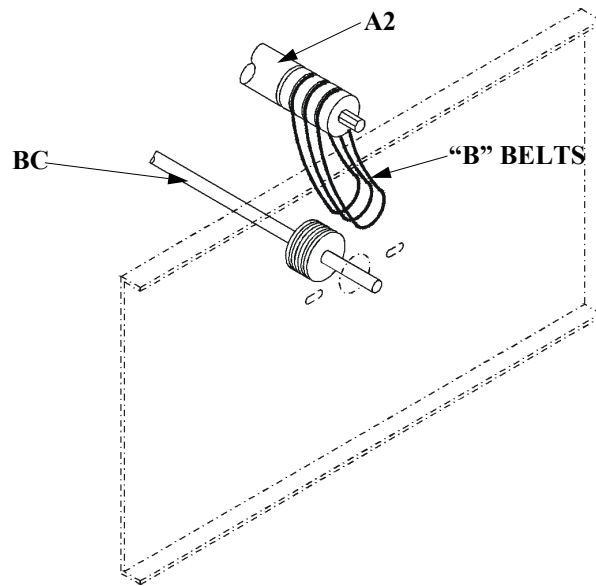

9100FKI059a

Figure H - 3

3. Insert the replacement "C" belts through the 1 1/2" diameter opening in the side frame and loop them over and around shaft "BC" into the proper grooves.
4. Replace the "B" belt(s) hanging on shaft "A" by pulling them down and looping them over and around shaft "BC", slipping them into the proper grooves.
5. Remove the two access plate screws and access plate.
6. Reach through the access opening and disconnect roller C1 from side frame and loop the replacement "C" belt(s) over and around roller C1.
7. Disconnect roller C2 from side frame and loop the replacement "C" belt(s) also over the C2 roller.
8. Replace the end of roller C2 into side frame.
9. Check that "C" belt(s) are properly seated in grooves on shaft "BC".
10. Replace access plate.
11. Replace bearing "BC" and PTO drive belt H.

Belt D1 - 1/4" x 20 1/2"

The "D" belts connect from rollers C1 and C2 to the diverter wheels' smaller diameter in the first row of diverter wheels. (row adjacent to kicker wheel).

Rollers C1 and C2 which are driven by the "C" belts drive the "D" belts which in turn drive the diverter wheels.

Replace the "D" belts as follows:

Note: Work from the side of the side frame opposite the PTO drive belt side.

1. Remove bearing "BC" from the side frame.
2. Remove the two access plate screws and access plate.

Note: Prior to replacing a "D" belt, it is best to move the existing "D" belt(s) to the next inside diverting wheel until the outside diverting wheel is the only one without a belt (see Figure H - 4).

3. Starting with the diverting wheel minus a "D" belt, move each "D" belt, by working them over the diverting wheel and sliding along the C1 and C2 rollers, to the next diverting wheel.

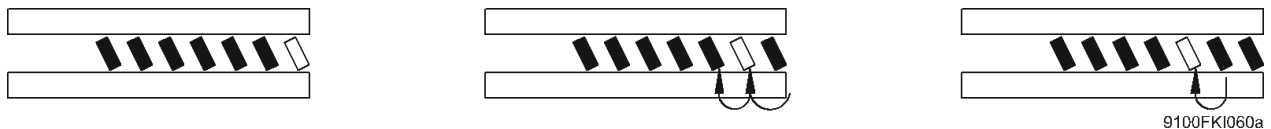

Figure H - 4

4. Working through the access opening, disconnect roller C2 or C1 (depending on which one has a broken or missing belt). Loop the replacement "D" belt over the roller.
5. Replace the end of the roller C1 and C2 into the side frame.
6. Pull the replacement "D" belt up and over the diverting wheel, looping it into the groove on the smaller diameter of the diverting wheel.
7. Replace the access plate.
8. Replace bearing "BC" and PTO drive belt H.

Belt D2 - 1/4" x 20 1/4"

Belts "D2" drives the second row of diverter wheels. A "D2" belt is replaced in the same manner as "D1" belts.

Belt E - 1/4" x 20 1/4"

The "E" belt connects from roller C2 to 2 1/2" idler pulley shaft "D" and is driven by roller C2.

Replace the "E" belt(s) as follows:

1. Remove the two access plate screws and access plate.
2. Reach through the access opening and disconnect roller C2 from the side frame.
3. Loop the replacement "E" belt over the roller.
4. Replace the end of roller C2 into the side frame.
5. Loop the replacement "E" belt over the idler shaft "D" and into the groove on the shaft.
6. Replace the access plate.

Belt F - 1/4" x 20 1/4"

The "F" belt connects from idler shaft "D" to the "kicker" diverting wheel. The "F" belt is driven by the idler shaft "D".

Replace "F" belt as follows:

1. Remove the "E" belt from the idler shaft "D": and let it hang on roller C2.
2. Loop the replacement "F" belt over the idler shaft "D" and pull it up and over into the groove on the smaller diameter of the diverter wheel.
3. Replace the "E" belt into the groove of the idler shaft "D".

Belt G - 1/4" x 6 1/8"

The "G" belt(s) are used in the grooves of the larger diameters of the diverting wheels. When the wheels are in the lowered position, the "G" belts are turning but do not contact the product as it passes over the wheels. When the wheels are in the raised position the "G" belts contact the product diverting it to the take-away conveyor.

Replace "G" belt(s) as follows:

1. Loop the replacement "G" belt over the larger diameter of the diverting wheel and into the groove making sure it is seated all the way around the wheel.

Belt H - 640-8M-30 HTD

The "H" belt is used to provide driving power from the roller shaft bearing AC to roller shaft bearing BC. Replace the belt by sipping it over the two roller shaft bearings and into the bearing grooves.

Belt I - 1/16" x 3/4" x 22 1/2"

The "I" belts connect from the A1 roller, over and under the A2 roller, to the A3 roller. All three rollers drive the "I" belts. The "I" belts help the product span the distance between the rollers when the diverter wheels are in the lowered position.

The "I" belts can be replaced as follows:

Work from the side of the side frame opposite the bearing drive belt side.

Note: Prior to replacing an "I" belt, it is best (and easier) to move the existing "I" belt(s) to the next inside roller groove until the outside roller groove is the only one without an "I" belt (see Figure H - 5).

1. Disconnect rollers A1, A2, and A3 from the side frame.
2. Slip replacement belt over roller ends and into position on the roller.
3. Reconnect rollers A1, A2, and A3 into the side frame.

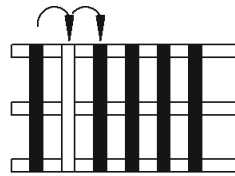
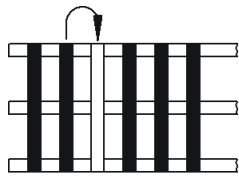

9100FKI061a

Figure H - 5

Belt J - 1/16" x 5 3/8"

The "J" belt(s) are actually O-Rings in grooves on the A1 and A2 rollers under the "I" belts.

To replace, disconnect the "A" roller from the side frame opposite the bearing drive side. Then slide the new "J" belt over the roller and position in the groove under the "I" belt.

Note: After replacing any of the diverting unit O-rings/belts, verify that none have become unseated during replacement procedures.

Adjustments

Mechanical

1. Pop-up sub-frame height.

The pivot arm adjuster is used to assure that the pop-up subframe height is correct when it is in the lowered position. It has been pre-adjusted at the factory and should need no further adjustment. If adjustment should be required; re-adjust as shown in Figure H - 6.

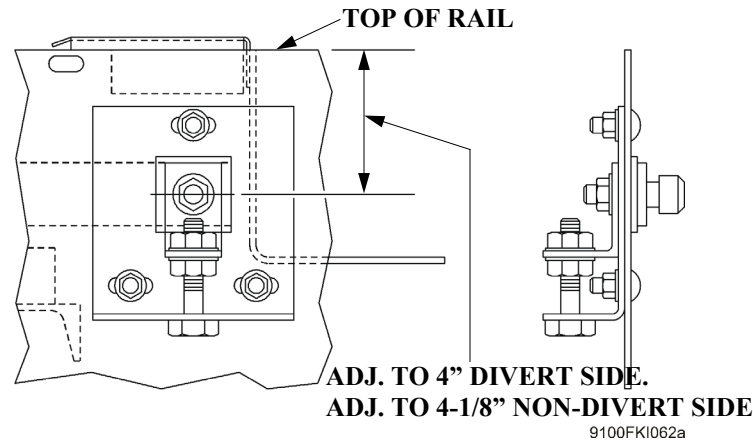

Figure H - 6

2. Motor drive sprocket chain.

Single Drive Units

Motor drive sprocket chain: Adjust for 3/8" slack at chain midpoint by moving the motor with adjustment screws (see Figure H - 7). (Also see decal inside chain guard.)

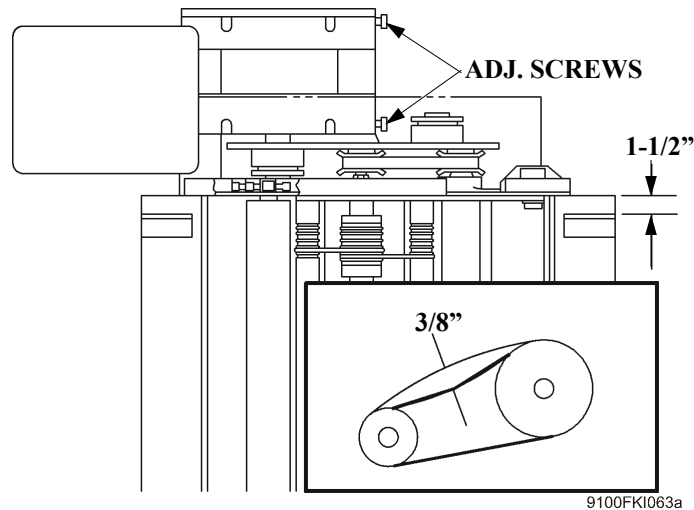
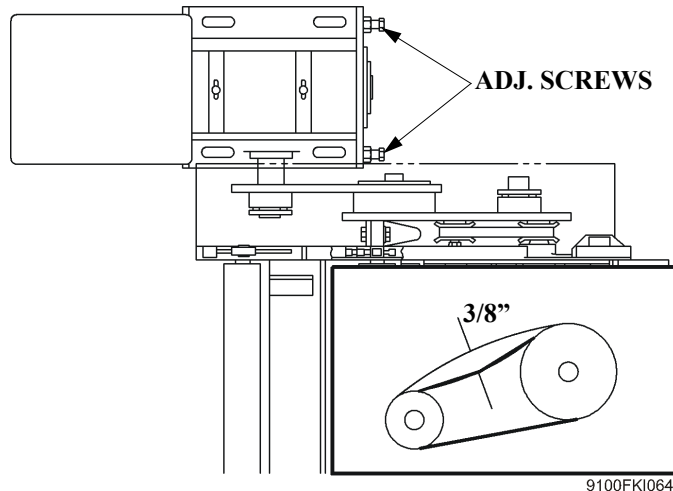

Figure H - 7

Dual Drive Units

Motor drive sprocket chain: Adjust for 3/8" total slack at chain midpoint by moving the motor with adjustment screws (see Figure H - 8).

Adjust secondary chain by raising or lower chain tensioner (see Figure H - 9). (Also see decal inside chain guard.)



9100FK1064a

Figure H - 8

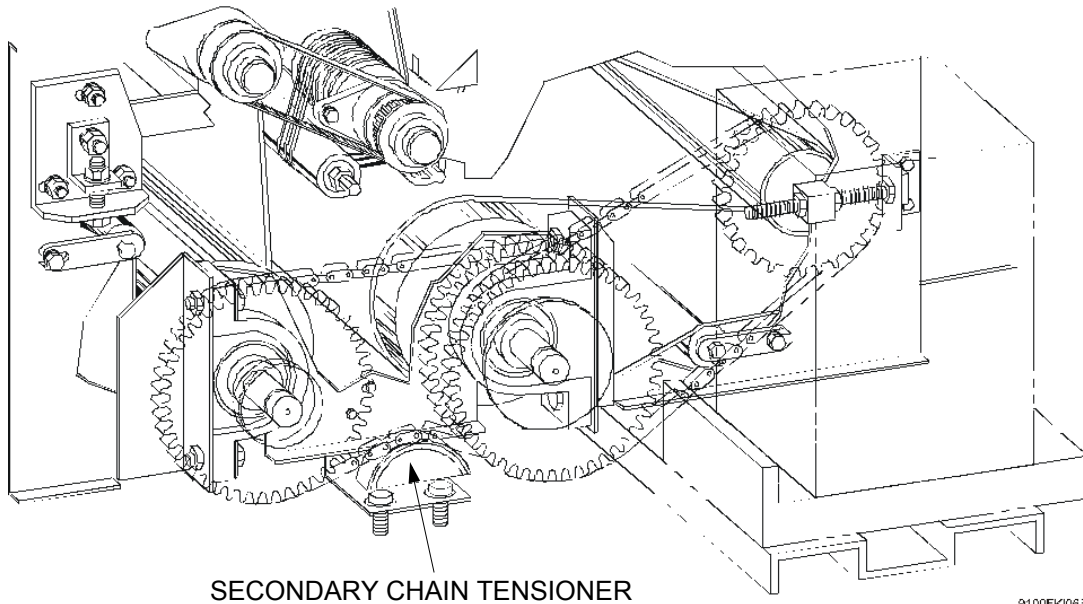

9100FK1065a

Figure H - 9

Troubleshooting Belt Problems

The following table provides guidelines in remedying belt problems. Always check belt tracking adjustments after adjusting or changing any pulleys or snub rollers.

Table H-3 Basic Belt Troubleshooting Problems and Solutions

Problem	Cause	Solution
Belt stretches excessively.	Too much positive take-up force/ belt tension.	Perform tension adjustments.
One part of belt creeps to one side.	Belt ends are not joined squarely due to the belt ends not being cut square at the joints.	Replace with new size fasteners after cutting the belt ends perfectly square using a T-square.
Entire belt creeps to one side.	Belt shifts to low side. The base structure or conveyor frame is not level or is crooked.	Stretch a string along the edge of the frame, check alignment of frame and correct. Then check the level of supporting structure.
	Alignment of pulleys, drives, tail, idlers, or snub rollers are not per- pendicular or out-of-line with center line of conveyor.	Use a T-square against the edge of the conveyor and pulleys or idlers to recheck and square the pulleys. Re-check belt tracking adjust- ments.
Belt creeps to one side in the infeed area.	Infeed end pulley is out-of-line.	First, adjust snub roller. Second, realign infeed end pulley by advancing (belt travel direction) the end of the pulley or idler to which the belt has shifted.
Belt creeps to one side in the dis- charge end area.	Discharge end pulley is out-of-line (not perpendicular with center line of the conveyor).	First, adjust snub roller. Second, realign infeed end pulley by advancing (return belt travel direc- tion) the end of the pulley or idler to which the belt has shifted.
Belt wanders irregularly	The conveyor is over-belted. This results in the belt being too stiff to properly operate over the pulley diameters.	Change to the proper belt or use pulleys with larger diameters.
	Off center or improper loading.	Correct loading procedure.
Belt fasteners pulling out.	Fasteners are incorrect size.	Re-lace belt with proper size fasteners.
	Too much tension on belt.	Relieve tension until belt will run without slipping on the drive pulley.
	Pulley diameters too small for the thickness of belt used.	Replace with larger diameter pulleys; or thinner belt if practical.

Problem	Cause	Solution
Edge wear is excessive.	Belts edges fold up on conveyor guards, frame, kicker wheel	Remove the rough areas on conveyor guards or frame. Check belt tracking.
	Belt shifts to opposite side and rubs excessively due to side loading.	Loading in direction of belt travel will improve this condition.

SECTION I: PARTS IDENTIFICATION

General Information

The purpose of this section is to provide a list of common spare parts for a preventive maintenance program and also to minimize the chances for extended DOWNTIME.

The following pages illustrate the location of these recommended spare parts as they apply to each particular unit. Keep in mind that these illustrations apply to the STANDARD product line and to project specific parts. These items will show up on the Bill of Material as a “coded” item. For example: there will also be items on the Bill of Material such as gearmotors, sprockets, chain, etc., that will also show up on the price sheets.

Diverter Unit

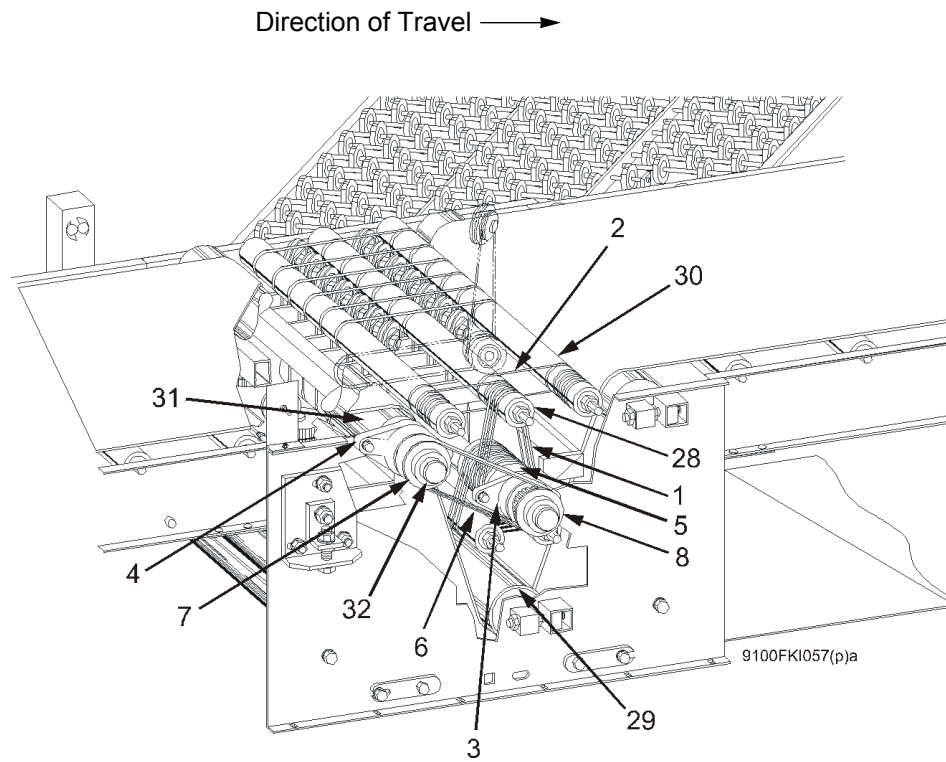
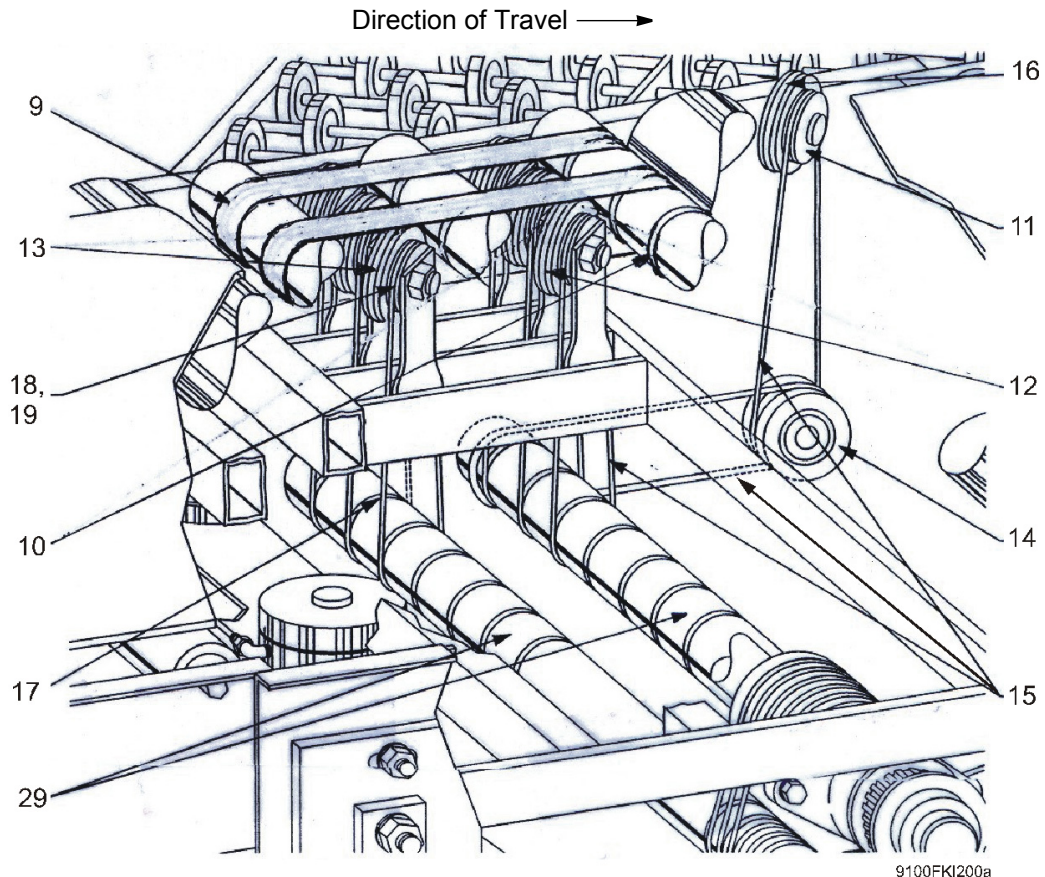

Figure I - 1 Diverter Unit, Outer Parts, (Dual Snub Diverter Shown)



9100FKI200a

Figure I - 2 Diverter Unit, Inner Parts, (Dual Snub Diverter Shown)

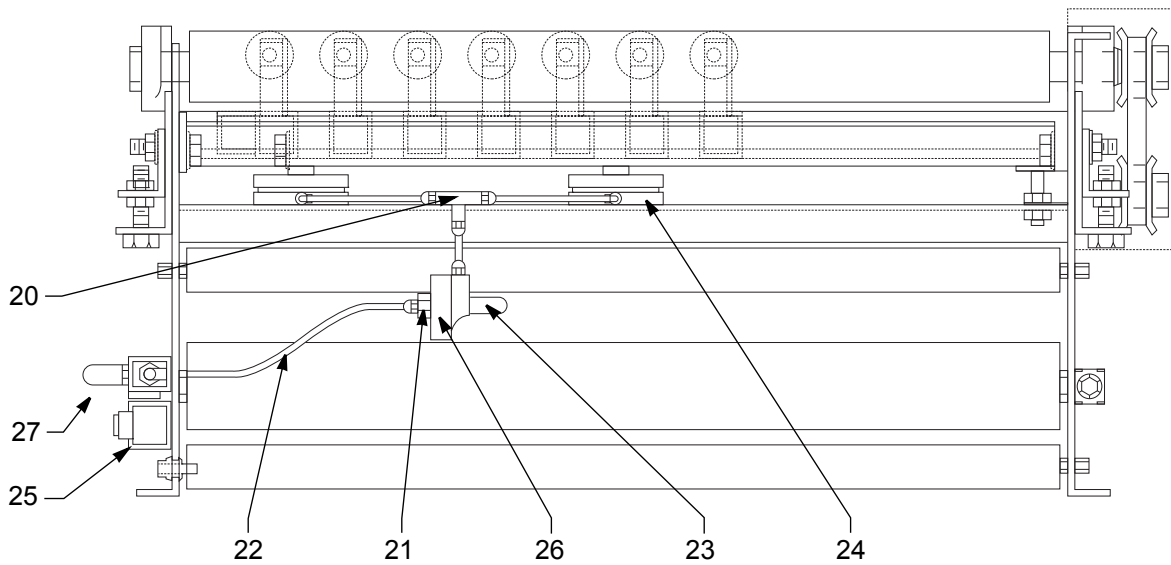

Figure I - 3 Diverter Unit, Pneumatic Components, (Dual Snub Diverter Shown)

Diverter Spare Parts, Non-width Related

Key #	Part Description	Part Number
1	Polyurethane Belt 1/4" x 15-3/4"	7035169
2	Polyurethane Belt 3/16" x 12"	7883107
3	Flange Bearing, 2-Bolt 1" Bore	7010490
4	Flange Bearing, 2 Bolt, 1-3/16" Bore	7060572
5	MSS Drum Pulley	685000
6	HTD Timing Belt 640-8M-30	759510
7	Timing Belt Sprocket, 1 3/16" Bore	PS549507
8	Timing Belt Sprocket, 1" Bore	PS549508
9	Urethane Belt 22 1/2" x 3/4" x 1/16"	7035167
10	Polyurethane O-Ring 1/16" x 5-3/8"	7035166
11	MSS Diverter Wheel Assembly, 01 A=1.125", (Kicker, Row 3)	000905
12	MSS Diverter Wheel Assembly, 02 A=1.271", (Large Groove, Row 2)	000906
13	MSS Diverter Wheel Assembly, 03 A=1.462", (Small Groove, Row 1)	000907
14	MSS Diverter Id Hub Assembly 2-1/2"x2"LG	000919
15	Polyurethane O-Ring 1/4" x 20-1/4", 83A, (Orange, Row 2 and Row 3)	7035165
16	Polyurethane O-Ring 1/4" x 6-1/8"	7029474
17	Polyurethane O-Ring 1/4" x 20-1/2" (Clear, Row 1)	7035168
18	Unisort Washer, 1.115 od x 5/8"	000513
19	Diverter Wheel Axle, Plated	000904
20	Tee, Union, 3/8" Tube, Push To	7536413
21	Straight Connector 3/8T x 1/4MPT	7060508
22	3/8" od Flexible Hipress Tubing	7060509
23	Silencer, 1/4MPT Allied Witan	7060583
24	Actuator, Pancake Cylinder, 3"BR X .313ST MSS	7023944
25	Valve, 3-way, Alkon PMC1SS115/60	7060505
26	Quick Exhaust Valve, 1/4" Pipe	7035554
27	Silencer 1/8MPT	271781
27a	Bearing Assy. ASQ6205 Wolverine (251) Single & Dual Drive (Not Shown)	7106205
27b	Connecting Links RC-80 (Dual Drive) (Not Shown)	7311080

Diverter Spare Parts Width Related (Conveyor Width)

Key #	Part Description	Part Number by Conveyor Width			
		18"	24"	30"	36"
28	MSS Grooved Roller, ABEC	509957	509958	509959	509960
29	MSS Drive Roller Assembly Bottom ABEC	509949	509950	509951	509952
30	MSS Grooved Drive Roller, ABEC	509953	509954	509955	509956
31	MSS PTO Pulley, 3" CFX 1 3/16	685011	685012	685013	685014
32	MSS Drum Shaft, 1" dia	695001	695002	695003	695004
32a*	Roller (Not Shown)				
	RLR G196 A1 P 01 __. __ NC	7504895	7504834	7504843	7504852

(*) See Roller Description Explanation on page I-10

Diverter Belt Rollers

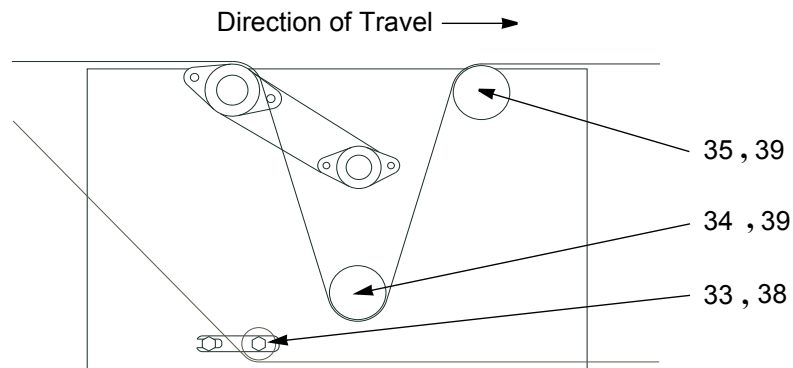

Figure I - 4 End Diverter (Front View)

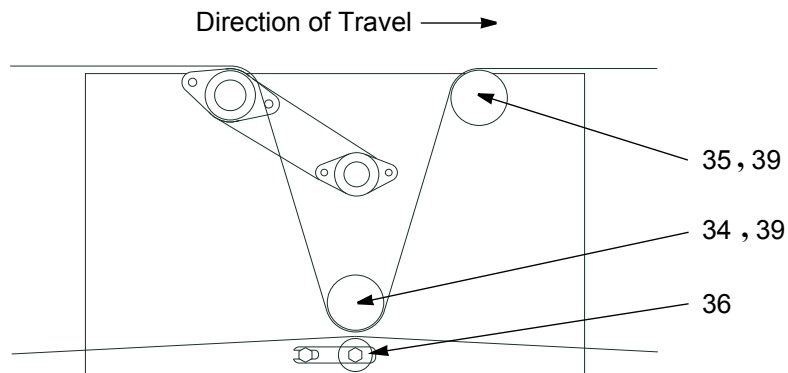

Figure I - 5 Intermediate Diverter (Front View)

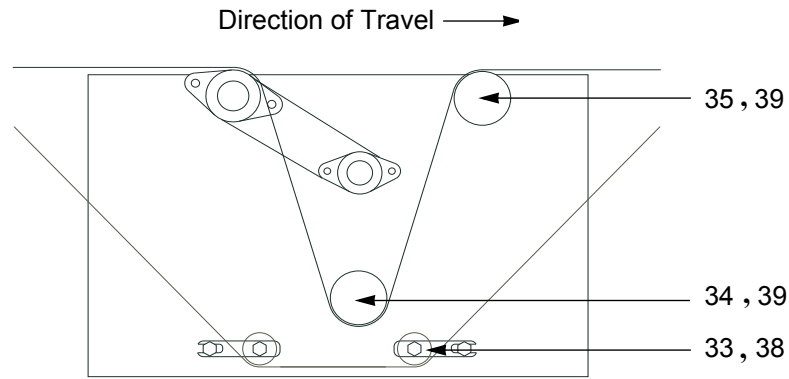

Figure I - 6 Dual Snub Roller Diverter (Front View)

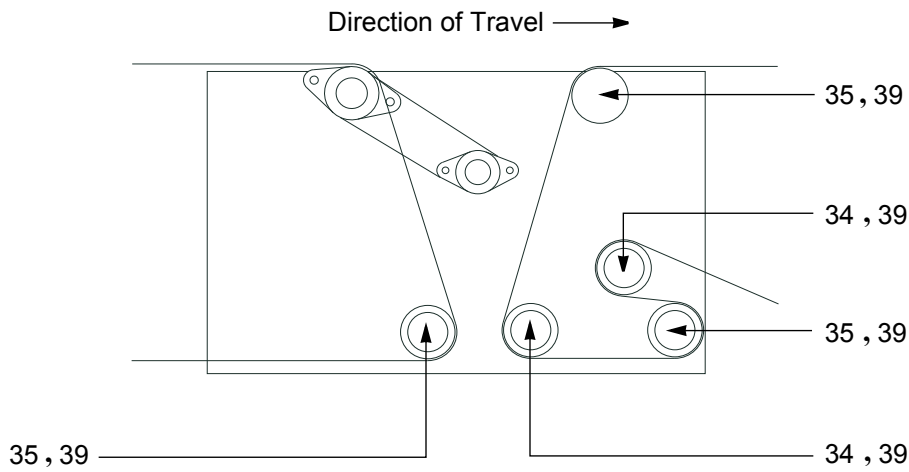

Figure I - 7 Interface Diverter with Take-Up & Idler Rollers (Front View)

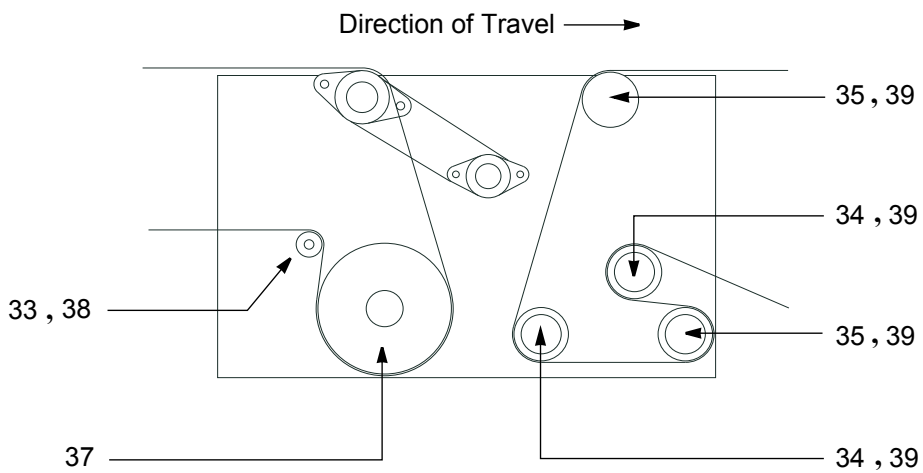

Figure I - 8 Single Drive Diverter (Front View)

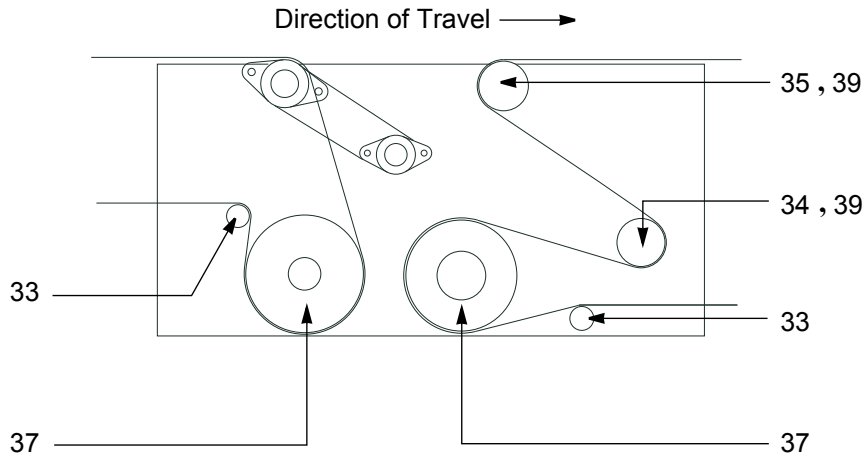

Figure I - 9 Dual Drive Diverter (Front View)

Diverter Belt Roller Parts, Width Related

Table I - 1 – Diverter Spare Parts, Non-width Related

Key #	Part Description	Part Number by Conveyor Width			
		18"	24"	30"	36"
33	Roller G251AB BX-	501025	501026	501027	501028
34	Idler Roller 3-1/2FF	501223	501224	501225	501226
35	Idler Roller 3 1/2CF	501227	501228	501229	501230
36*	Roller (Not Shown)				
	RLR G196 A1 P 01 __. __ NC	7504895	7504834	7504843	7504852
37	Drive Pulley & Shaft, CF	682601	682602	682603	682604
38	Axle, 11/16, Tapped Ends	501140	501141	501142	501143
38a	Idler Roller 3-1/2FF	501223	501224	501225	501226

(*) See Roller Description Explanation on page I-10.

Diverter Belt Roller Parts, Non-width Related

Table I.1 – Diverter Belt Roller Parts, Non-width Related

Key #	Part Description	Part Number
39	Bearing, 3 1/2" Takeup/Idler Roller, 1 1/8" SQ	7350360
39a	Flat Adj Ret Roller 1 x 1/8 x 4 3/8 (not shown)	7030020

Parts Not Illustrated

The following parts do not appear in the illustrations.

Key #	Part Description	Part Number
	Bumper Rubber FB-4444	7885294
	Single Gang Remote Bracket	000502
	Even-flo Applicator Brush	000503
	Oiler Reservoir LDI	000890

Nondivert Sorter Modules

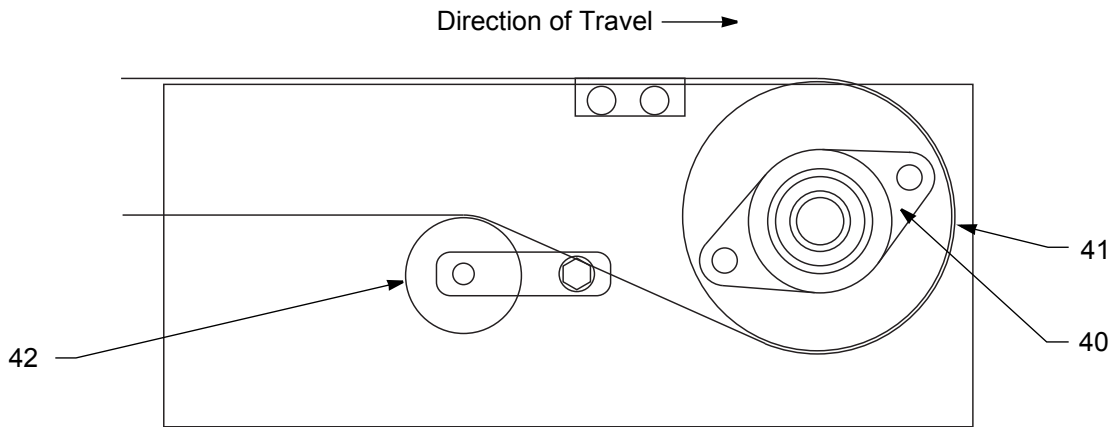

Figure I - 2 End Drive (No Drive Unit)

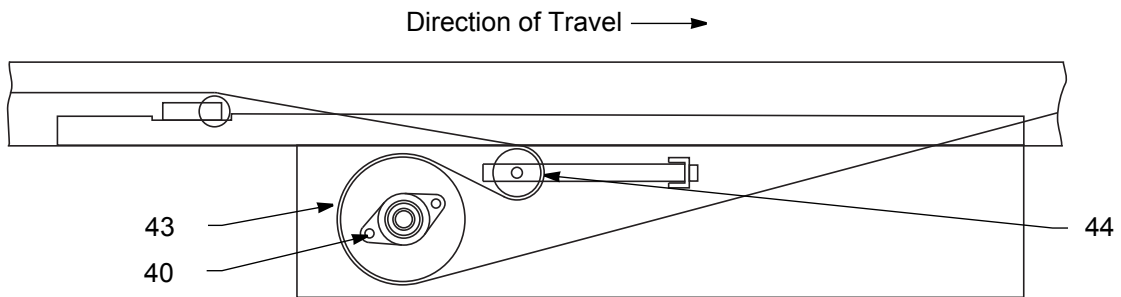

Figure I - 3 Center Drive (No Drive Unit)

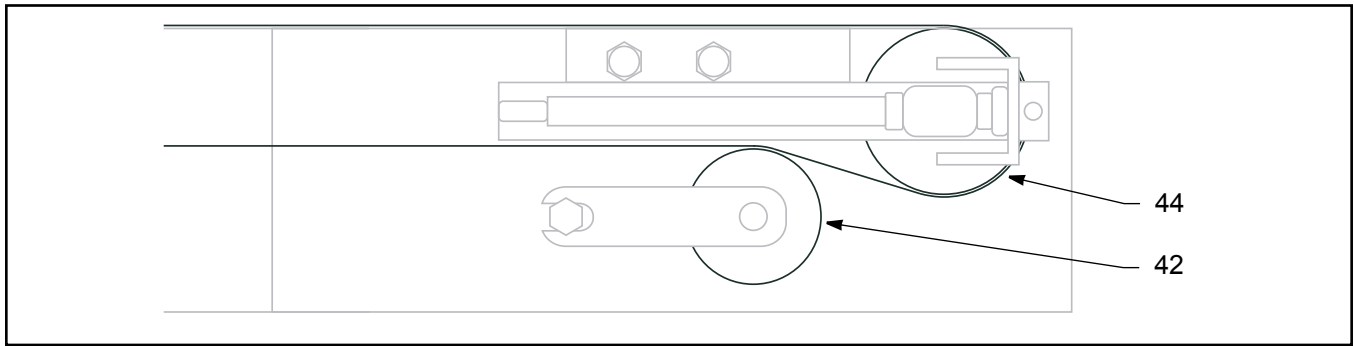

Figure I - 4 End Idler

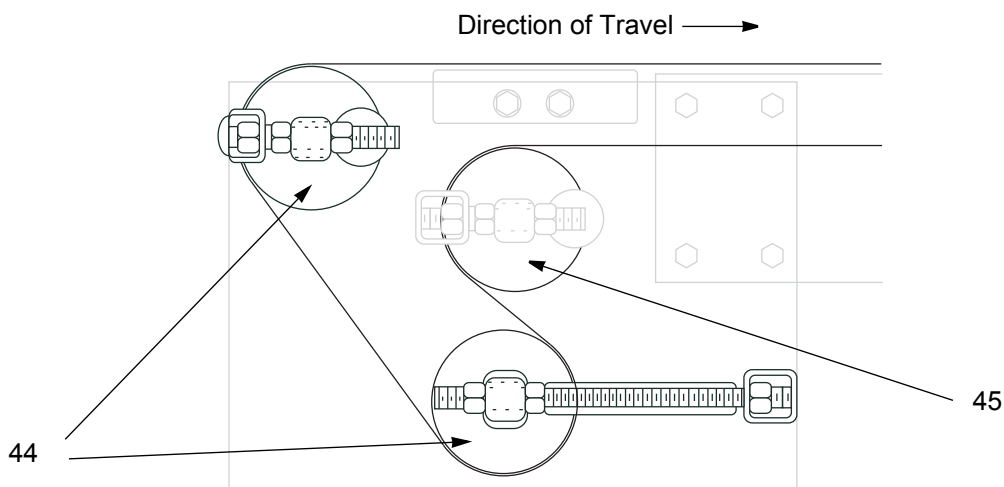

Figure I - 5 End Take-Up

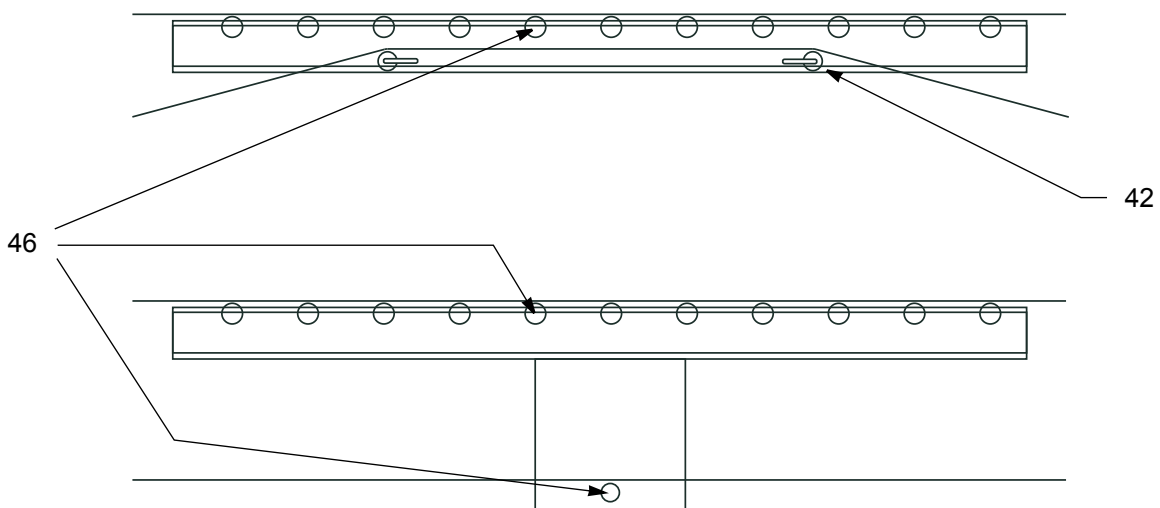

Figure I - 6 Intermediate Sections

Table I - 7 – Nondivert Module Spare Parts (Non-width Related)

Key #	Part Description	ParNumber
40	Flange Bearing 1-7/16" D. Bore	7001757

Table I - 8 – Nondivert Module Spare Parts (Width Related)

Key #	Part Description	Part Number by Belt Width			
		15"	21"	27"	33"
41	Drive Pulley	680519	680520	680521	680524
42	Snub Roller	502474	502475	502476	502466
43	Drive Pulley	681360	680522	680523	680524
44	Take-up Roller 3-1/2" CF, 1-1/8" SQ	501216	501217	501218	501219
45	Snub Roller 3-1/2" CF, 1-1/8" SQ	501321	501322	501323	501324
46*	Roller				
	RLR G196 A1 P 01 __. __ NC	7504822	7504830	7504838	7504849
	RLR G196 GH P01 __. __ NC	7496310	7496413	7496510	7496588

(*) See Roller Description Explanation

(Example) RLR G196 GH P 01 15.00 NC

RLR = Roller
 G = (Roller Tube Material/Finish) Galvanized Steel
 196 = (Roller Tube) 1.90" dia x 16 gage (.065" wall)
 A1 = (Bearing Type) ABEC Precision Bearing
 P = Plain Steel Axle
 01 = Spring-Loaded Axle; Fixed Roller w/o Grooves
 15.00 = Conveyor Width "W"
 NC = No Cover

Drive Components

The drive for a Unisort IV sorter may be located at a diverter unit or at another location, such as an end drive or a center drive.

Drives Located at a Diverter Unit

The configuration of a drive located at a diverter unit may be either single drive or dual drive. Drive components vary according to drive configuration, motor horsepower and sorter speed. Drive components are presented with a figure and table for each combination of drive configuration and motor horsepower, in the following order:

Single Drive

- 1 Horsepower
- 1.5 Horsepower
- 2 Horsepower
- 3 Horsepower
- 5 Horsepower
- 7.5 Horsepower

Dual Drive

- 2 Horsepower
- 3 Horsepower
- 5 Horsepower
- 7.5 Horsepower
- 10 Horsepower
- 15 Horsepower

Drives at Other Locations

Spare parts for drives at locations other than at the diverter unit are documented in the product manual *CS8100, Powered Belt*, in Section I, "Spare Parts."

Single Drive, 1 Horsepower

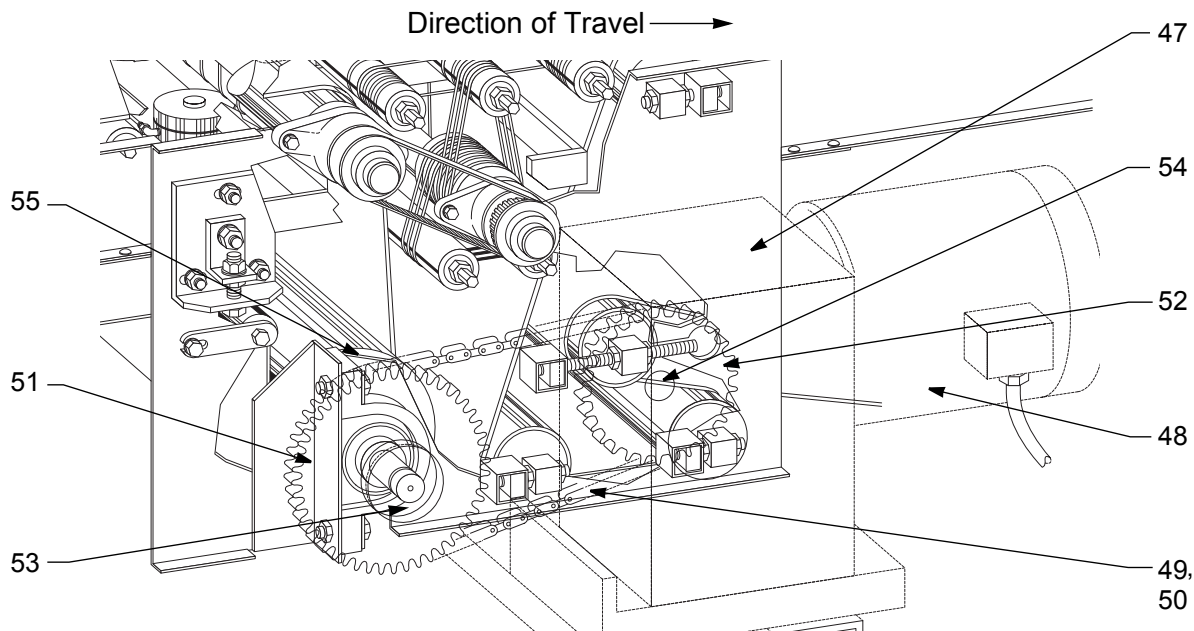

Figure I - 9 Drive Assembly, Single Drive Diverter

Single Drive Diverter (RH & LH), 1 Horsepower

Key #	Part Description	Speed (FPM)				
		150	180	220	250	300
47	Gear Reducer (Right Hand)	811246	811204	811204	811202	811202
	Gear Reducer (Left Hand)	811245	811203	811203	811201	811201
48	Motor	330707	330707	330707	330707	330707
49	Chain	200987	200987	200987	200987	200987
50	Chain Coupler	7311060	7311060	7311060	7311060	7311060
51	Sprocket (Driven)	745644 (24tooth)	745644 (24tooth)	745644 (24tooth)	745644 (24tooth)	745644 (24tooth)
52	Sprocket (Driver)	745639 (19tooth)	745637 (17tooth)	745641 (21tooth)	745636 (16tooth)	745639 (19tooth)
53	Hub (for Driven Sprocket)	230782& 7758291	230782& 7758291	230782& 7758291	230782& 7758291	230782& 7758291
54	Hub (for Driver Sprocket)	230946	230946	230976	230946	230946
55	Pillow Block	400330	400330	400330	400330	400330

Single Drive, 1.5 Horsepower

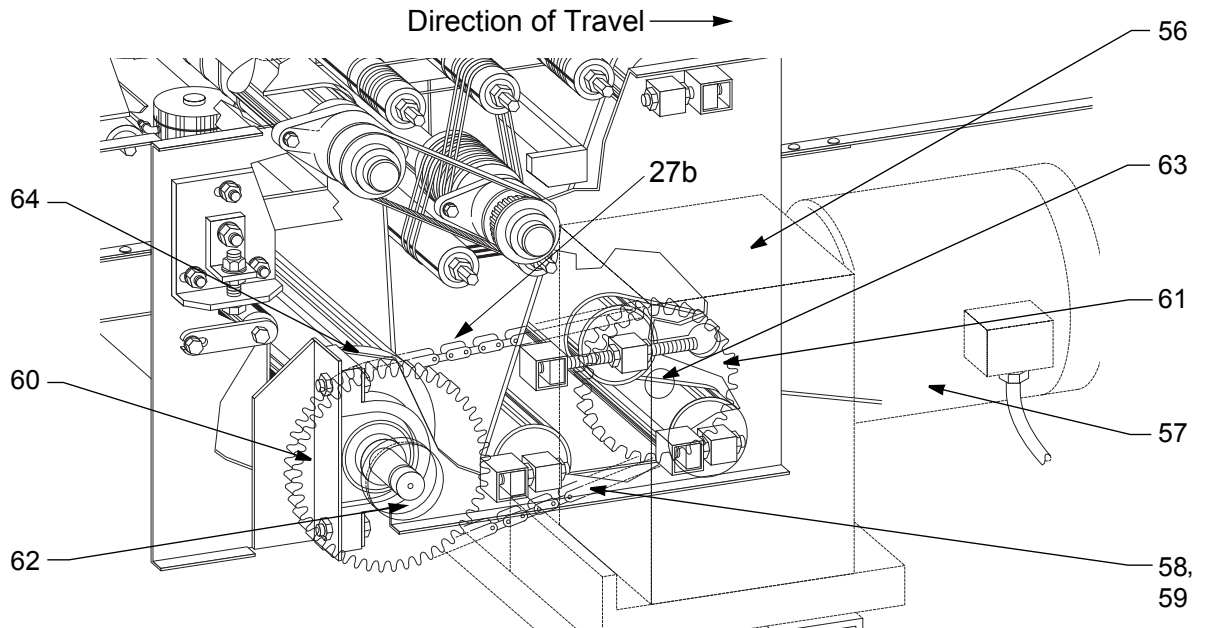

Figure I - 10 Drive Assembly, Single Drive Diverter

Table I - 11 – Single Drive Diverter (RH & LH), 1.5 Horsepower

Key #	Part Description	Speed (FPM)				
		150	180	220	250	300
56	Gear Reducer (Right Hand)	811208	811206	811206	811202	811202
	Gear Reducer (Left Hand)	811207	811205	811205	811201	811201
57	Motor	330709	330709	330709	330709	330709
58	Chain	200987	200987	200987	200987	200987
59	Chain Coupler	7311060	7311060	7311060	7311060	7311060
60	Sprocket (Driven)	745644 (24tooth)	745644 (24tooth)	745644 (24tooth)	745644 (24tooth)	745644 (24tooth)
61	Sprocket (Driver)	745639 (19tooth)	745637 (17tooth)	745641 (21tooth)	745636 (16tooth)	745639 (19tooth)
62	Hub (for Driven Sprocket)	230782& 7758291	230782& 7758291	230782& 7758291	230782& 7758291	230782& 7758291
63	Hub (for Driver Sprocket)	230752	230752	230784	230946	230946
64	Pillow Block	400330	400330	400330	400330	400330

Single Drive, 2 Horsepower

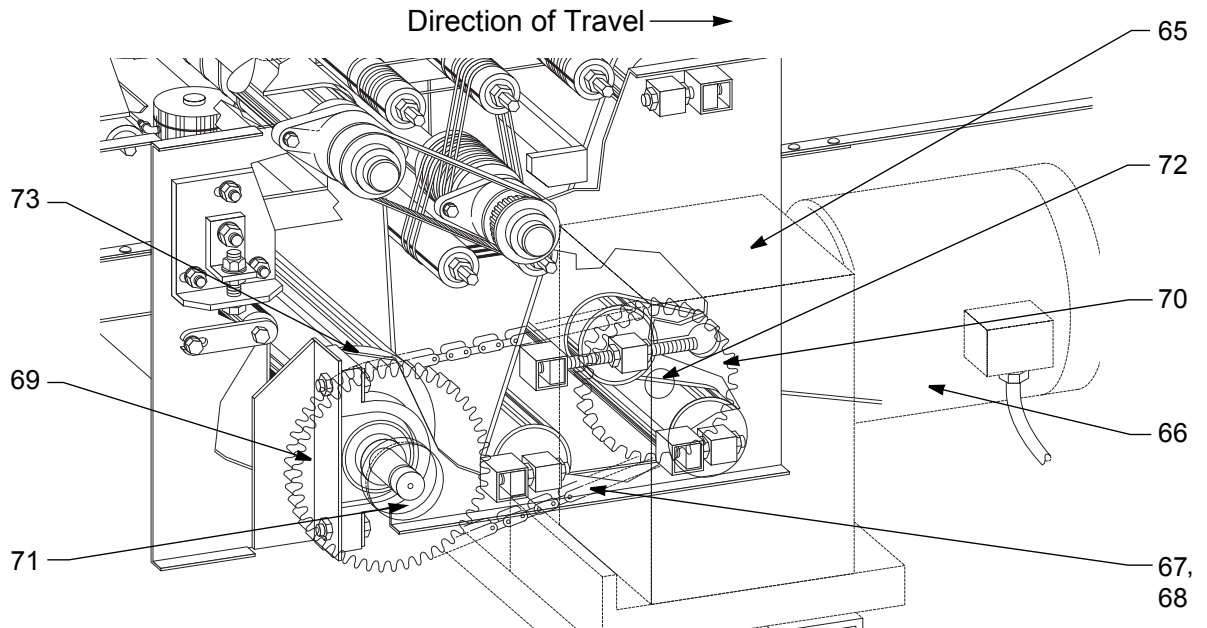

Figure I - 12 – Drive Assembly, Single Drive Diverter

Table I - 13 – Single Drive Diverter (RH & LH), 2 Horsepower

Key #	Part Description	Speed (FPM)				
		150	180	220	250	300
65	Gear Reducer (Right Hand)	811214	811248	811248	811210	811210
	Gear Reducer (Left Hand)	811213	811247	811247	811209	811209
66	Motor	330711	330711	330711	330711	330711
67	Chain	200987	200987	200987	200987	200987
68	Chain Coupler	7311060	7311060	7311060	7311060	7311060
69	Sprocket (Driven)	745644 (24tooth)	745644 (24tooth)	745644 (24tooth)	745644 (24tooth)	745644 (24tooth)
70	Sprocket (Driver)	745639 (19tooth)	745637 (17tooth)	745641 (2tooth)	745636 (16tooth)	745639 (19tooth)
71	Hub (for Driven Sprocket)	230782& 7758291	230782& 7758291	230782& 7758291	230782& 7758291	230782& 7758291
72	Hub (for Driver Sprocket)	2155220	2155220	230780	230752	230752
73	Pillow Block	400330	400330	400330	400330	400330

Single Drive, 3 Horsepower

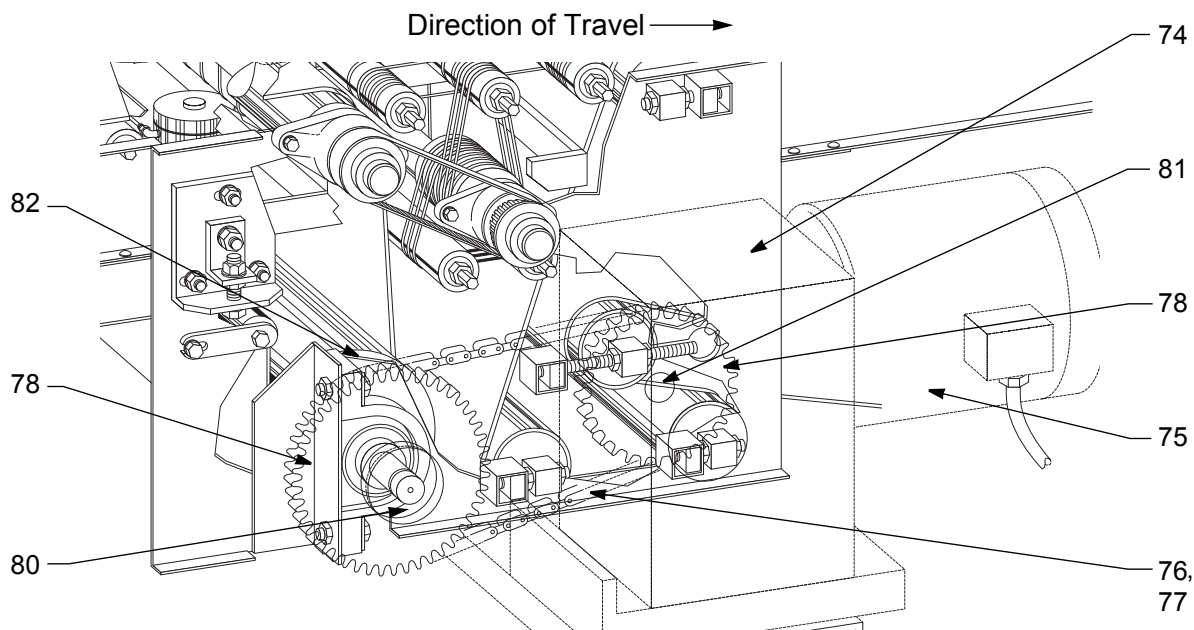

Figure I - 14 – Drive Assembly, Single Drive Diverter

Table I - 15 – Single Drive Diverter (RH & LH), 3 Horsepower

Key #	Part Description	Speed (FPM)				
		150	180	220	250	300
74	Gear Reducer (Right Hand)	811222	811218	811218	811250	811250
	Gear Reducer (Left Hand)	811221	811217	811217	811249	811249
75	Motor	330713	330713	330713	330713	330713
76	Chain	200987	200987	200987	200987	200987
77	Chain Coupler	7311060	7311060	7311060	7311060	7311060
78	Sprocket (Driven)	745644 (24tooth)	745644 (24tooth)	745644 (24tooth)	745644 (24tooth)	745644 (24tooth)
79	Sprocket (Driver)	745639 (19tooth)	745637 (17tooth)	745641 (2tooth)	745636 (16tooth)	745639 (19tooth)
80	Hub (for Driven Sprocket)	230782& 7758291	230782& 7758291	230782& 7758291	230782& 7758291	230782& 7758291
81	Hub (for Driver Sprocket)	230953	2155220	230780	230752	230752
82	Pillow Block	400330	400330	400330	400330	400330

Single Drive, 5 Horsepower

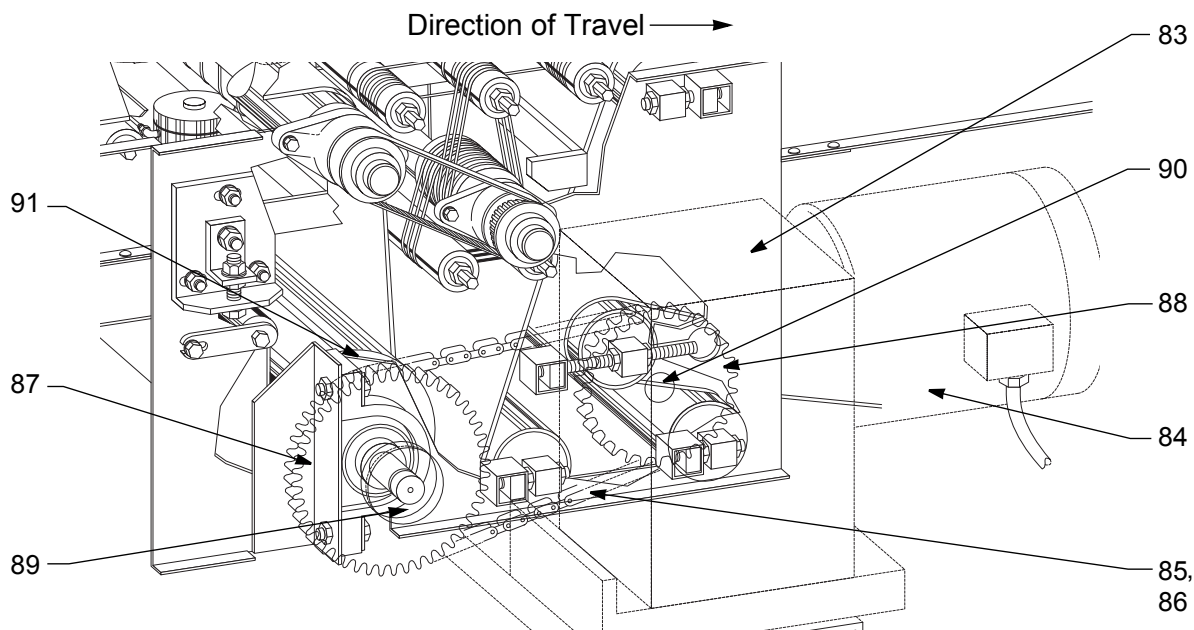

Figure I - 16 – Drive Assembly, Single Drive Diverter

Table I - 17 – Single Drive Diverter (RH & LH), 5 Horsepower

Key #	Part Description	Speed (FPM)				
		150	180	220	250	300
83	Gear Reducer (Right Hand)	811230	811228	811228	811224	811224
	Gear Reducer (Left Hand)	811229	811227	811227	811223	811223
84	Motor	330715	330715	330715	330715	330715 (330721 RH)
85	Chain	200987	200987	200987	200987	200987
86	Chain Coupler	7311060	7311060	7311060	7311060	7311060
87	Sprocket (Driven)	745644 (24tooth)	745644 (24tooth)	745644 (24tooth)	745644 (24tooth)	745644 (24tooth)
88	Sprocket (Driver)	745639 (19tooth)	745637 (17tooth)	745641 (21tooth)	745636 (16tooth)	745639 (19tooth)
89	Hub (for Driven Sprocket)	230782& 7758291	230782& 7758291	230782& 7758291	230782& 7758291	230782& 7758291
90	Hub (for Driver Sprocket)	230951	230951	230987	230953	230953
91	Pillow Block	400330	400330	400330	400330	400330

Single Drive, 7.5 Horsepower

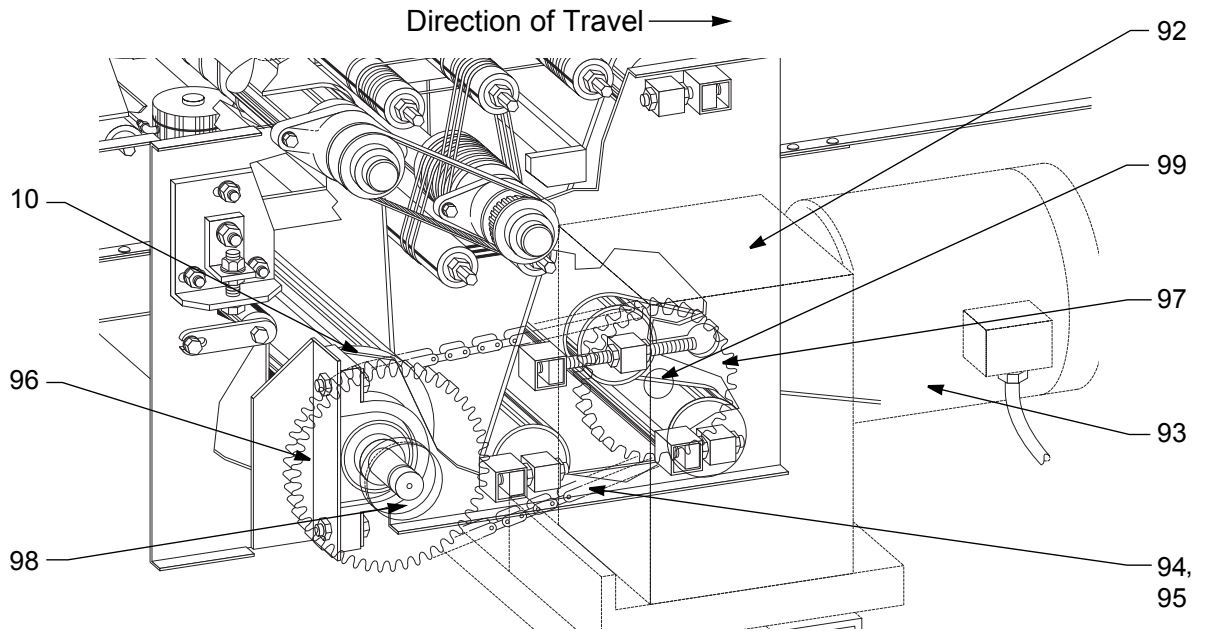

Figure I - 18 – Drive Assembly, Single Drive Diverter

Table I - 19 – Single Drive Diverter (RH & LH), 7.5 Horsepower

Key #	Part Description	Speed (FPM)				
		150	180	220	250	300
92	Gear Reducer (Right Hand)	–	–	811234	811232	811232
	Gear Reducer (Left Hand)	–	–	811233	811231	811231
93	Motor	–	–	330721	330721	330721
94	Chain	–	–	200987	200987	200987
95	Chain Coupler	–	–	7311060	7311060	7311060
96	Sprocket (Driven)	–	–	745644 (24tooth)	745644 (24tooth)	745644 (24tooth)
97	Sprocket (Driver)	–	–	745641 (2tooth)	745636 (16tooth)	745639 (19tooth)
98	Hub (for Driven Sprocket)	–	–	230782& 7758291	230782& 7758291	230782& 7758291
99	Hub (for Driver Sprocket)	–	–	230786	230951	230951
100	Pillow Block	–	–	400330	400330	400330

Dual Drive, 2 Horsepower

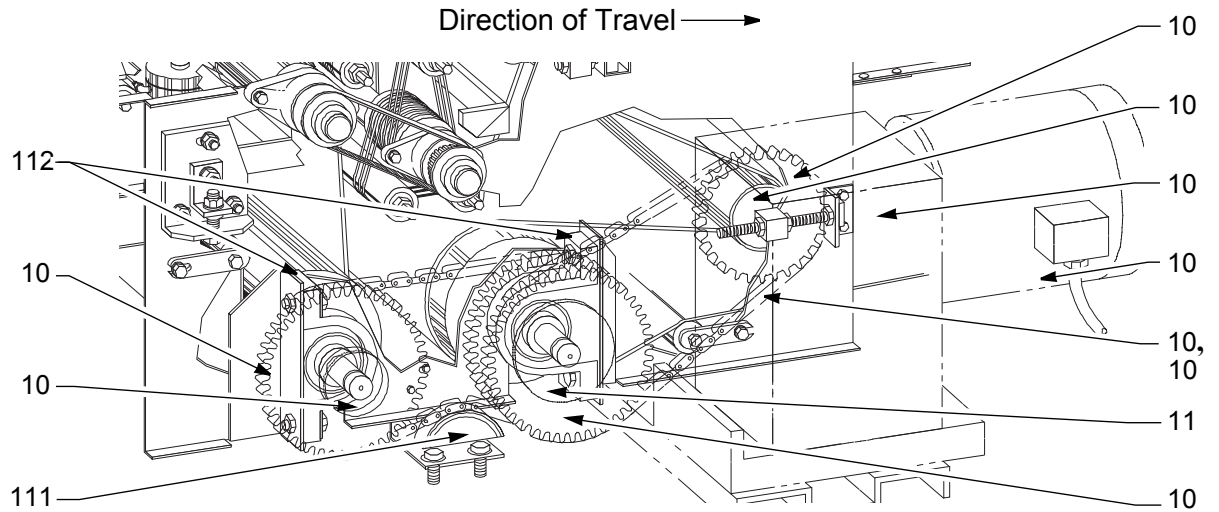

Figure I - 20 – Drive Assembly, Dual Drive Diverter

Table I - 21 – Dual Drive Diverter (RH & LH), 2 Horsepower

Key #	Part Description	Speed (FPM)				
		150	180	220	250	300
101	Gear Reducer (Right Hand)	811214	811248	811214	811210	811210
	Gear Reducer (Left Hand)	811213	811247	811247	811209	811209
102	Motor	330711	330711	330711	330711	330711
103	Chain	200987	200987	200987	200987	200987
104	Chain Coupler	7311060	7311060	7311060	7311060	7311060
105	Sprocket (PTO)	745644 (24tooth)	745644 (24tooth)	745644 (24tooth)	745644 (24tooth)	745644 (24tooth)
106	Sprocket (Driver)	745639 (19tooth)	745637 (17tooth)	745641 (21tooth)	745636 (16tooth)	745639 (19tooth)
107	Sprocket (Double)	749552 (24tooth)	749552 (24tooth)	749552 (24tooth)	749552 (24tooth)	749552 (24tooth)
108	Hub (for PTO Sprocket)	230782& 7758291	230782& 7758291	230782& 7758291	230782& 7758291	230782& 7758291
109	Hub (for Driver Sprocket)	2155220	230752	230784	230752	230752
110	Hub (for Double Sprocket)	230793	230793	230793	230793	230793
111	Chain Tensioner	201121	201121	201121	201121	201121
112	SMC Pillow Block	400335	400335	400335	400335	400335

Dual Drive, 3 Horsepower

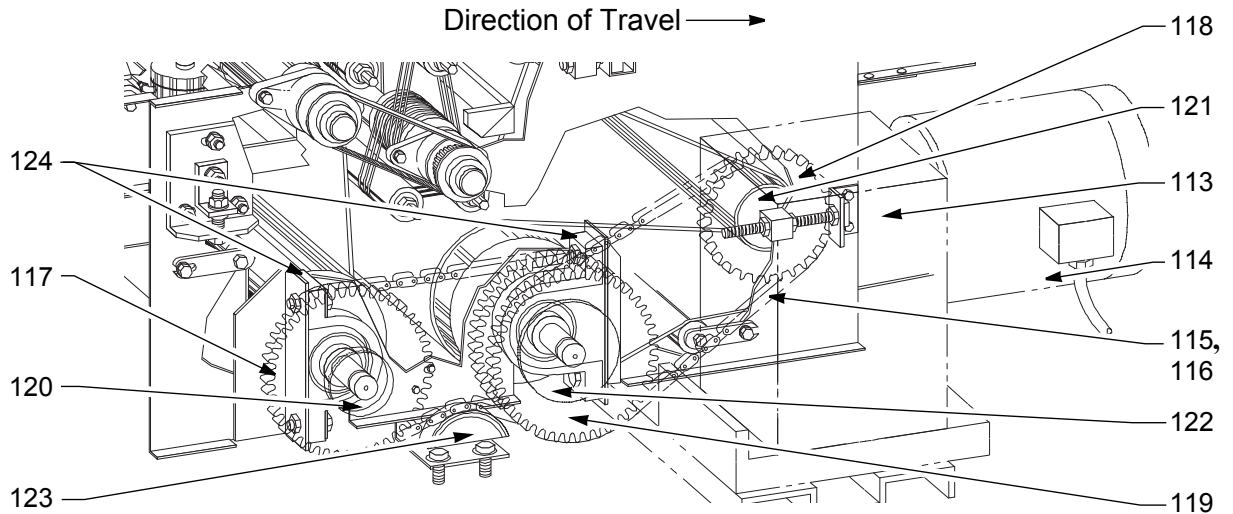

Figure I - 22 – Drive Assembly, Dual Drive Diverter

Table I - 23 – Dual Drive Diverter (RH & LH), 3 Horsepower

Key #	Part Description	Speed (FPM)				
		150	180	220	250	300
113	Gear Reducer (Right Hand)	811222	811218	811218	811247	811250
	Gear Reducer (Left Hand)	811221	811217	811217	811249	811249
114	Motor	330713	330713	330713	330713	330713
115	Chain	200987	200987	200987	200987	200987
116	Chain Coupler	7311060	7311060	7311060	7311060	7311060
117	Sprocket (PTO)	745644 (24tooth)	745644 (24tooth)	745644 (24tooth)	745644 (24tooth)	745644 (24tooth)
118	Sprocket (Driver)	745639 (19tooth)	745637 (17tooth)	745641 (21tooth)	745636 (16tooth)	745639 (19tooth)
119	Sprocket (Double)	749552 (24tooth)	749552 (24tooth)	749552 (24tooth)	749552 (24tooth)	749552 (24tooth)
120	Hub (for PTO Sprocket)	230782& 7758291	230782& 7758291	230782& 7758291	230782& 7758291	230782& 7758291
121	Hub (for Driver Sprocket)	230953	2155220	230780	230752	230752
122	Hub (for Double Sprocket)	230793	230793	230793	230793	230793
123	Chain Tensioner	201121	201121	201121	201121	201121
124	SMC Pillow Block	400335	400335	400335	400335	400335

Dual Drive, 5 Horsepower

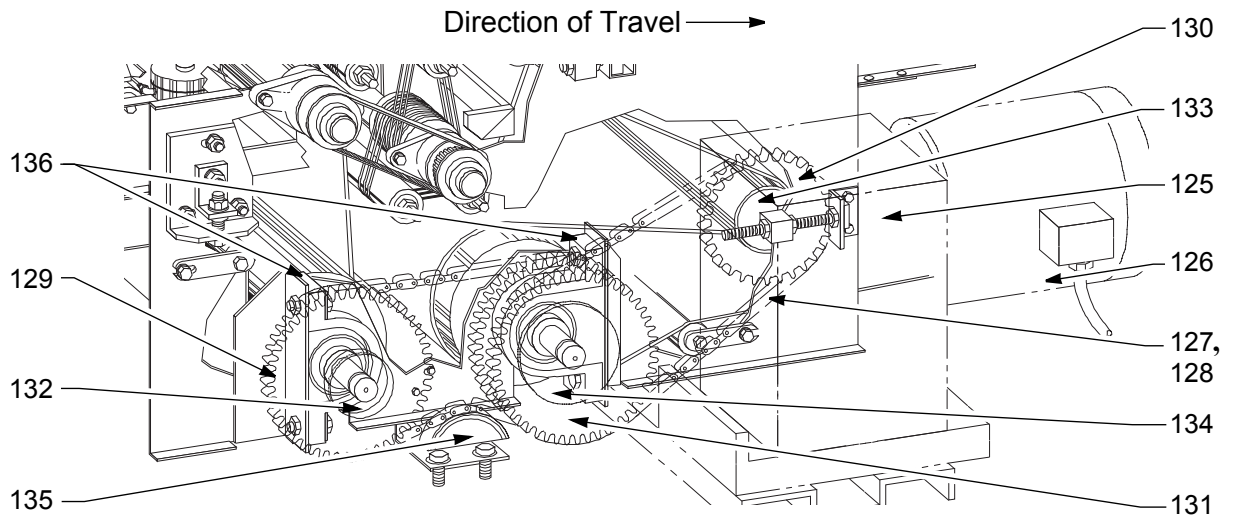

Figure I - 24 – Drive Assembly, Dual Drive Diverter

Table I - 25 – Dual Drive Diverter (RH & LH), 5 Horsepower

Key #	Part Description	Speed (FPM)				
		150	180	220	250	300
125	Gear Reducer (Right Hand)	811230	811228	811228	811224	811224
	Gear Reducer (Left Hand)	811229	811227	811227	811223	811223
126	Motor	330715	330715	330715	330715	330715
127	Chain	200987	200987	200987	200987	200987
128	Chain Coupler	7311060	7311060	7311060	7311060	7311060
129	Sprocket (PTO)	745644 (24tooth)	745644 (24tooth)	745644 (24tooth)	745644 (24tooth)	745644 (24tooth)
130	Sprocket (Driver)	745639 (19tooth)	745637 (17tooth)	745641 (21tooth)	745636 (16tooth)	745639 (19tooth)
131	Sprocket (Double)	749552 (24tooth)	749552 (24tooth)	749552 (24tooth)	749552 (24tooth)	749552 (24tooth)
132	Hub (for PTO Sprocket)	230782& 7758291	230782& 7758291	230782& 7758291	230782& 7758291	230782& 7758291
133	Hub (for Driver Sprocket)	230951	230951	230987	230953	230953
134	Hub (for Double Sprocket)	230793	230793	230793	230793	230793
135	Chain Tensioner	201121	201121	201121	201121	201121
136	SMC Pillow Block	400335	400335	400335	400335	400335

Dual Drive, 7.5 Horsepower

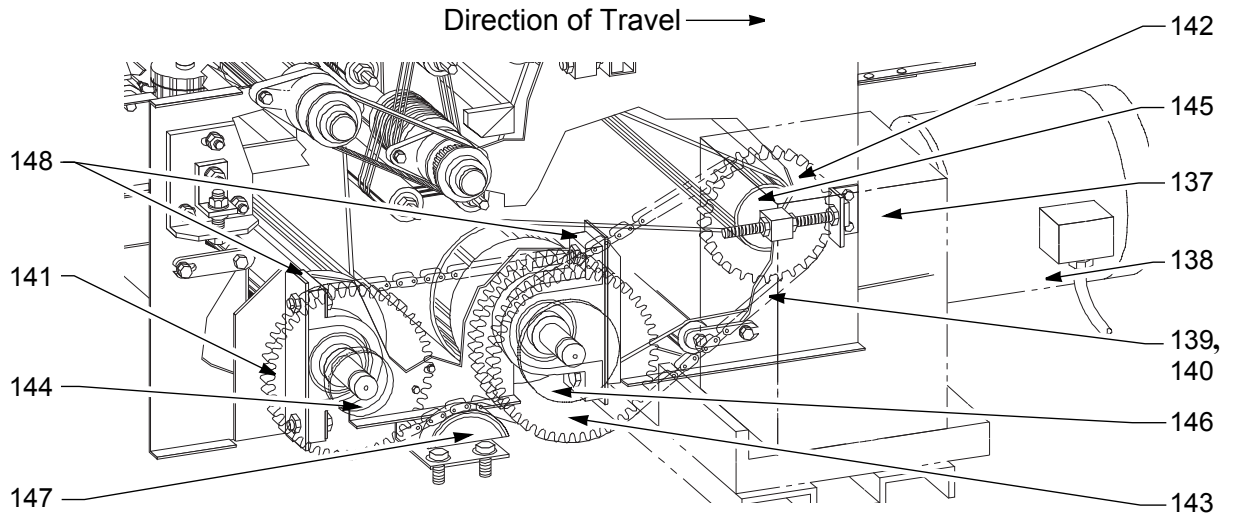

Figure I - 26 – Drive Assembly, Dual Drive Diverter

Table I - 27 – Dual Drive Diverter (RH & LH), 7.5 Horsepower

Key #	Part Description	Speed (FPM)				
		150	180	220	250	300
137	Gear Reducer (Right Hand)	811236	811234	811234	811232	811232
	Gear Reducer (Left Hand)	811235	811233	811233	811231	811231
138	Motor	330721	330721	330721	330721	330721
139	Chain	200989	200989	200989	200987	200987
140	Chain Coupler	200988	200988	200988	7311060	7311060
141	Sprocket (PTO)	745694 (23tooth)	745694 (23tooth)	745694 (23tooth)	745644 (24tooth)	745644 (24tooth)
142	Sprocket (Driver)	745689 (18tooth)	745687 (16tooth)	745691 (20tooth)	745636 (16tooth)	745639 (19tooth)
143	Sprocket (Double)	749553 (23tooth)	749553 (23tooth)	749553 (23tooth)	749552 (24tooth)	749552 (24tooth)
144	Hub (for PTO Sprocket)	230793	230793	230793	230782& 7758291	230782& 7758291
145	Hub (for Driver Sprocket)	230786	230786	230798	230951	230951
146	Hub (for Double Sprocket)	230806	230806	230806	230793	230793
147	Chain Tensioner	201122	201122	201122	201121	201121
148	SMC Pillow Block	400335	400335	400335	400335	400335

Dual Drive, 10 Horsepower

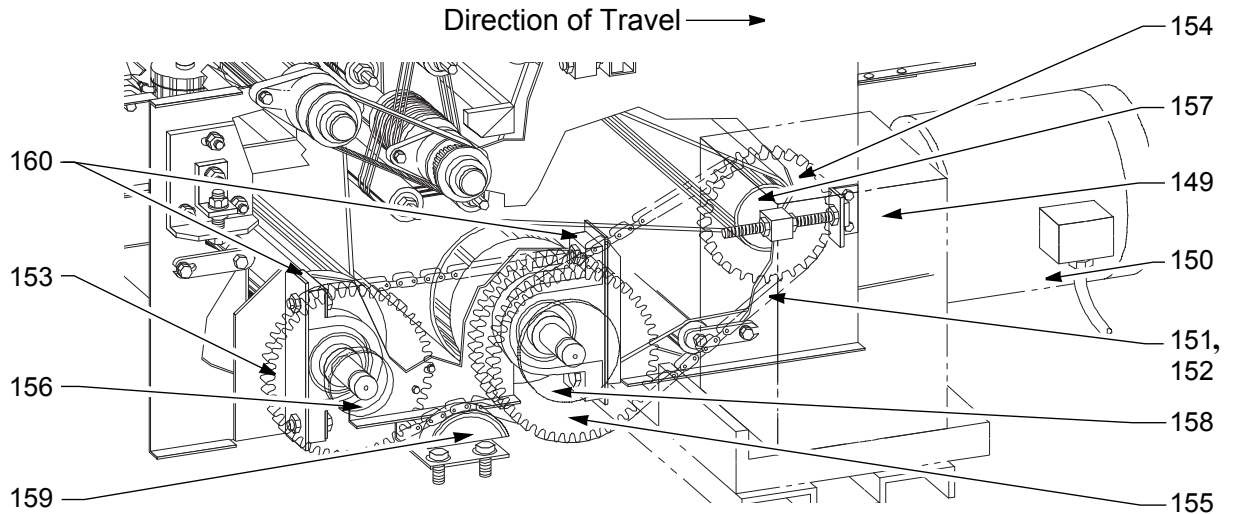

Figure I - 28 – Drive Assembly, Dual Drive Diverter

Table I - 29 – Dual Drive Diverter (RH & LH), 10 Horsepower

Key #	Part Description	Speed (FPM)				
		150	180	220	250	300
149	Gear Reducer (Right Hand)	–	811240	811240	811266	811266
	Gear Reducer (Left Hand)	–	811239	811239	811237	811237
150	Motor	–	330723	330723	330723	330723
151	Chain	–	200989	200989	200989	200989
152	Chain Coupler	–	200988	200988	200988	200988
153	Sprocket (PTO)	–	745694 (23tooth)	745694 (23tooth)	745694 (23tooth)	745694 (23tooth)
154	Sprocket (Driver)	–	745687 (16tooth)	745691 (20tooth)	745802 (15tooth)	745689 (18tooth)
155	Sprocket (Double)	–	749553 (23tooth)	749553 (23tooth)	749553 (23tooth)	749553 (23tooth)
156	Hub (for PTO Sprocket)	–	230793	230793	230793	230793
157	Hub (for Driver Sprocket)	–	230786	230798	230864	230786
158	Hub (for Double Sprocket)	–	230806	230806	230806	230806
159	Chain Tensioner	–	201122	201122	201122	201122
160	SMC Pillow Block	–	400335	400335	400335	400335

Dual Drive, 15 Horsepower

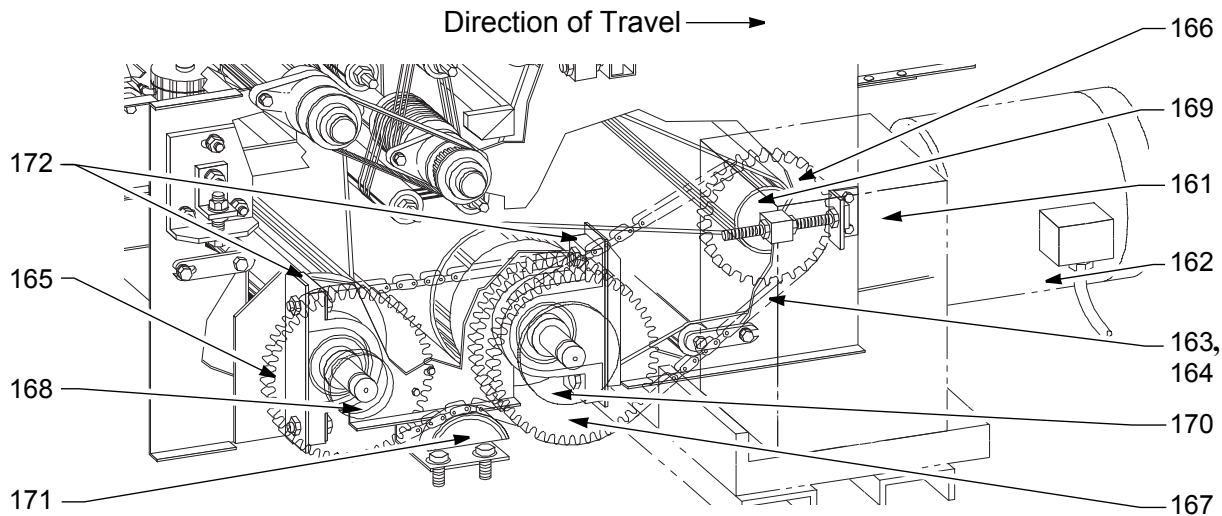
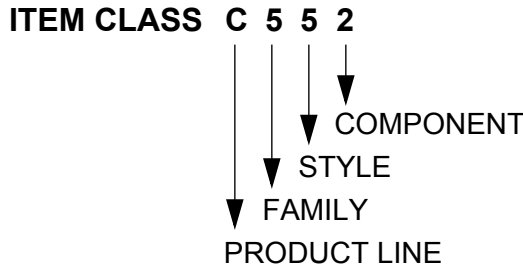

Figure I - 30 – Drive Assembly, Dual Drive Diverter

Table I - 31 – Dual Drive Diverter (RH & LH), 15 Horsepower

Key #	Part Description	Speed (FPM)				
		150	180	220	250	300
161	Gear Reducer (Right Hand)	–	–	811242	811244	811244
	Gear Reducer (Left Hand)	–	–	811241	811243	811243
162	Motor	–	–	330725	330725	330725
163	Chain	–	–	200989	200989	200989
164	Chain Coupler	–	–	200988	200988	200988
165	Sprocket (PTO)	–	–	745694 (23tooth)	745694 (23tooth)	745694 (23tooth)
166	Sprocket (Driver)	–	–	745691 (20tooth)	745802 (15tooth)	745803 (18tooth)
167	Sprocket (Double)	–	–	749553 (23tooth)	749553 (23tooth)	749553 (23tooth)
168	Hub (for PTO Sprocket)	–	–	230793	230793	230793
169	Hub (for Driver Sprocket)	–	–	230798	230866	230866
170	Hub (for Double Sprocket)	–	–	230806	230806	230806
171	Chain Tensioner	–	–	201122	201122	201122
172	SMC Pillow Block	–	–	400335	400335	400335

SECTION J: PRODUCT INDEX



UniSort IV Medium Speed

F1)

Description	Dwg No.	15" B/B	21" B/B	27" B/B	33" B/B
MSS RH Intermediate Diverter	17780	000951	000952	000953	000954
MSS LH Intermediate Diverter	17780	000956	000957	000958	000959
MSS RH End Diverter	17779	000961	000962	000963	000964
MSS LH End Diverter	17779	000966	000967	000968	000969
MSS RH Dual Snub Diverter	17778	000971	000972	000973	000974
MSS LH Dual Snub Diverter	17778	000976	000977	000978	000979
MSS RH TK/ID IF Diverter	17770	000981	000982	000983	000984
MSS LH TK/ID IF Diverter	17770	000986	000987	000988	000989

Note: Snub rollers G251GHS (1) for End Diverter and (2) for Dual Snub Diverter are in field kit. All diverters have mounting hardware in field kit.

F1) Required Option for Power Units

Description	Dwg No.	15" B/B	21" B/B	27" B/B	33" B/B
MSS RH Drive Diverter SM	18106	000911	000912	000913	000914
MSS LH Drive Diverter SM	18106	000915	000916	000917	000918
MSS RH Dual Drive Diverter SM	18092	000941	000942	000943	000944
MSS LH Dual Drive Diverter SM	18092	000945	000946	000947	000948

Nordic Soft Start Electrical Controls (NEMA 12)

Description	230V	Nordic PT#	460V	Nordic PT#
Soft Start 5 HP	304127	2534*01	304125	2534G01
Soft Start 10 HP	304129	2534K01	304126	2534I01
Soft Start 20 HP	304131	2534N01	304128	2534K01
Soft Start 40 HP	NA	NA	304130	254N01

The assemblies below have no options.

Description	Dwg No.	15" B/B	21" B/B	27" B/B	33" B/B
MSS GWJ RH 45 DEG	18107 and	426001	426003	426004	426005
MSS GWJ LH 45 DEG	18090	425002	426006	426007	426008
Fil/Reg/Gage 3/8" Arrow	NA	271738			
Air Pressure Switch	NA	302407			
MSS Return Roller Bracket Assy	15069	670453	670454	670455	670-456

- DIV = Diverter
- DR = Drive
- FPM = Feet Per Minute
- GWJ = Gravity Wheel Section
- HP = Horsepower
- HS = High Speed
- ID = Idler
- IF = Interface
- LH = Left Hand
- MSS = UniSort 4
- RH = Right Hand
- SM = Side Mounted
- TK = Take Up