

**Field Manual**  
**Powered Belt Conveyor**

Installation Procedures, Maintenance, and  
Parts Identification



To contact Intelligrated:  
For service: Customer Service and Support (CSS)  
Hotline 1-877-315-3400  
On the World Wide Web: [www.intelligrated.com](http://www.intelligrated.com)

By mail:

Intelligrated  
7901 Innovation Way  
Mason, OH 45040

(513) 701-7300

Read these documents thoroughly before attempting to perform maintenance or repairs to the applicable Intelligrated conveyor system components or devices. Exercise extreme caution when working around moving and rotating conveyor equipment. Wear the proper clothing and safety equipment. **DO NOT** attempt to perform any maintenance until the equipment is de-energized, locked out and tagged out in accordance with established company procedures.

The information presented in these documents are correct at the time of publication. Intelligrated has made every effort to ensure that the information presented is correct and free from error. However, some errors or misprints may occur. Please contact Intelligrated with any corrections.

This document is copyrighted © 2010 by Intelligrated, all rights reserved. No Part of this manual may be reproduced and/or distributed to parties other than the customer and the customer's employees for whom it was originally produced.

The following terms are trademarks™ of Intelligrated; Accuglide™, BOSS™ UniSort™, EZ-set™. The following terms are registered trademarks® of Intelligrated; Accuzone®, UniSort®, E-Z Set®. Intelligrated® is a registered trademark.

Direct questions and comments concerning the information contained in this manual to:

Documentation Department  
Intelligrated  
7901 Innovation Way  
Mason, OH 45040

Ph (513) 701-7300  
Fax (513)701-7349

[customerservice@intelligrated.com](mailto:customerservice@intelligrated.com)



# Package Conveyors



 <p><b>Do Not Climb, Sit, Stand, Walk, Ride, or Touch the Conveyor at Any Time</b></p>	 <p><b>Do Not Perform Maintenance on Conveyor Until Electrical, Air, Hydraulic and Gravity Energy Sources Have Been Locked Out or Blocked</b></p>	 <p><b>Operate Equipment Only With All Approved Covers and Guards in Place</b></p>
 <p><b>Do Not Load a Stopped Conveyor or Overload a Running Conveyor</b></p>	 <p><b>Ensure That All Personnel Are Clear of Equipment Before Starting</b></p>	 <p><b>Allow Only Authorized Personnel To Operate or Maintain Material Handling Equipment</b></p>
 <p><b>Do Not Modify or Misuse Conveyor Controls</b></p>	 <p><b>Keep Clothing, BodyParts, and Hair Away from Conveyors</b></p>	 <p><b>Remove Trash, Paperwork, and Other Debris Only When Power is Locked Out and Tagged Out</b></p>
 <p><b>Ensure That ALL Controls and Pull Cords are Visible and Accessible</b></p>	 <p><b>Know the Location and Function of All Stop and Start Controls</b></p>	 <p><b>Report All Unsafe Conditions Jams should be cleared ONLY BY Authorized, Trained, Personnel</b></p>

POST IN PROMINENT AREA



---

## Field Manual Issue and Revision Date(s)

1st Issue	April 2001
Previous Revision	December 2006
Current Revision	September 2007

## Field Manual Revision Summary

<b>Revision Date</b>	<b>Manual Section(s)</b>	<b>Revision Summary</b>
December 2006	Section I	Update Carrier Roller Part Numbers
September 2007	All	Footer Correction - Issue Date



---

**Section G Installation Procedures**

Accepting Shipment	G - 1
Shortages or Errors	G - 1
Lost or Damaged Shipment	G - 1
Claims and Returns	G - 1
Codes and Standards	G - 1
Warning Signs	G - 2
Safety Precautions	G - 2
Parts Replacement	G - 2
Factory Assistance	G - 2
Pre-Installation Set-up	G - 2
Style Identification	G - 3
Assembling the Bed Section	G - 7
Power Unit Assembly	G - 10
Lubricant	G - 10
Reducer Plugs/Fittings	G - 10
Sprocket Alignment	G - 10
Set Screw Tightening Procedure (Type B Sprockets)	G - 10
Installing the Upper Bend Unit	G - 11
Installing the Power Feeder and/or Jackknife Unit	G - 12
Connector Channel Assemblies	G - 13
Installing the Belt	G - 14
Cutting the Belt Ends	G - 15
Splicing the Belt	G - 15
Replacing the Belt(s)	G - 16
Installing Electrical Wiring	G - 17
Pre-Start-Up Preparation	G - 17
Pre-Operation Check List	G - 17
Belt Tracking	G - 18
Principles of Belt Tracking	G - 18
Belt Tracking Instructions	G - 18
Examples of Belt Tracking	G - 18
Belt Tracking Check List	G - 22
Adjusting Belt Tension	G - 23
Adjusting Snub Rollers	G - 24

---

**Section H Maintenance**

General	H - 1
Maintenance Safety	H - 1
New Installations	H - 1
Maintenance Logs	H - 1
Initial Start-up and Run-in Period	H - 1
Chain and Sprockets	H - 1
Power Unit Reducer	H - 2
Scheduled Inspections and Maintenance	H - 2
Daily Inspections	H - 3
Weekly Inspections	H - 3
Belting	H - 3
Belt Lacing	H - 3
Carrier and Belt Return Rollers	H - 3
General Structure and Operation	H - 3
Power Unit Reducer	H - 3
Safety Guards and Devices	H - 3
Electrical Devices	H - 3
Monthly Maintenance	H - 4
External Bearings	H - 4
Internal Bearings	H - 4
Power Unit Motor	H - 4
Power Unit Motor/Brake	H - 4
Power Unit Reducer	H - 4
Power Unit Sprockets	H - 4
Power Unit Chains	H - 4
Power Unit Timing Belts	H - 5
Drive Sprockets	H - 5
Drive Pulley and Lagging	H - 5
Supports and Hangers	H - 6
Semi-Annual Maintenance	H - 6
Power Unit Motor	H - 6
Power Unit Reducer	H - 6
External Pulley Bearings	H - 6
Internal Bearings	H - 6
Replacing the Belt(s)	H - 7
Troubleshooting	H - 7



---

**Section I Spare Parts**

General Information	-----	- 1
Intermediate Sections	-----	- 1
Roller Bed	-----	- 1
Slider Bed	-----	- 1
Box Bed	-----	- 1
End Drives	-----	- 2
Series 400 with Take-Up	-----	- 2
Series 600 and 800 with Take-Up	-----	- 2
End Idlers	-----	- 3
Series 400, 600, and 800	-----	- 3
Knife Edge Assembly	-----	- 3
Intermediate Drives	-----	- 4
SA2000 - Intermediate Section	-----	- 4
SA2001 - Intermediate Section - Low Profile	-----	- 5
Auxiliary Take-Up Sections	-----	- 6
Manual (3.5" Pulleys)	-----	- 6
Manual (6" Pulleys)	-----	- 6
Automatic (Air) (6" Pulleys)	-----	- 6
Spring Take-Up	-----	- 7
Upper Bend Sections	-----	- 7
1.9" Rollers	-----	- 7
2.5" Rollers	-----	- 7
Power Units	-----	- 8
Under-hung Mount	-----	- 8
Side-Mounted	-----	- 8
Driven Jackknife	-----	- 9
Non-Driven Jackknife	-----	- 9
Power Feeders	-----	- 10
Incline	-----	- 10
Decline	-----	- 10
Reversible	-----	- 11
Non-Width Related Parts	-----	- 12
Width Related Parts	-----	- 28
Lubricants and Paints	-----	- 32



---

## **SECTION G:INSTALLATION PROCEDURES**

### **Accepting Shipment**

Immediately upon delivery, check that all equipment received agrees with the bill of lading or carrier's freight bill. Any shipping discrepancy or equipment damage should be clearly noted on the freight bill before signing.

### **Shortages or Errors**

Report any shortages or errors to the Manufacturer's Customer Service in writing within ten days after receipt of shipment.

### **Lost or Damaged Shipment**

Report lost shipments to the Manufacturer's Shipping Department.

If shipping damage is evident upon receipt of the conveyor equipment, note the extent of the damage on the freight bill and immediately contact the transportation carrier to request an inspection. Do not destroy the equipment crating and packing materials until the carrier's agent has examined them. Unless otherwise agreed by the manufacturer, the Purchaser (User) shall be responsible for filing claims with the transportation carrier. A copy of the inspection report along with a copy of the freight bill should be sent to the Manufacturer's traffic department.

### **Claims and Returns**

All equipment furnished in accordance with the Manufacturer's Agreement is not returnable for any reason except where authorized in writing by the Manufacturer. Notification of return must be made to the Manufacturer's Customer Service Department, and if approved, a "Return Authorization Tag" will be sent to the Purchaser (Users). The return tag sealed in the "Return Authorization Envelope" should be securely affixed to the exterior surface on any side of the shipping carton (not top or bottom), or affixed to any smooth flat surface on the equipment, if not boxed.

Send authorized return shipment(s) transportation charges prepaid to the address indicated on the Return Authorization Tag. If initial shipment is refused, the Purchaser (User) shall be liable for all freight charges, extra cost of handling, and other incidental expenses.

### **Codes and Standards**

The conveyor equipment is designed and manufactured to comply with the American National Standard Institute's "Safety Standards for Conveyors and Related Equipment" (ANSI B20.1) and with the National Electrical Code (ANSI/NFPA70).

The Purchaser/Operator shall be familiar with, and responsible for, compliance with all codes and regulations having jurisdiction regarding the installation, use, and maintenance of this equipment. Appropriate lockout/tagout policy and procedures shall comply with the minimum safety requirements outlined in the American National Standard Institute's current publication (ANSI Z244.1).

---

## Warning Signs

Warning signs and labels posted on or near the conveyor equipment shall not be removed, painted over, or altered at any time. All safety devices, warning lights, and alarms associated with the conveyor system should be regularly tested for proper operation and serviced as needed. If the original safety item(s) become defective or damaged, refer to the conveyor parts list(s) of bill(s)-of-materials for replacement part numbers.

## Safety Precautions

- DO turn off conveyor power source(s) and affix appropriate lockout/tagout device(s) to operating controls before servicing the equipment. ONLY trained and qualified personnel who are aware of the safety hazards should perform equipment adjustments or required maintenance while the conveyor is in operation.
- DO observe all warning signs, lights, and alarms associated with the conveyor operation and maintenance, and be alert at all times to automatic operation(s) of adjacent equipment.
- DO use extreme caution near moving conveyor parts to avoid the hazard of hands, hair, and clothing being caught.
- DO NOT sit on, stand on, walk, ride, or cross (over or under) the conveyor at any time except where suitable catwalks, gates, or bridges are provided for personnel travel.
- DO NOT attempt to repair any equipment while the conveyor is running, replace any conveyor component without appropriate replacement parts, or modify the conveyor system without prior approval by the manufacturer.
- DO NOT operate the conveyor until all safety guards are securely in place, all tools and non-product materials are removed from or near the conveying surfaces, and all personnel are in safe positions.
- DO NOT remove or modify any safety devices provided on or with the conveyor.
- DO NOT clear jams or reach into any unit before first turning off the equipment power source(s) and affixing appropriate lockout/tagout device(s).

## Parts Replacement

To minimize production downtime, selected conveyor spare parts should be stocked for replacement of defective components when required. Refer to the equipment bill(s)-of-materials where quantity requirements or code numbers are not indicated on the conveyor parts list. For added convenience, a list of selected spare parts for standard products is included in this manual (see Section I).

## Factory Assistance

Contact Field Service for installation, operation, or maintenance assistance, or Customer One Protection (COP) for replacement parts.

## Pre-Installation Set-up

Prior to installation, review the layout drawings to determine the proper location, orientation, and elevation of the conveyor sections. Read all instructions provided in this manual.

Review the plan drawings to identify the individual components that make up the conveyor unit and note the orientation, right-hand or left-hand, of the appropriate components and drives. Motor driven components (see Figures G - 1 through G - 4) have their orientation

shown on the plan of the conveyor by a box depicting a chain guard on one side of the conveyor.

Snap a chalk line on the floor or other support base to establish the centerline of the conveyor. Arrange the conveyor items and mounting supports along this base line according to the layout drawing to ensure that all components are present and are compatible for proper assembly. Leave field-installed rollers, photoelectric controls, and other accessory items in the shipping containers until all conveyor items are completely assembled, mounted on supports, and adjusted for proper elevation.

End drives are for one-way travel and must be assembled at the discharge end of the conveyor. One-way Intermediate Drives should be assembled as close as possible to the discharge end of the conveyor. Intermediate Drives for reversing operation should be located near the middle of the conveyor.

## **Style Identification**

Combinations of the equipment elements are varied. Figures G - 1 through G - 4 illustrate the conveyor styles that are available.

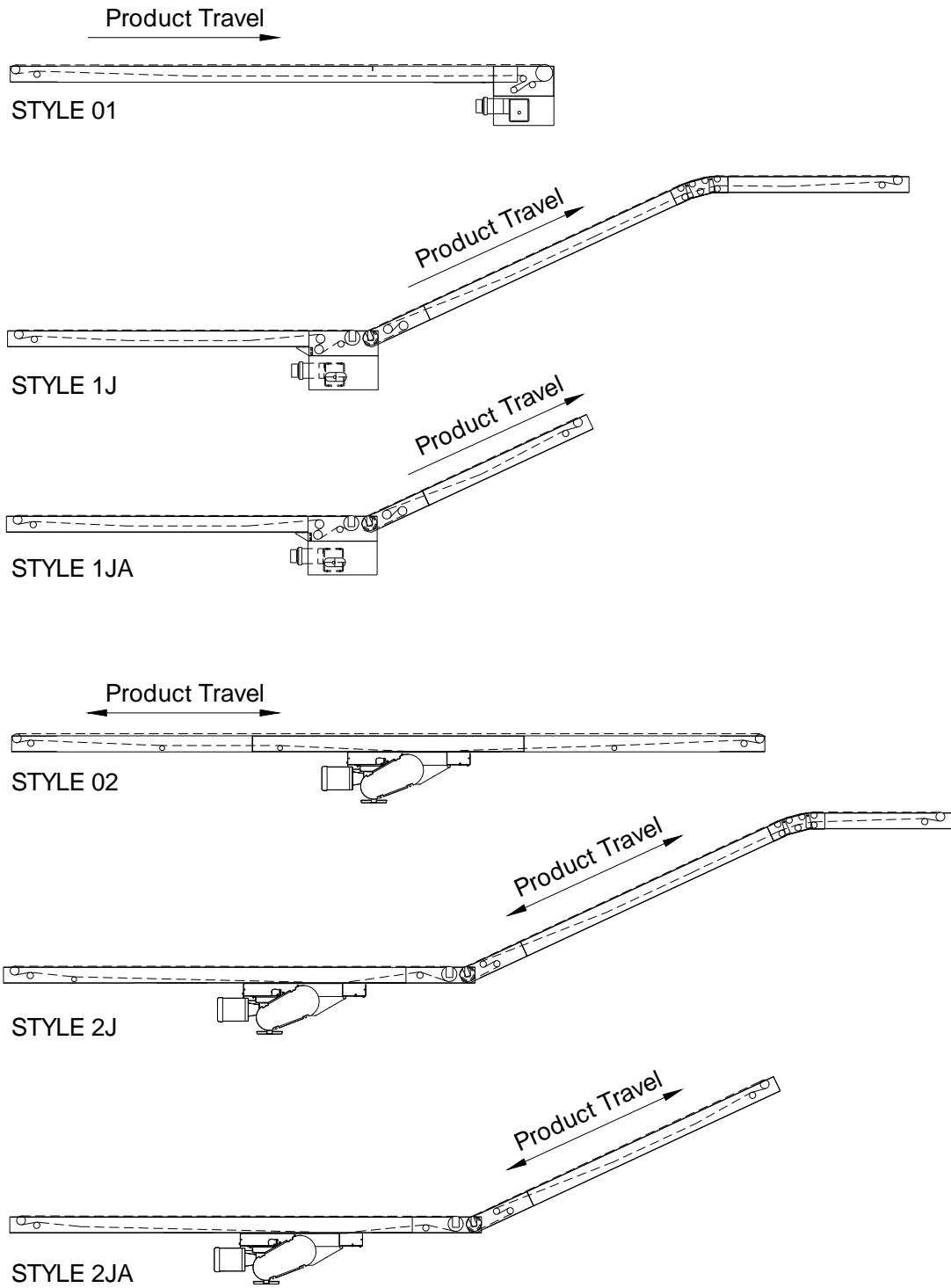

BUSFKI015A

Figure G - 1 Powered Belt Conveyor Style Identification - Sheet 1 of 4

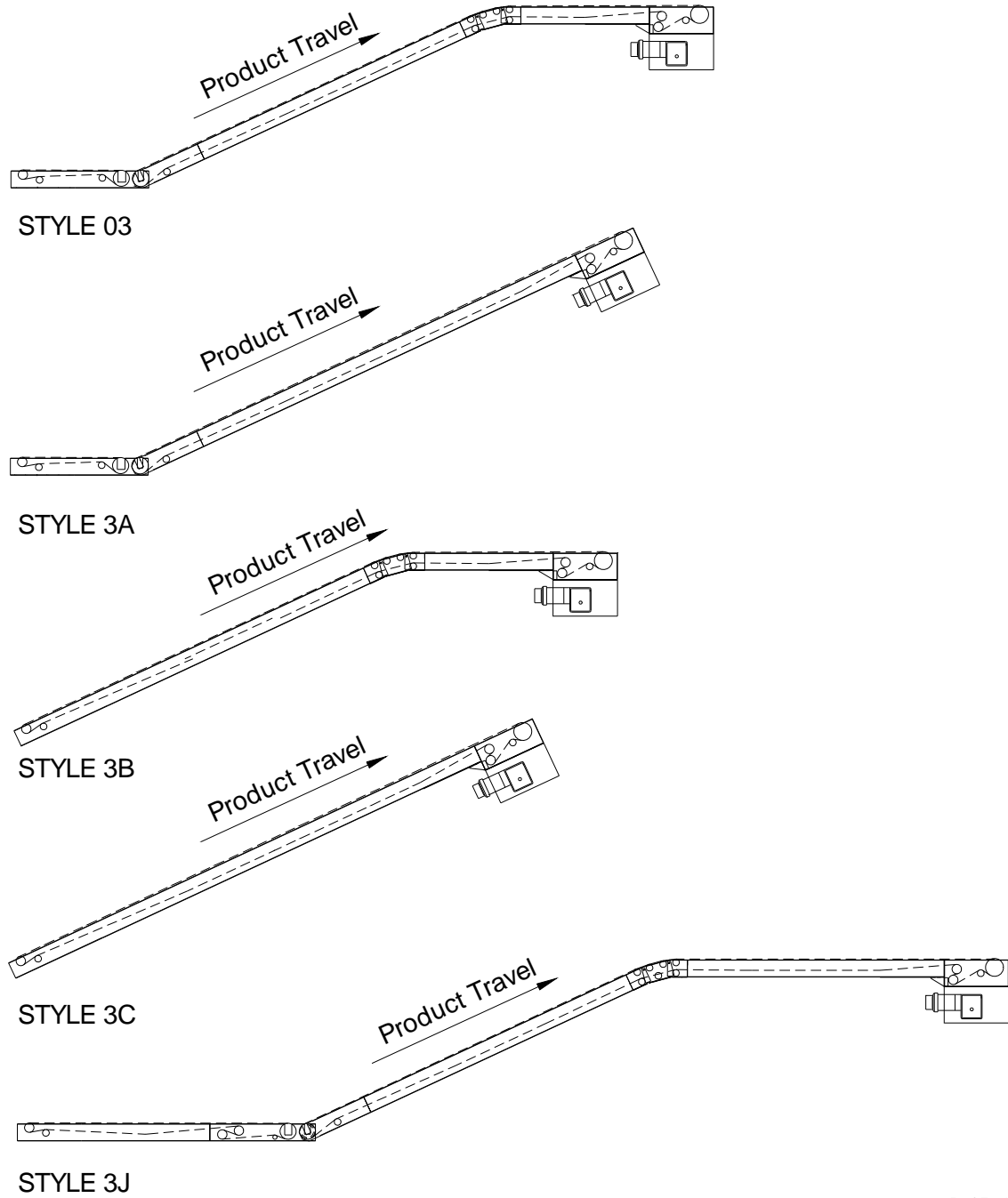

BUSFKI016A

Figure G - 2 Powered Belt Conveyor Style Identification - Sheet 2 of 4

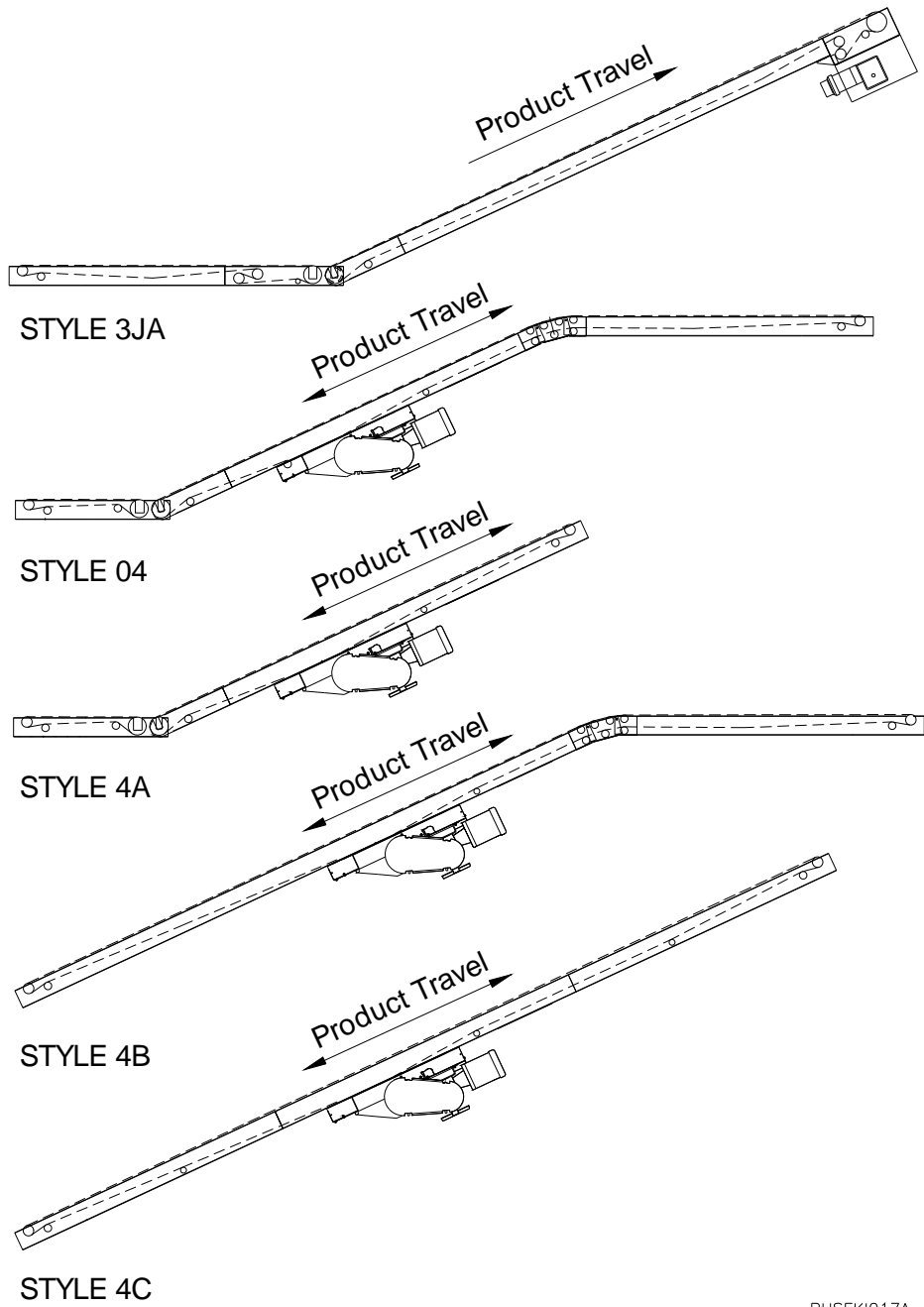

BUSFKI017A

Figure G - 3 Powered Belt Conveyor Style Identification - Sheet 3 of 4



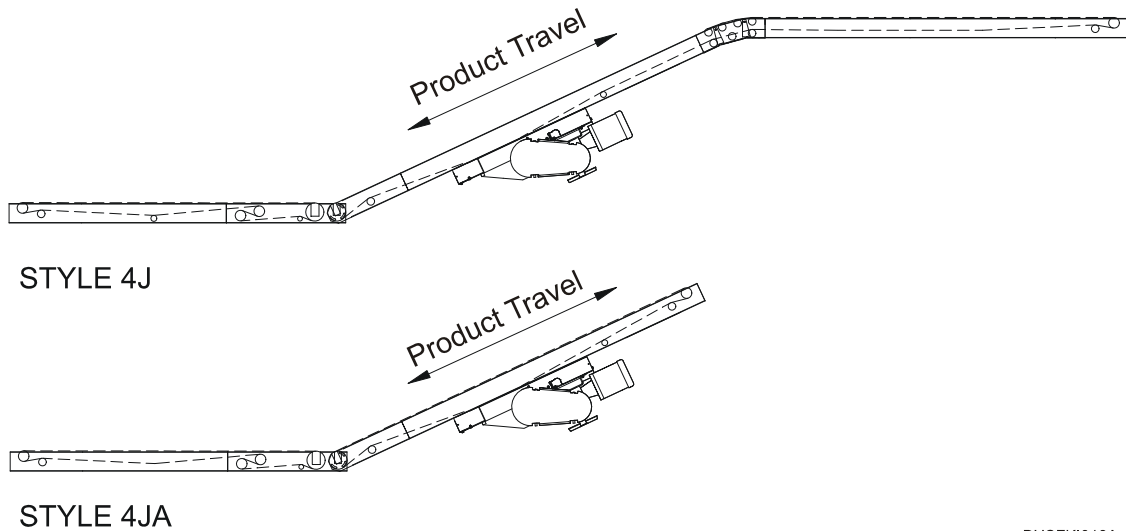

BUSFKI018A

Figure G - 4 Powered Belt Conveyor Style Identification - Sheet 4 of 4

## Assembling the Bed Section

Use the following steps to assemble the conveyor:

1. Remove any shipping braces and filler blocks and check the alignment of frames, pulleys, and rollers of each section before proceeding. Corner-to-corner diagonal frame measurements of each conveyor section should be equal within 1/16". Also, check that all idler rollers and pulleys rotate freely.
2. Starting at one end of the conveyor, attach two supports to the first section. Fasten it in place. See Figure G - 5 and Figure G - 6.

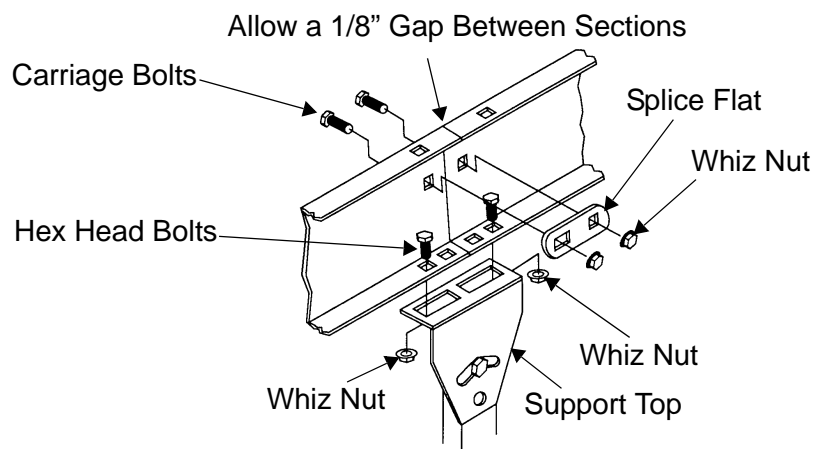

Figure G - 5 Standard Floor Support Assembly

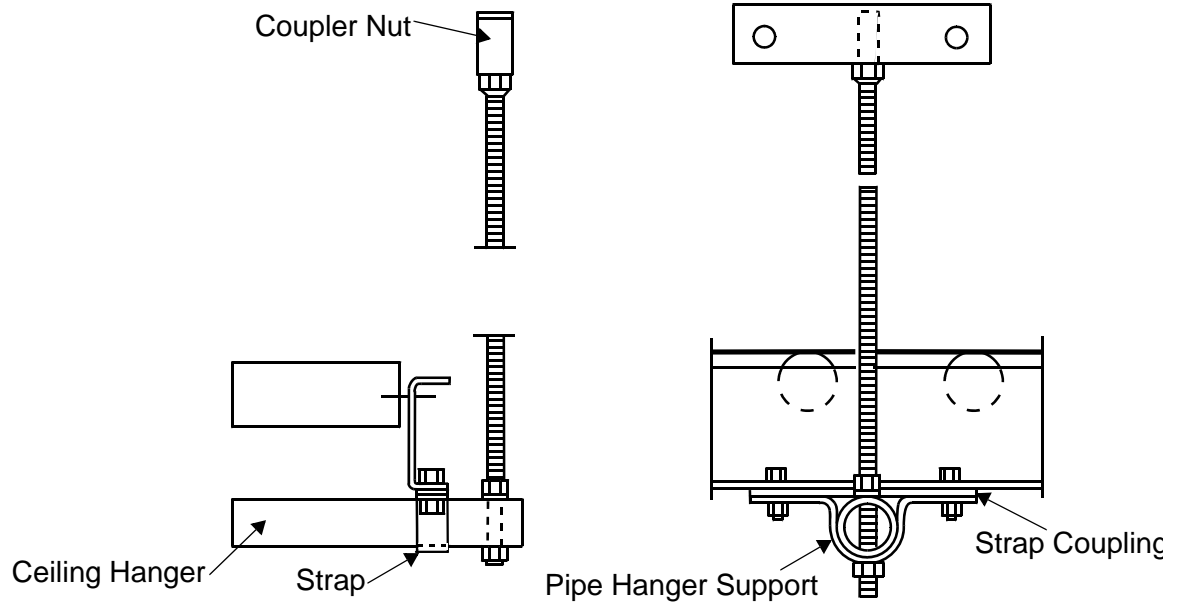

Figure G - 6 Ceiling Hanger Installation

3. Adjust the supports to the required height and level the conveyor section using a spirit level. Check the alignment of the frame, pulleys, and rollers.

**Note:** Frames, pulleys, and rollers **MUST** be square to properly track the belt. When the corner-to-corner squaring method is impractical, as with long narrow sections, use a steel square to check (and realign if necessary) pulleys, rollers, and bolted cross members to ensure they are mounted perpendicular to the conveyor side frames.

4. If not otherwise noted, return rollers should be mounted according to the following:
  - each 3'-0" and each 6'-0" long section has one return roller.
  - each 9'-0" and each 12'-0" long section has two return rollers, with the maximum distance between adjacent rollers not to exceed 6'-0".
5. Repeat steps 1 through 3 for the remainder of the conveyor sections. Position, align, level, square, and couple each conveyor section before moving to the next section.

If a splice is located directly over a support, the support and coupling strap securely couple the two sections together. If the splice is located somewhere other than over a support, a splice plate must be used. See Figure G - 7.

The maximum allowable center-to-center distance between supports is 12'-0".

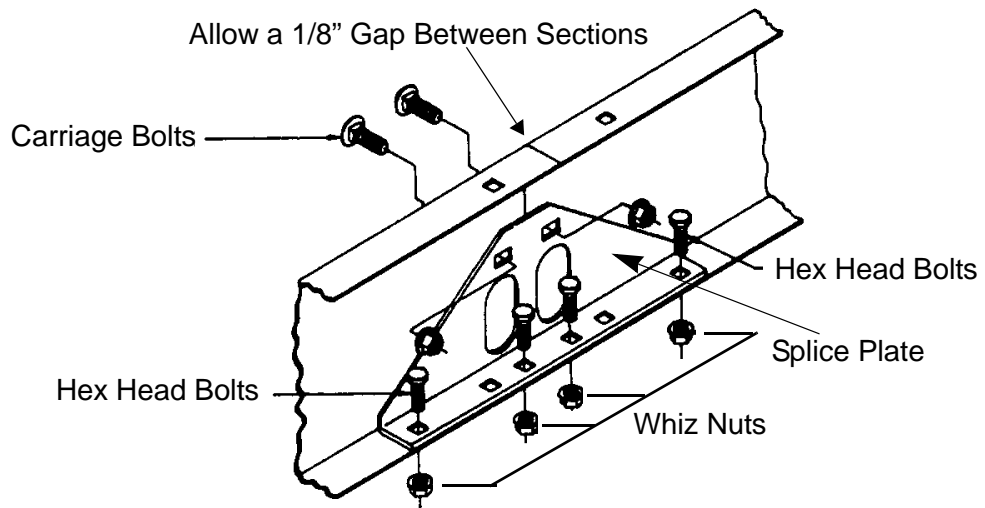

Figure G - 7 Splice Plate Assembly

## Power Unit Assembly

The Power Unit is shipped from the factory fully assembled to the drive section. When installing, check the following before starting.

### Lubricant

Check that the reducer lubricant is up to the “Oil Level Plug.” Before adding any lubricant, refer to the manufacturer’s tags attached to the reducer.

### Reducer Plugs/Fittings

Check that the oil level and drain plugs are properly installed and sufficiently tightened.

### Sprocket Alignment

**CAUTION:** Before working on a Power Unit or PTO unit, make certain the conveyor’s power disconnect is locked in the open position and tagged to prevent accidental or unexpected application of power.

Check alignment of chain and timing belt sprockets. See Figure G - 8.

Shafts (pulley and reducer) must be parallel.

For timing belt sprockets, misalignment should not exceed 1/4° (1/16” per foot of center distance).

See “Pre-Start-Up Preparation”, on page G - 17, for additional information.

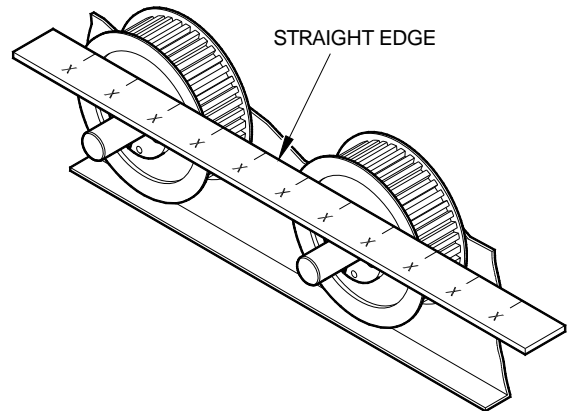

Figure G - 8 Checking Sprocket Alignment

8140TBC020a

### Set Screw Tightening Procedure (Type B Sprockets)

Check that set screws are tight. See Figure G - 9.

Use the following steps to tighten the set screws:

1. “Snug-up” both set screws.
2. Tighten (in sequence) “A” 25%, “B” 50%, “A” 75%, “B” 100%, and finally “A” 100% of recommended torque rating. See Table G 1 for recommended torque ratings.

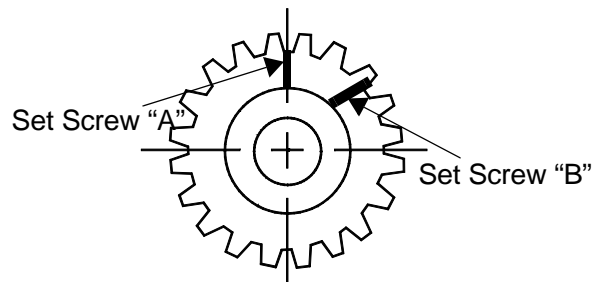

Figure G - 9 Type B Sprocket/Hub

Table G 1: Recommended Set Screw Torque

1/4”-20	5/16”-18	3/8”-16
70 inch-lbs.	130 inch-lbs.	230 inch-lbs.

## Installing the Upper Bend Unit

Upper Bend Units are shipped from the factory fully assembled at a pre-set angle of 30° (15° at each pivot point). The Upper Bend Unit is attached to a terminal end (End Drive or End Idler unit), or shipped separately to be attached on location to the Intermediate Sections when the conveyor has a horizontal run-out.

If the conveyor's angle of incline is other than 30°, it is recommended that the unit be reset to the required angle before the conveyor is installed. Use the following steps when resetting the unit's angle of incline:

1. Remove four Hex Head bolts (1/4" x 1/2") from the upper bend assembly. See Figure G - 9.
2. Loosen two 3/8" Hex Head bolts in each plate connection and swing each section to a setting that is 1/2 of the required angle.
3. Insert the 1/4" bolts into the appropriate hole (inset) in each of the four connections.
4. Retighten all bolts.

**Note:** The above instructions are provided for incline settings in 5° increments. If other than a 5° increment is required, use the following:

1. Follow steps 1 and 2 (above).
2. Retighten the 3/8" bolts.
3. Use a hole in the outer plate as a pilot and drill a new 1/4" diameter clearance hole in each plate connection.
4. Insert the 1/4" bolts into the new holes.
5. Retighten all bolts.

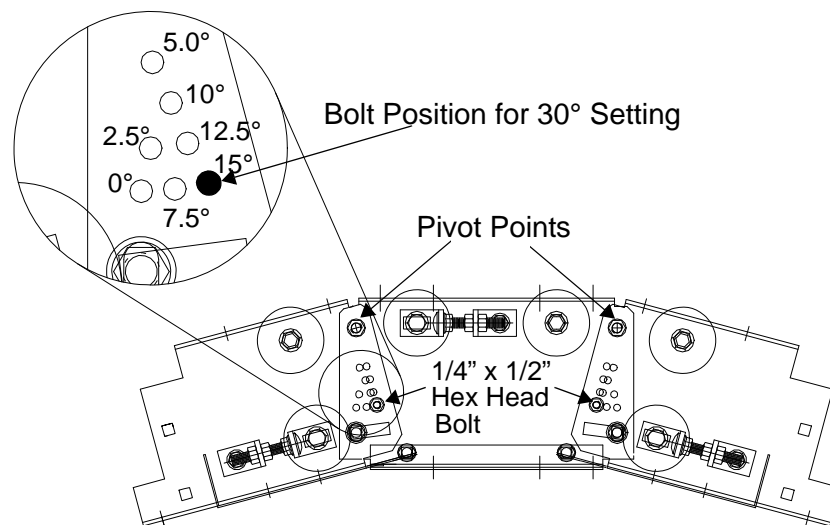

Figure G - 9 Upper Bend Unit

## Installing the Power Feeder and/or Jackknife Unit

Power Feeder Units are shipped from the factory fully assembled and ready to be attached to the intermediate bed section of the main inclined conveyor in the same manner as adjoining two Intermediate Sections. Mounting materials are shipped in hardware cartons. See Figure G - 5, Figure G - 10, Figure G - 11, and Figure G - 12.

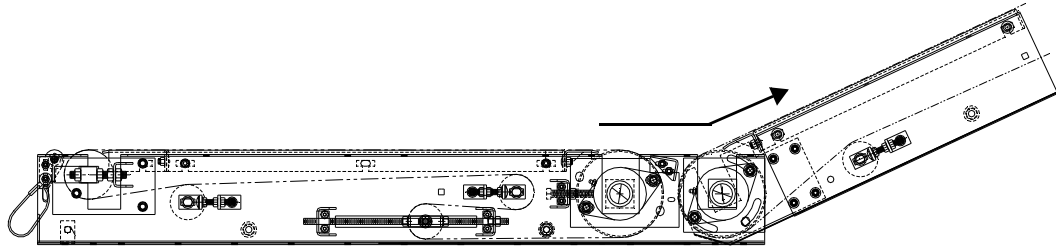

Figure G - 10 Power Feeder for Incline Conveyor

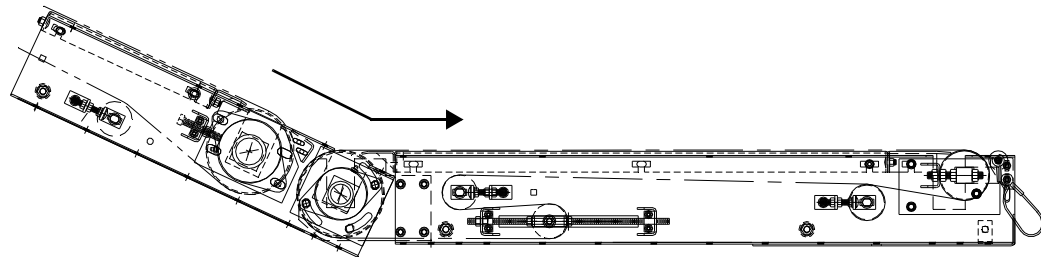

Figure G - 11 Power Feeder for Decline Conveyor

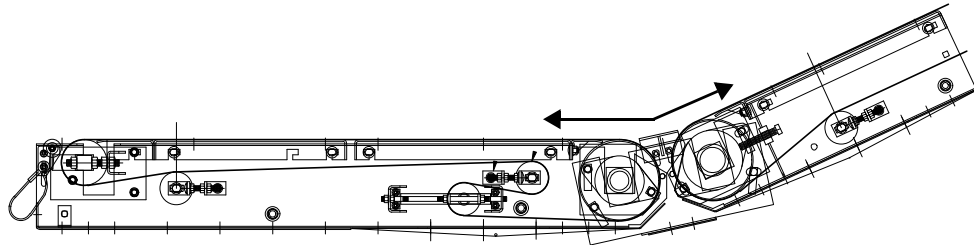

Figure G - 12 Power Feeder for Reversible Conveyor

## Connector Channel Assemblies

The adjoining terminal ends of two separate conveyors can be supported by a single floor support or ceiling hanger if the system is furnished with Connector Channel assemblies. See Figure G - 13. These assemblies consist of Connector Channels and Fill Flats that compensate for the difference in heights of various terminal ends. See Figure G - 14.

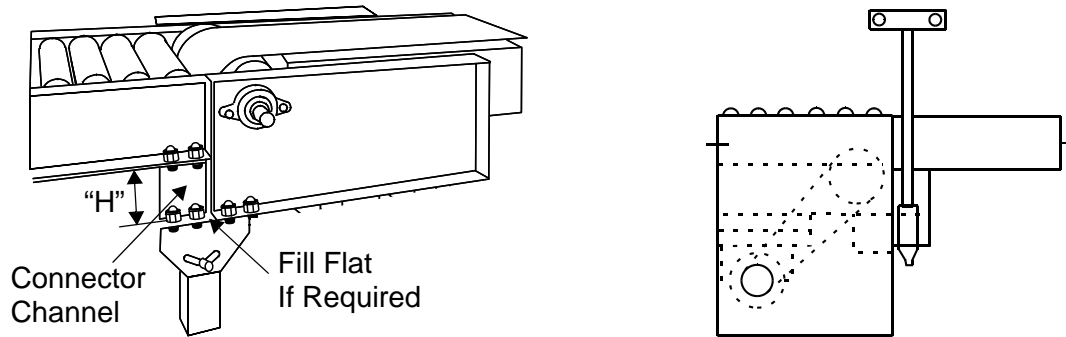

Figure G - 13 Connector Channel

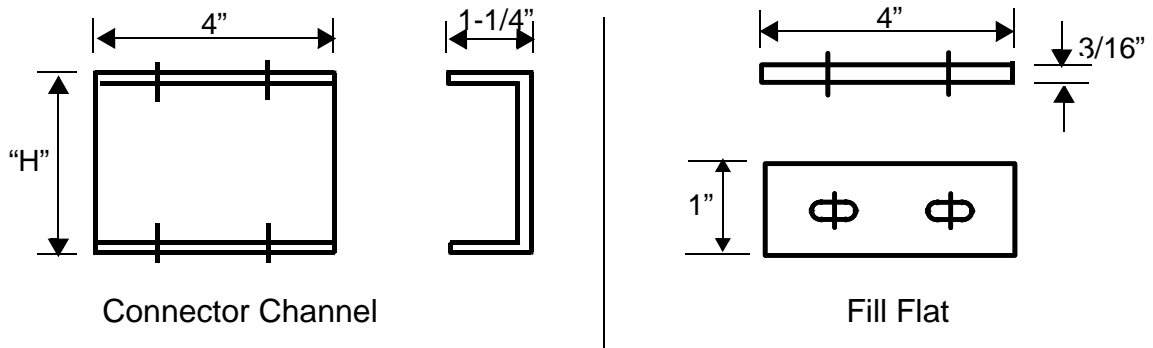

Figure G - 14 Connector Channel and Fill Flat Details

For example, when connecting a belt conveyor to a live roller or accumulator conveyor, the adjustable fill flats are inserted between the support top and the end plates of the roller type conveyor to keep the elevations of the belt and carrier rollers the same.

**Note:** These flats are not needed when connecting to another belt conveyor and may be discarded in such cases.

Each Connector Channel assembly includes:

- Connector channels with proper required dimensions
- Two adjustable fill flats
- Four 3/8" x 1" bolts with nuts, washers, etc.

**Note:** These parts are shipped in hardware cartons.

## Installing the Belt

Use the following steps to install the belt.

1. Before starting belt installation, make certain that:
  - all frame sections are level, properly aligned, and securely anchored,
  - all pulley and roller shafts are perpendicular to the conveyor frame,
  - all idler pulleys and rollers rotate freely,
  - no dips or humps exist along the conveyor bed surface, and
  - all sections are level.
2. Adjust all take-ups to their minimum take-up position.
3. Measure the required belt length.

For a short conveyor, thread a tape or rope through the conveyor following the path the belt will take and measure. Cut the belt to this length.

For longer units, the length of the conveyor can be doubled and 4'-0" added. This gives the approximate belt length required and cut to the approximate belt length.

4. Orient the belt properly on the unit.

For minimum friction (less belt drag), particularly on slider bed units, the brushed, non-glossy side of the belt must be face-down on the top side of the conveyor.

5. Thread the belt through the conveyor. Thread the belt through the bottom of the conveyor first. Position the belt near one end of the conveyor such that the brushed side of the belt is up and the first pulley to be encountered by the belt is the drive pulley. Large rolls of belting should be mounted on a shaft for ease of unrolling.

An alternative is to unroll the belt and lay it on the floor in large loops, taking care to avoid kinking the belt. The belt may then be pulled from the pile in the same manner it is pulled from a coil. Attach a suitable pulling clamp and cable to the lead end of the belt. See Figure G - 15. The clamp should distribute the pull evenly across the width of the belt. Then, with the assistance of a puller on the cable or rope, the lead end of the belt can be guided through the final path, around drive and take-up pulleys, over return rollers, around end pulleys, and finally, up to the top of the conveyor where it can be joined with the other end.

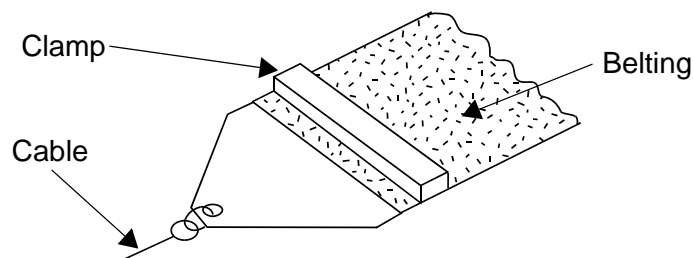

Figure G - 15 Belt Pulling Device



## Cutting the Belt Ends

Use the following steps to cut the belt ends:

1. Pull the belt ends together and secure them to the bed with appropriate clamps. See Figure G - 16. If excess belt remains, overlap the belt ends and pull the belt until the belt sag between the return rollers is about 1" (with conveyor take-up at minimum take-up position); then mark the cut line with chalk or pencil.

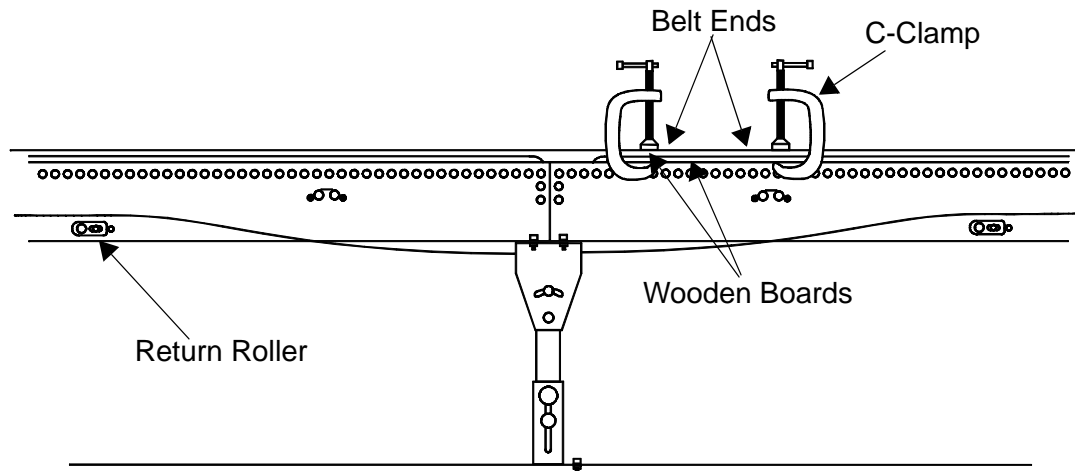

Figure G - 16 Clamping Belt Ends

2. Belt ends must be cut precisely square to ensure proper belt tracking and even distribution of the tension load through the belt splice.
  - Using chalk or pencil, mark the center of the belt at a number of points about 1 ft. apart in the vicinity of the planned cut.
  - Using a straightedge, mark the centerline of the belt by passing the line through as many center marks as possible.
  - Using a steel square, mark the cut line perpendicular to the drawn centerline.
  - Carefully cut the belt with a sharp knife or belt cutting tool.
3. Recommended: Corners on squared cut ends of the belt should be chamfered by cutting off a triangle measuring 1/2" (along the belt width) by 1-1/2" (measured along the belt length).
4. Recommended: Rough tops, ribs, chevrons, etc. should be skived back about 1" from the belt ends before lacing.

**Note:** Skiving is assumed by belting and lacing manufacturers when sizing belt fasteners for these types of belts.

## Splicing the Belt

Splice the belt with the supplied lacing. Follow the lacing manufacturer's instructions.

## Replacing the Belt(s)

When replacing the belt(s), it may be beneficial in certain applications to splice the belt on a bias to reduce noise. When the belt is spliced on a bias, Intelligrated engineering requires the angle of the splice to be less than 7 degrees. Use the table below as a guide for common belt widths and dimensions. Each end of the belt must be cut at the exact same angle to ensure proper belt tracking. Be sure to take the offset measurement before trimming 1/4" from the corners, so as not to exceed the maximum bias angle.

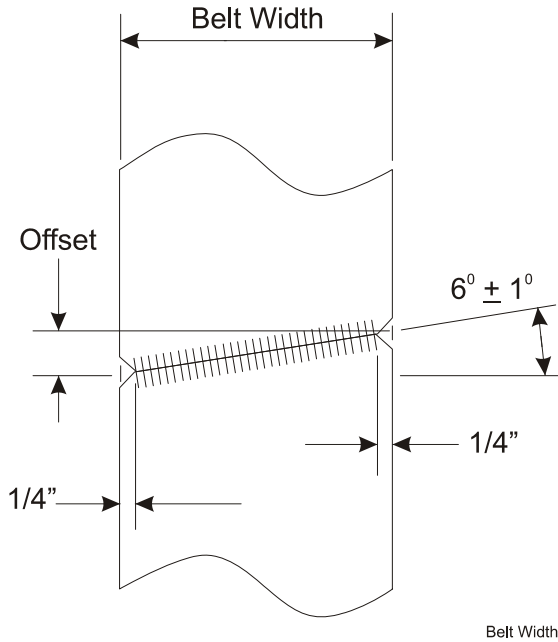

Common Belt Widths	Offset Dimension for 6 Degree Bias
12"	1-1/4"
18"	1-7/8"
24"	2-1/2"
30"	3-1/8"
36"	3-13/16"

---

## Installing Electrical Wiring

Electrical wiring must be installed by a competent licensed electrician. The licensed electrician must be familiar with the operation and adjustment requirements of the conveyor so that the conduit and apparatus do not interfere with required access.

A lockable disconnect switch, rated to the service, must be mounted near and wired to each drive motor. All power to be connected to the motor must be routed through the disconnect switch. This will permit local physical lockout of the motor by persons making repairs or adjustments to the drive.

After completion of the wiring, the electrician should “bump” each drive motor, and if necessary, modify the connections to achieve proper rotation for the required direction of belt travel.

## Pre-Start-Up Preparation

---

---

**CAUTION:** To prevent accidental start-up, make certain electrical power to the Power Unit is turned off and locked out.

---

---

## Pre-Operation Check List

The following describes the check list prior to equipment start-up:

1. Check conveyor elevation and adjust supports as needed.
2. Check conveyor alignment (lengthwise and width wise) with a spirit level. Adjust supports or add shims as needed and securely tighten all mounting bolts.
3. Check that all pulleys and rollers are mounted perpendicular (90°) to the direction of belt travel.
4. Check belt sag and adjust take-up pulley as needed. Do not over tension the belt.
5. Check driver/driven sprocket alignment with a straightedge. Securely tighten all sprocket fasteners.
6. Check drive chain tension and adjust as needed. Securely tighten all mounting bolts.
7. Check motor wiring connections.
8. Check other wiring connections and test all conveyor electrical controls for proper operation.
9. Check that all conveyor safety guards removed during the installation have been replaced.
10. Check that tools and all installation materials have been removed from the conveyor.
11. Check that the reducer lubricant is up to the oil level plug. If the reducer requires additional lubricant, refer to the manufacturer’s tag attached to the reducer before adding.  
Note: Before reinstalling the oil level and fill plugs, treat the plug threads to prevent oil leakage.
12. Review Safety Precautions listed in this Section. See “Safety Precautions” on page G - 2.

---

## Belt Tracking

At this point, the conveyor is properly installed, all sections are aligned, and all carrier rollers are level and square with the frame. The belt is installed with all pulleys, snub, and return rollers at right angles to the conveyor frame, and all pre-start-up precautions observed. Now you are ready to track the belt.

---

**WARNING:** Belt tracking is performed while the conveyor is running and is dangerous. Only trained and qualified personnel must perform the belt tracking function. The personnel must be instructed to always be alert for any unsafe condition and to use extreme care when tracking the belt.

---

## Principles of Belt Tracking

You must understand the principles of belt tracking in order to properly track the belt:

- **Crowned Pulleys** - Belts connecting parallel shafts tend to run toward that part of the pulley which is largest in diameter. Therefore, pulleys are crowned to keep the belt on center.
- **Taut Belt** - The belt must be sufficiently tensioned to not slip on the drive pulley. **DO NOT** overtighten.
- **Parallel Shafts** - If the pulley shafts are not parallel, the belt will creep toward the side where the shaft centers are closest. For pulley adjustment, see Figures G - 19 through G - 21.

## Belt Tracking Instructions

1. When first tracking the belt, station qualified personnel at each end of the conveyor to observe possible belt tracking problems.
2. It is seldom possible to make pulley shafts perfectly parallel. Corrective adjustments must be made with the snub rollers. See Figure G - 26 through Figure G - 28.
3. A common mistake is to adjust the end pulleys for any belt tracking problem. It is proper to adjust the end pulleys only for mis-tracking on the pulley at the discharge end of the conveyor. See Figure G - 19.
4. Note that the belt creeps toward the side of the pulley or snub roller that it touches first. Adjustments should be made accordingly. See Figure G - 18 through Figure G - 21.
5. All adjustments should be slight and you must allow sufficient time for the belt to react to the adjustment, (especially if the conveyor operates at slow speeds). Multiple revolutions of the belt are required for the belt to reach equilibrium.

## Examples of Belt Tracking

As shown in Figure G - 19 through Figure G - 21, the belt always creeps to the right side of the conveyor. The right side of the conveyor is the side to your right when you are facing in the direction of forward travel of the product. See Figure G - 17. For reversible conveyors, forward travel is that direction of travel which is used to convey the largest amount of product.

The terminal ends are identified by their location in relation to the forward direction of product travel.

The conveyor's infeed end (forward travel) is referred to as the "tail" end, and the discharge end is the "head" end. See Figure G - 18.

On reversible units, the head and tail end designations will remain the same for both directions of travel once the forward direction is established.

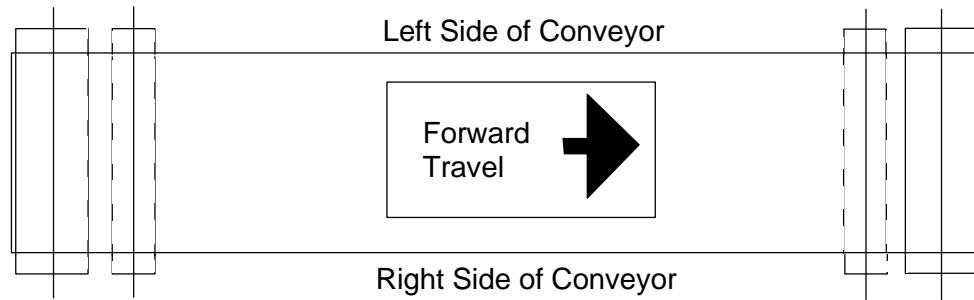

Figure G - 17 Direction of Travel

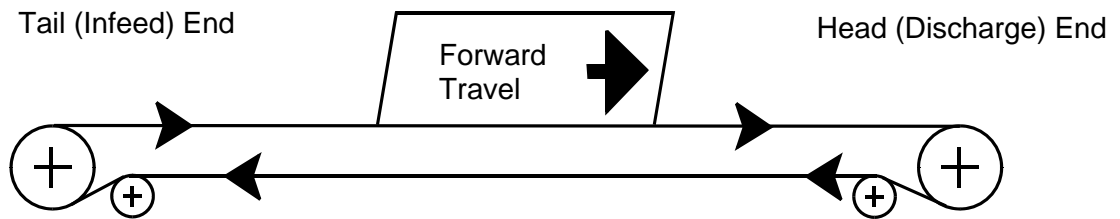

Figure G - 18 Product Travel From Tail End to Head End

During forward product travel, if the belt creeps to the right on the head pulley (drive/idler), adjust the right side of the head pulley in direction "F" (Forward) and/or the left side in direction "R" (Rearward). See Figure G - 19.

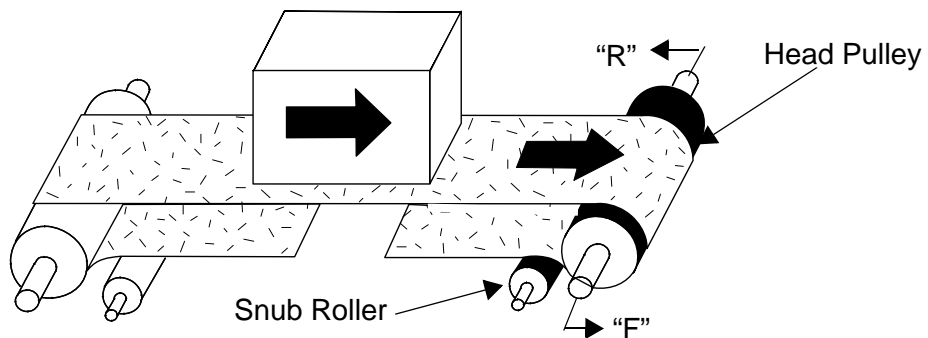

Figure G - 19 Adjusting the Right Side of the Head Pulley

During forward product travel, if the belt creeps to the right on the tail pulley, adjust the right side of the tail end snub roller in direction "R" and/or the left side in direction "F". See Figure G - 20.

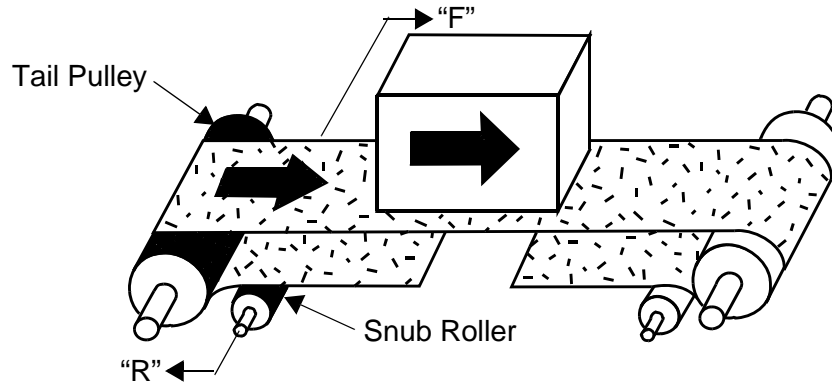

Figure G - 20 Adjusting the Right Side of the Tail End Snub Roller

During forward product travel, if the belt creeps to the right at the upper bend, adjust the right side of the upper bend roller A in direction "F" and/or the left side of upper bend roller B in direction "R". See Figure G - 21.

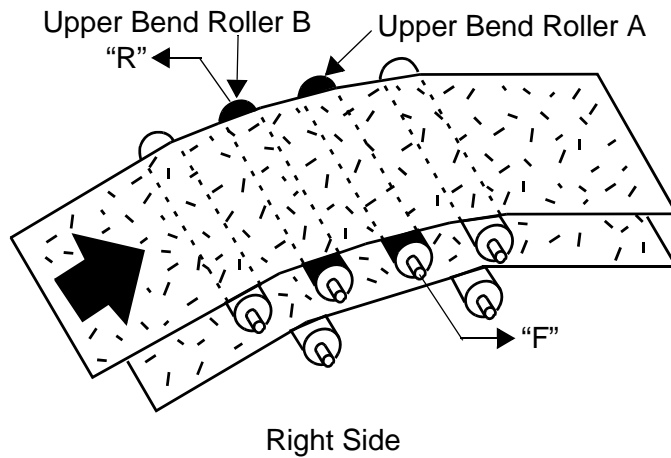

Figure G - 21 Adjusting Upper Bend Roller for Tracking the Upper Run of Belting

Proper installation is a key factor in tracking the belt at the Upper Bend. Make certain the unit is level (from side-to-side) and that both sides are adjusted evenly. See Figure G - 22.

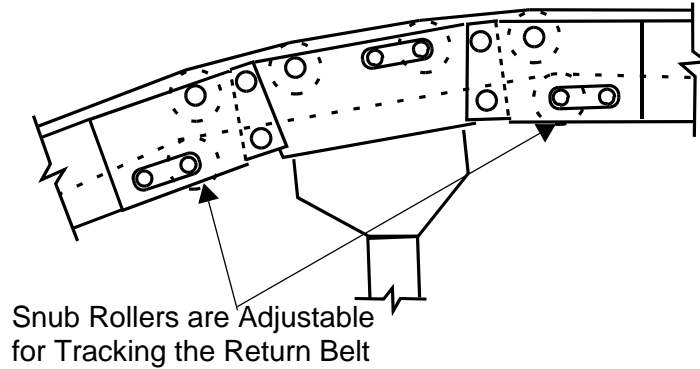

Figure G - 22 Adjusting Upper Bend Snub Rollers for Tracking the Return Run of Belting

In Figure G - 23 and Figure G - 24, the direction of product travel is not mentioned. This is necessary as the Intermediate Drives are reversible and may be installed as either right-hand or left-hand assemblies.

With the belt travel as shown in Figure G - 23, if the belt creeps to the near side of the drive and take-up pulleys, adjust the near side of snub roller A in direction "R" and/or the far side in direction "F."

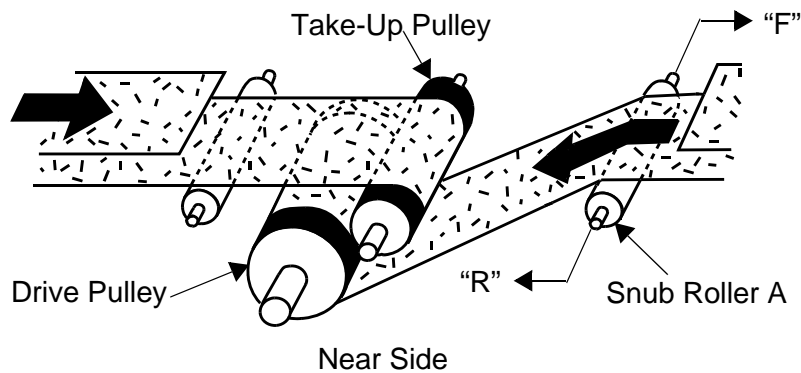

Figure G - 23 Adjusting the Near Side of the Snub Roller

With the belt travel as shown in Figure G - 24, if the belt creeps to the near side of the drive and take-up pulleys, adjust the near side of snub roller B in direction "R" and/or the far side in direction "F."

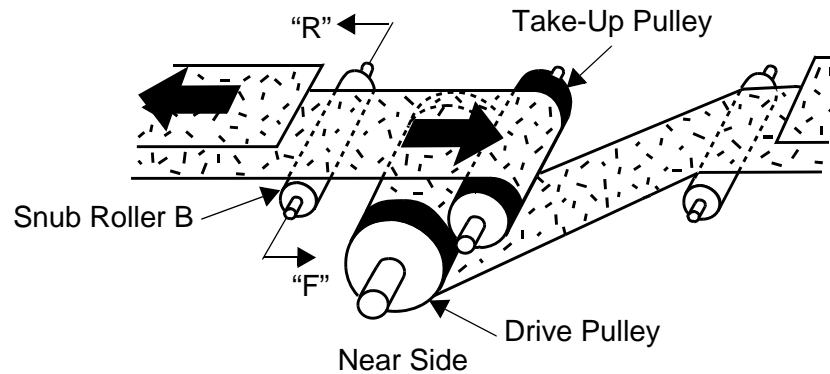

Figure G - 24 Adjusting the Near Side of Snub Roller B

### Belt Tracking Check List

1. Check the entire belt path for serious tracking problems that require immediate attention.
2. Watch the belt's position at a given point for at least one complete rotation. If the belt does wander off center and then returns back to the center position, there is no need to make any adjustments. When the belt wanders off center, it is caused by camber in the belt length which will tend to straighten out in time.
3. (Roller Bed Only) If the upper run of the belt moves off center in a particular section, check that section to see if the rollers are square to the frame rails. If they are not at right angles with the frame, the section(s) must be straightened.
4. If the upper run of belt runs "off-center" the full length of the conveyor, first make adjustments of the Snub Roller as shown in Figure G - 20. Then, if necessary, adjust the End Pulley as shown in Figure G - 19.
5. Observe the belt's return run and its position on each return roller. Adjust any roller that causes the belt to move off center.
6. If the belt mis-tracks at the Upper Bend Unit, adjust the Upper Bend and/or Snub Rollers as shown in Figure G - 21 and Figure G - 22.
7. If the belt mis-tracks at the Intermediate Drive, adjust the Snub Roller proceeding the drive as shown in Figure G - 23 and/or Figure G - 24.
8. On reversible unit, first track the belt in the forward direction of travel, then reverse the conveyor and repeat the tracking steps.



## Adjusting Belt Tension

Tension the belt by adjusting the Take-Up Pulley. See Figures G - 25 through G - 27. The adjustments must be made equally on both sides and in small increments.

Adjust the Take-Up Pulley so that the belt tension is just tight enough to prevent the belt from slipping on the Drive Pulley. Excess tension will reduce the life of the Belt, Lacing, Snub Rollers, and Pulley Bearings.

---

**WARNING:** Adjustment of the Take-Up Pulley may require the chain guard to be removed. When adjusting, be careful to stay clear of the chain and drive components.

---

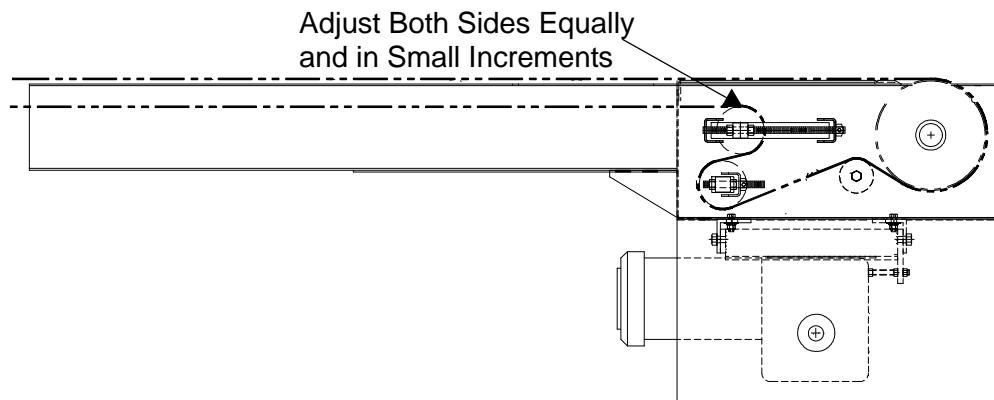
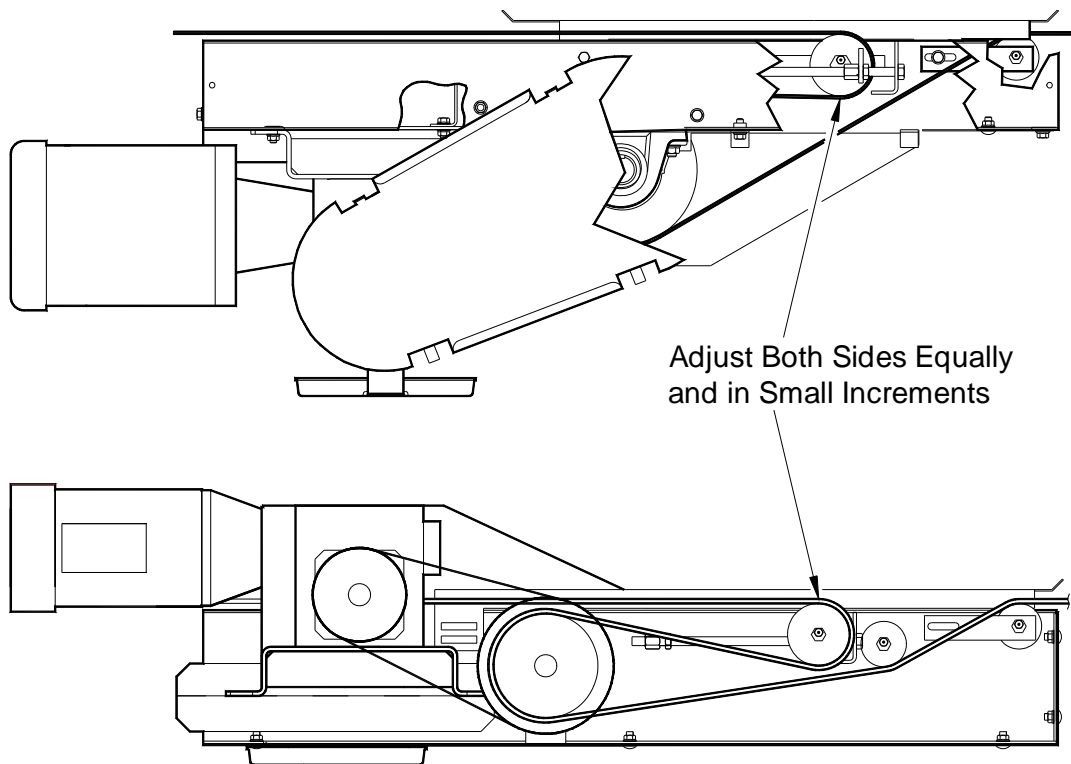

Figure G - 25 End Drive Take-Up



8100FKI011a

Figure G - 26 Intermediate Drive

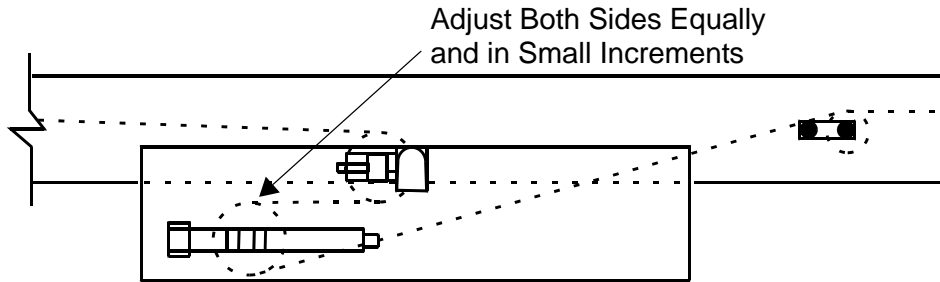

Figure G - 27 Auxiliary Take-Up

### Adjusting Snub Rollers

The assembly of the clips, bolts, etc. is common for all End Drive Take-Ups and Idlers. To adjust, loosen both the bolt and nut on one side and shift the roller as required.

End Drives also have a snub roller. Belt adjustment requires that the flanged hex bolt (A) be loosened before the roller can be shifted. See Figure G - 28.

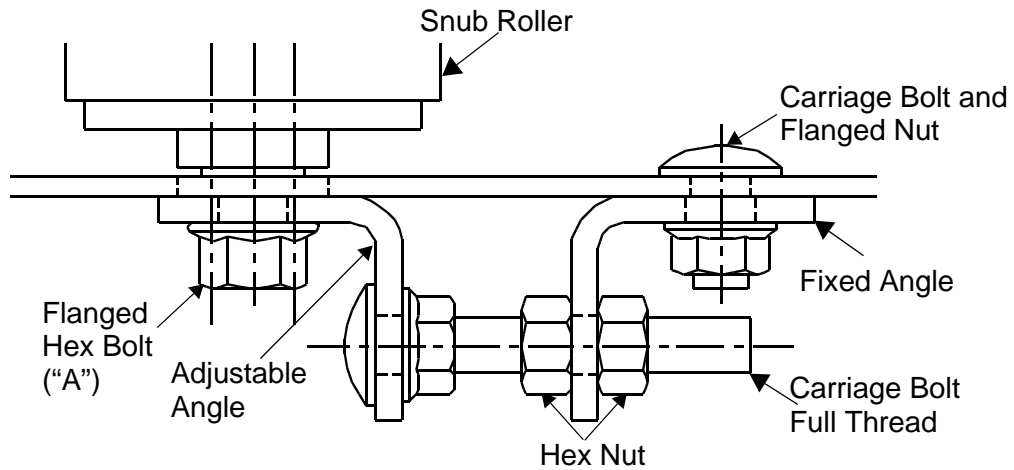

Figure G - 28 Adjustable Snub Roller Assembly

---

## SECTION H: MAINTENANCE

### General

The recommended inspection and maintenance functions described in this Section apply to intermittent-duty conveyor applications. Additional functions may be required for continuous-duty operation or extreme environmental conditions.

### Maintenance Safety

---

---

**WARNING:** Maintenance must be performed only by qualified personnel who are trained in normal and emergency operations of the conveyor and who are knowledgeable of all safety devices, their locations, and functions.

Before performing maintenance on a conveyor, make certain that the conveyor's power disconnect is locked in the OPEN position and tagged to prevent accidental or unexpected application of power.

Do not perform maintenance while the conveyor is running unless specifically instructed to do so in this manual.

Note: Other than belt tracking and checking chain tension, it is NOT necessary to have the conveyor turned ON to perform any of the work described in this section.

---

---

Before restarting a conveyor:

- Remove all foreign objects from the conveyor.
- Be sure that all guards and safety devices are properly installed and working.
- Make sure that all persons are clear of the conveyor and are aware that the conveyor is about to be restarted.

### New Installations

All newly installed equipment should be inspected frequently and serviced as needed during the first 40 hours of operation. See "Initial Start-up and Run-in Period" on page H - 1. Thereafter, an appropriate maintenance program should be established and followed. See Table H 1.

### Maintenance Logs

Maintenance logs should be kept on all conveyor installations. Each log sheet should show:

- The date when an Inspection or Maintenance function was performed
- Details of the Inspection or Maintenance function
- Names of personnel performing the Inspection or Maintenance function

### Initial Start-up and Run-in Period

#### Chain and Sprockets

Check the drive chain tension daily for the first week of operation, then monthly. Refer to the "Chain Maintenance" label on the inside of chain guard.

---

---

**WARNING:** Chain tension must be checked while the conveyor is running with the chain guard removed. When checking, be careful to stay clear of the chain and drive components.

---

---

## Power Unit Reducer

Grove and Reliance reducers are supplied with “lifetime” synthetic lubricants (Mobile SHC-634) that do not need to be changed after the unit is put into service.

**Note:** All reducers tend to run hot when first put into operation until the maximum break-in efficiency is reached (approximately 120 hours).

## Scheduled Inspections and Maintenance

Intervals indicated for performing inspections and maintenance should be considered for an 8 hour per day operation. An application may subject the equipment to conditions that would necessitate more frequent maintenance. This may best be determined by performing maintenance more frequently when the conveyor is first put into operation, and then lengthening the intervals based on experience.

Table H 1: Scheduled Maintenance

	Components	Item Check									
		Lubrication	Oil Level	Tension	Wear	Alignment	Fasteners	Set Screws	Proper	Physical	Operation
Weekly	Belt			X	X	X				X	
	Belt Lacing									X	
	Carrier/Belt Return Rollers									X	X
	Electrical Devices								X	X	X
	General Structure						X			X	X
	Power Unit - Reducer		X								
	Safety Guards/Devices								X	X	X
Monthly	Bearings - External						X	X		X	
	Drive Chains and Sprockets	X		X	X	X	X	X		X	
	Timing Belts and Sprockets			X	X	X	X	X		X	X
	Take-up/Idler Pulleys									X	X
	Power Unit - Motor						X			X	
	Power Unit - Reducer						X			X	
	Pulley Lagging									X	
	Supports and Hangers						X			X	
Semi Annually 1040 hrs.	Bearings - External	X									
	Power Unit - Motor	X									
	Power Unit - Reducer	X	X								

---

## Daily Inspections

General walk-through inspections of the conveyor equipment during daily plant operation is recommended. Listen for unusual noises and carefully observing the system. For continuous duty applications, conduct conveyor inspections once each shift.

Frequently check equipment safety guards, warning signs, lights, and alarms associated with the operation of the conveyor system and keep them in good condition to ensure the safety of all plant personnel. Any unusual conveyor noise, oil leaks, and operational problems should be immediately reported and promptly corrected.

## Weekly Inspections

### Belting

Check that the belt is tracking properly along the entire conveyor length. Make appropriate adjustments of snub rollers, etc. If required; check that the belt tension is sufficient to prevent the belt from slipping on the drive pulley under the maximum required load. Remove any buildup of product spillage.

### Belt Lacing

Check the lacing for damage or protrusions which might cause damage to the conveyor or product. If the lacing needs to be replaced and the take-up permits, cut both ends of the belt square and re-splice. If the take-up does not permit, cut and lace in a short length of belting (1'-0" long minimum).

### Carrier and Belt Return Rollers

Check that all rollers are in place and turning freely. Remove any buildup of dirt and/or product spillage. Take care in keeping cleaning materials from coming in contact with the ball bearings.

### General Structure and Operation

Check the conveyor's physical condition, looking for loose fasteners, damaged or wearing components. Listen for unusual noises such as squeaking bearings, chains jumping sprockets, etc.

Check that the conveyed product travels along the length of the conveyor without obstruction of hesitation.

### Power Unit Reducer

Check for signs of oil leakage on the floor and/or in the drip pan. If leakage persists or the amount of leakage is significant, repair or replace the unit. Until corrections are made, closely monitor the unit's oil level.

### Safety Guards and Devices

Check that the safety guards, warning signs, light, and alarms are in place and in proper working condition. Check that all Emergency Stop pull-cords and/or push buttons are functioning properly.

### Electrical Devices

Photocells, proximity sensors, limit switches, etc. should be periodically inspected and adjusted as needed. Lenses and reflectors on photoelectric devices should be wiped clean

---

on a daily basis. For additional maintenance provisions, refer to the appropriate vendors instructions provided.

## Monthly Maintenance

### External Bearings

Check that all mounting bolts, set screws, etc., are securely tightened, and that no lubricant is coming out of the seals. Listen for any unusual noises.

### Internal Bearings

Check that the bearings are fully-pressed into the roller tube, and that the lubricant is not coming out of the seals. Listen for any unusual noises.

### Power Unit Motor

Remove any build-up of dirt/dust around the motor vent openings. Check that all mounting bolts are securely tightened and that the motor lead wires are securely connected.

Unless specified, wick-oil sleeve bearings should be lubricated every 2000 to 4000 hours. After the first 4000 hours of operation lubricate with 3 or 4 drops of light grade mineral oil or SAE10W motor oil. Refer to the motor lubrication plate or vendors instruction tag(s).

### Power Unit Motor/Brake

Due to normal wear, the brakes require periodic inspection and adjustment. For instructions, refer to the vendors installation and maintenance manual or contact the manufacturer for additional information.

### Power Unit Reducer

Check the oil level while the unit is warm, but not running. If required, add oil through the "fill" hole until the oil begins to run out of the "oil level" hole. All standard reducers are filled by the manufacturer with a synthetic gear lubricant. When replenishing the oil, be sure to use the same brand and type. DO NOT MIX lubricants. For further information, refer to the instruction tag attached to the unit.

To prevent oil leakage, apply Teflon tape or Permatex to the threads of the fill plug and oil level plug before reinstalling. Properly install and tighten the plugs before putting the unit back into operation.

### Power Unit Sprockets

Check sprocket alignment by placing a straight edge across the face of the sprockets simultaneously.

Inspect chain sprockets for need of lubrication. If required, lubricate the chain lightly with SAE 30 oil. DO NOT use grease. Also check teeth for wear. Realign if required,

### Power Unit Chains

Lubricate and check tension per instructions given on the "Chain Maintenance" label located on the inside of the chain guard. Remove any dirt or dried oil with a kerosene soaked rag.

## Power Unit Timing Belts

Adjust reducer to remove any belt slack and achieve a snug belt tension.

Use the following steps to check belt tension:

1. Measure the center distance between the driver and driven sprockets to determine the belt span length. See Figure H - 1.
2. Determine the correct deflection for the span as follows: Deflection = Span Length ÷ 64.
3. Use a spring-scale tension checker (possible source Browning) to determine the force required to produce the required deflection. See Table H 2.

Table H 2: Timing Belt Deflection/Force

Belt		Deflection
Pitch	Width	Force
8mm	12mm	7 lbs.
	22mm	15 lbs.
	35mm	20 lbs.
Pitch	42mm	23 lbs.

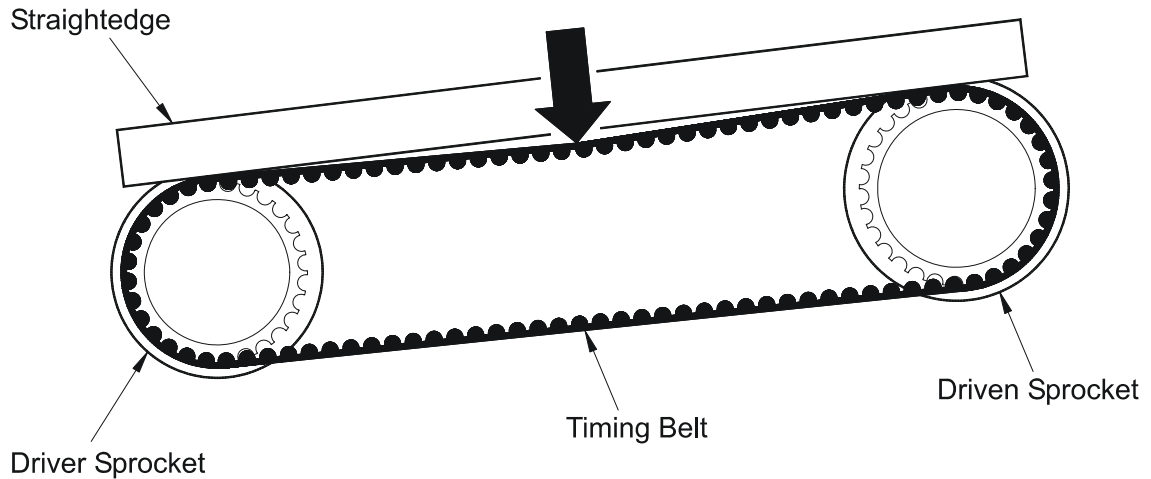

8100FKI013a

Figure H - 1 Measuring Timing Belt Deflection

### Drive Sprockets

Check the alignment by placing a straight-edge across the face of both sprockets simultaneously. Also check for wear on the sprocket teeth and side bars of the chain. If loose, tighten the sprocket fasteners.

### Drive Pulley and Lagging

Check the pulley alignment and make certain that all mounting bolts are securely tightened. Check for worn or damaged lagging on the drive pulley. Repair or replace as required.

---

## Supports and Hangers

Check that all floor supports and/or ceiling hangers are in good physical condition and have not been damaged. Check that all fasteners are securely tightened and that none are missing.

## Semi-Annual Maintenance

### Power Unit Motor

Units up to 5 HP are lubricated for life. For 7.5 HP motors, refer to the manufacturer's motor lubrication plate or operating instruction tag wired to the motor.

### Power Unit Reducer

Check that all fasteners are secure.

### External Pulley Bearings

All external bearings have lubed-for-life bearing cartridges, and do not require periodic lubrication.

If desired, the bearings may be re-lubricated using the grease-fitting that is provided in all bearing housings. Once grease is added, the bearing must be re-lubricated every 6 months with a lithium based ball bearing grease or compatible grease conforming to NLG1 Grade 2 consistency.

Add the grease slowly and sparingly while the pulley is rotating until a slight showing of grease forms around the seals. **DO NOT OVER LUBRICATE.** Too much grease may damage the seals. If a bearing is over greased; remove the fitting to allow the excess grease to escape. Replace the fitting and wipe clean before putting the conveyor back into operation.

### Internal Bearings

Check that the bearings are fully-pressed into the roller tube, and that the lubricant is not coming out of the seals. Listen for any unusual noises.

**Note:** For 2-1/4" diameter knife edge pulleys lubricate with Valvoline #633 every 1000 hours.



## Replacing the Belt(s)

When replacing the belt(s), it may be beneficial in certain applications to splice the belt on a bias to reduce noise. When the belt is spliced on a bias, Intelligrated engineering requires the angle of the splice to be less than 7 degrees. Use the table below as a guide for common belt widths and dimensions. Each end of the belt must be cut at the exact same angle to ensure proper belt tracking. Be sure to take the offset measurement before trimming 1/4" from the corners, so as not to exceed the maximum bias angle.

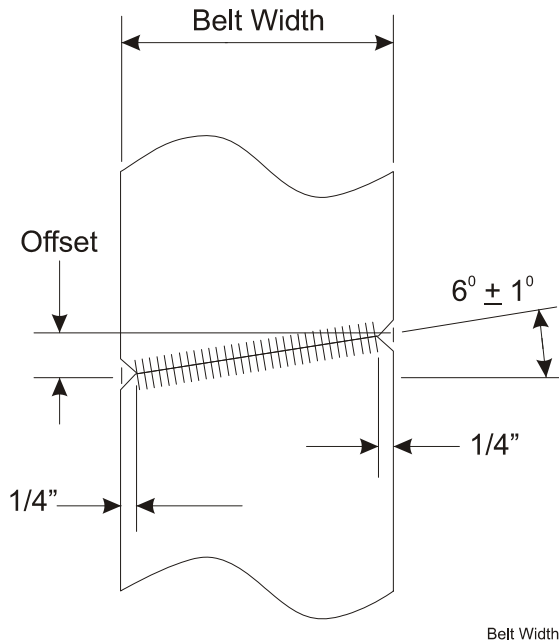

Common Belt Widths	Offset Dimension for 6 Degree Bias
12"	1-1/4"
18"	1-7/8"
24"	2-1/2"
30"	3-1/8"
36"	3-13/16"

## Troubleshooting

Basic troubleshooting provisions are outlined below. For troubleshooting for the specific conveyor system installed, always check the maintenance information. Basic troubleshooting is outlined in Table H 3.

**CAUTION:** Do not clear jams or reach into any unit before first turning off the equipment power source(s) and making certain that all moving parts are fully stopped. To avoid personal injury or equipment damage, lockout and tagged the conveyor operation control(s) before attempting to correct any malfunction.

Table H 3: Basic Troubleshooting Problems and Solutions

Problem	Cause	Solution
Conveyor does not start.	Electrical power shut off or control circuit NOT energized.  System control devices (photo-cells, limit switches, etc.) out of adjustment or defective.  Motor overload block open.	Check that system control panel(s) are energized. Be certain emergency stop devices are not activated.  Adjust or replace.  Check conveyor drive system and overload sizing before resetting.
Conveyor shuts off.	Accumulation photocell or other control device(s) actuated or defective.  Emergency stop activated.  Power or component failure at system control center.  Motor overload.	Check conveyor accumulation or obstruction of control device; replace control device if defective.  Correct condition and reset according to control logic.  Refer to vendor manuals.  Check conveyor drive system and overload sizing before re-starting.
One part of belt creeps to one side.	Belt ends not cut square.	Cut the belt ends perfectly square using a T-square.

Table H 3: Basic Troubleshooting Problems and Solutions (Continued)

Problem	Cause	Solution
Entire belt creeps to one side.	<p>Improper loading of belt.</p> <p>Belt shifts to low side. The base structure or conveyor frame is not level or is crooked.</p> <p>Alignment of pulleys; drive, tail, pulleys, or snub rollers are out of line or not perpendicular with the center line of the conveyor.</p> <p>Underside of the belt is dirty.</p>	<p>Center the product on the belt. Load in direction of travel.</p> <p>Stretch a string along the edge of the frame, check alignment of the frame and correct. Next, check the level of support structure.</p> <p>Use a T-square against the edge of the conveyor to recheck and square the pulleys.</p> <p>Remove foreign matter, because it creates a new crown on the pulley/roller face adversely affecting the tracking.</p>
Belt creeps to one side in head (discharge) pulley area.	Head pulley is out of alignment (not perpendicular with the center line of the conveyor).	First, adjust the snub roller. Second, realign the head pulley by advancing (belt travel direction) the end of the pulley to which the belt has shifted.
Belt creeps to one side in tail (infeed) pulley area.	Tail pulley is out of alignment (not perpendicular with the center line of the conveyor).	First, adjust the snub roller. Second, realign the tail pulley by advancing (return belt travel direction) the end of the pulley to which the belt has shifted.
Belt wanders irregularly.	<p>The conveyor is over-belted. This results in the belt being too stiff to properly operate over the pulley diameters.</p> <p>Off center or improper loading.</p>	<p>Change to the proper belt or use pulleys with larger diameters.</p> <p>Correct loading procedure.</p>
Edge wear is excessive.	<p>Belt edges fold up on conveyor guards and frame.</p> <p>Belt shifts to opposite side and rubs excessively due to side loading.</p> <p>Refer to previous Belt Problems to eliminate edge rubbing.</p>	<p>Remove the rough areas on the conveyor guards or frame.</p> <p>Loading in direction of belt travel will improve this condition.</p>

Table H 3: Basic Troubleshooting Problems and Solutions (Continued)

<b>Problem</b>	<b>Cause</b>	<b>Solution</b>
Belt fasteners pulling out.	Fasteners are incorrect size	Re-lace the belt with proper size fasteners.
	Too much tension on belt.	Relieve tension until belt will run without slipping on the drive pulley.
	Pulley diameters too small for the thickness of belt used.	Replace with larger diameter pulleys or thinner belt, if practical.

**SECTION I: PARTS IDENTIFICATION**

**General Information**

The purpose of this section is to identify parts for a quality preventative maintenance program and to minimize the chances for extended down time.

The following pages illustrate the location of these parts as they apply to each particular unit. Keep in mind that these illustrations only apply to the standard product line. These items will show on the bill-of-material as a coded item.

There will be items on the bill-of-material such as gearmotors, sprockets, chain, etc., that will show up on the price sheets only.

**Intermediate Sections**

**Roller Bed**

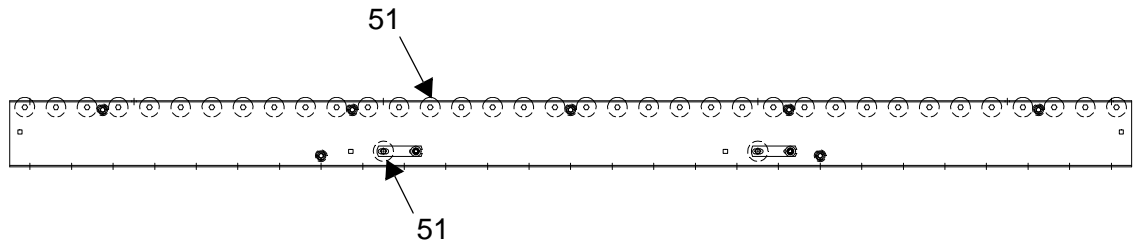

Figure I - 1 Roller Bed Intermediate Section

**Slider Bed**

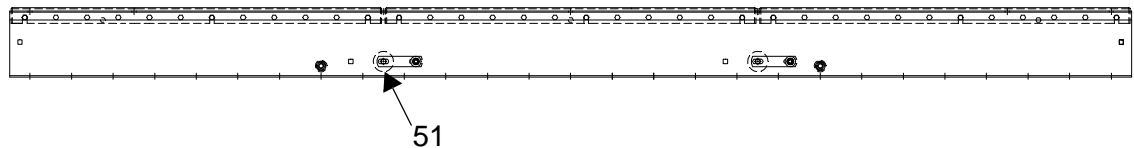

Figure I - 2 Slider Bed Intermediate Section

**Box Bed**

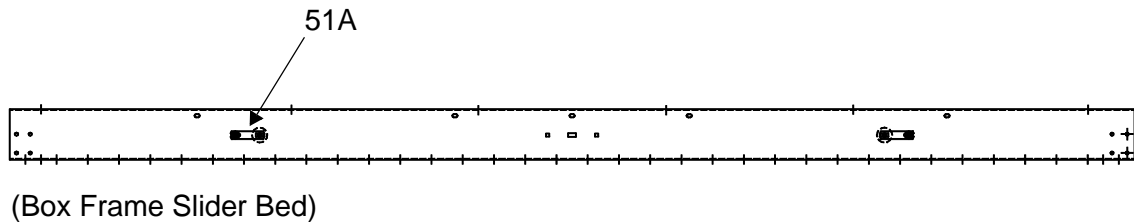

Figure I - 3 Box Bed Intermediate Section

## End Drives

### Series 400 with Take-Up

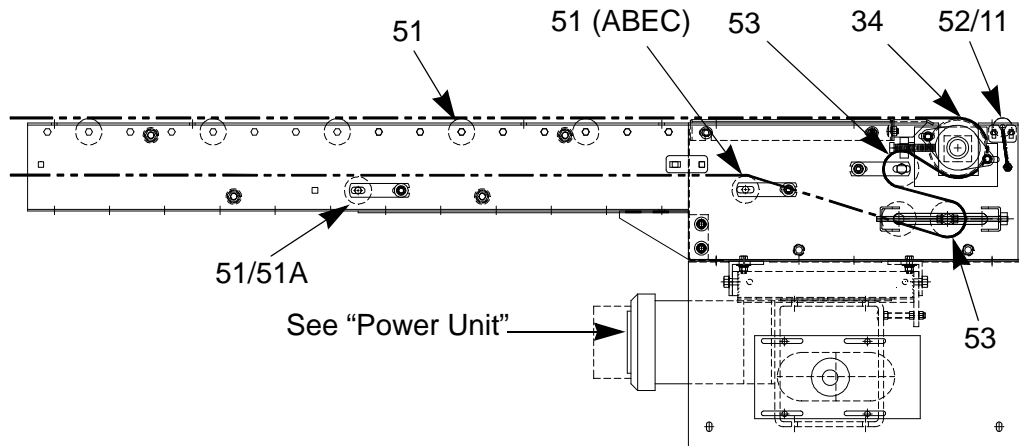
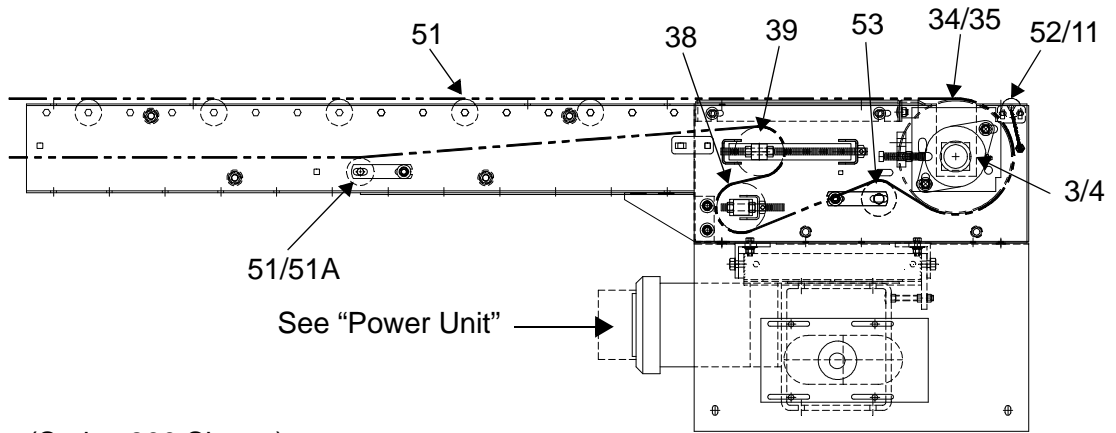

Figure I - 4 End Drive - Series 400 with Take-Up

### Series 600 and 800 with Take-Up



(Series 800 Shown)

Figure I - 5 End Drive - Series 600 and 800 with Take-Up

## End Idlers

### Series 400, 600, and 800

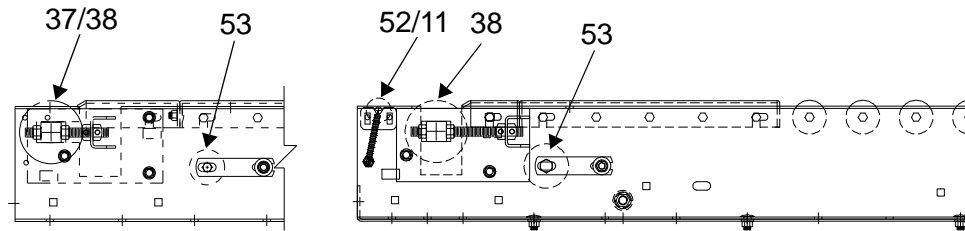

Figure I - 6 End Idlers - Series 400, 600, and 800

### Knife Edge Assembly

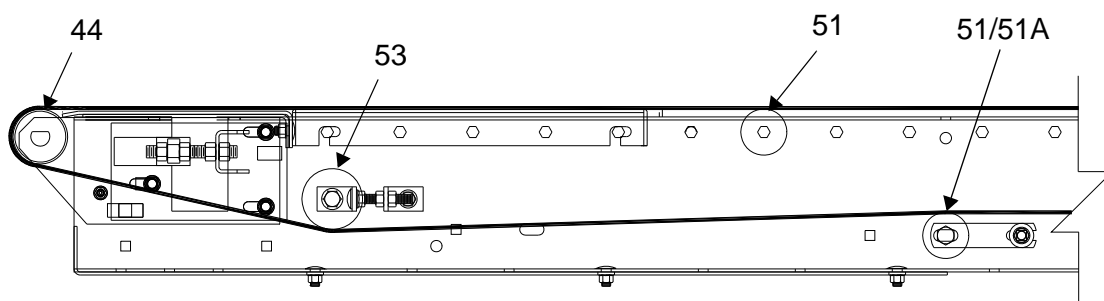
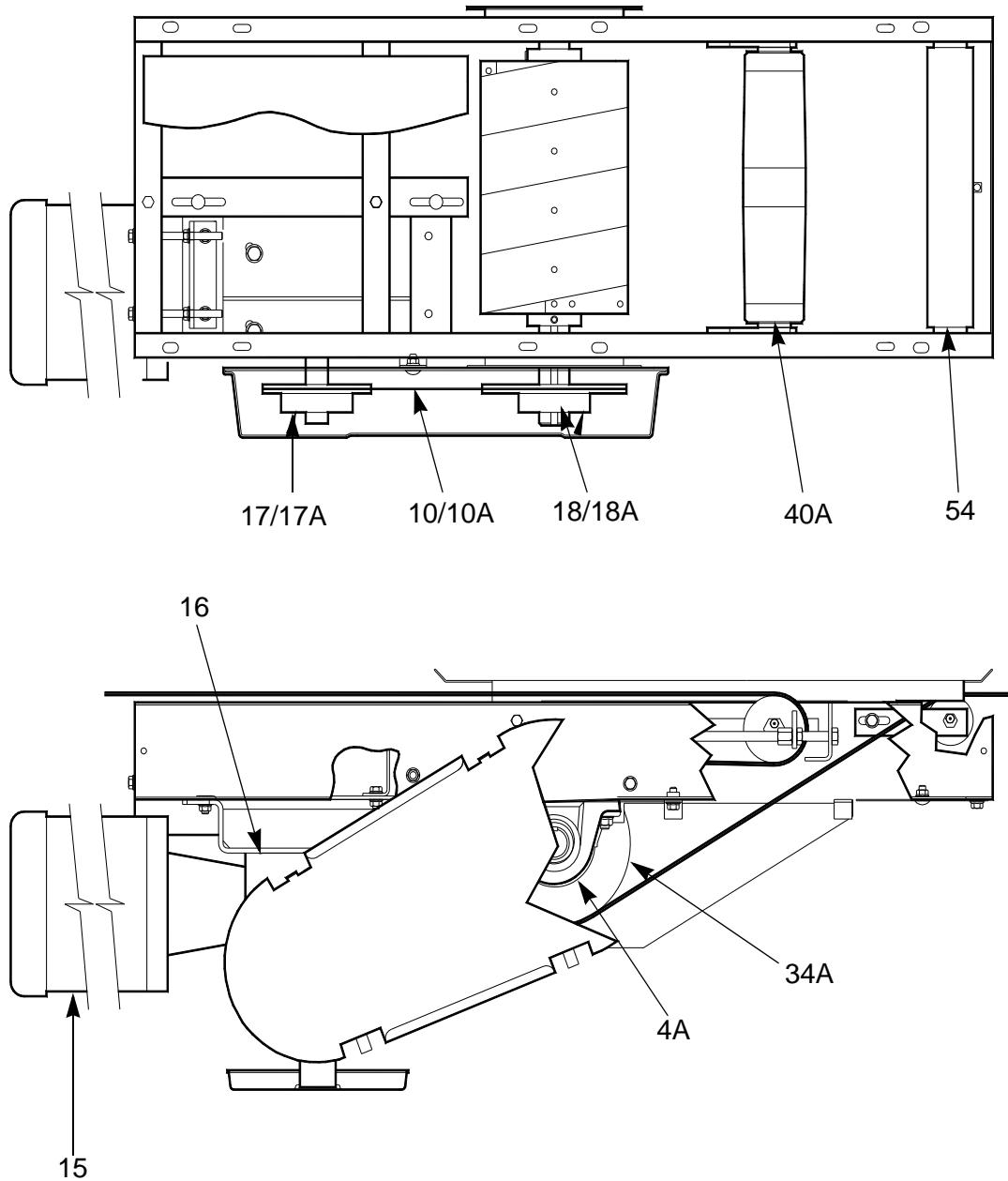

Figure I - 7 End Idler - Knife Edge Assembly

# Intermediate Drives

## SA2000 - Intermediate Section



8100FKI005a

Figure I - 8 SA2000 - Intermediate Section



SA2001 - Intermediate Section - Low Profile

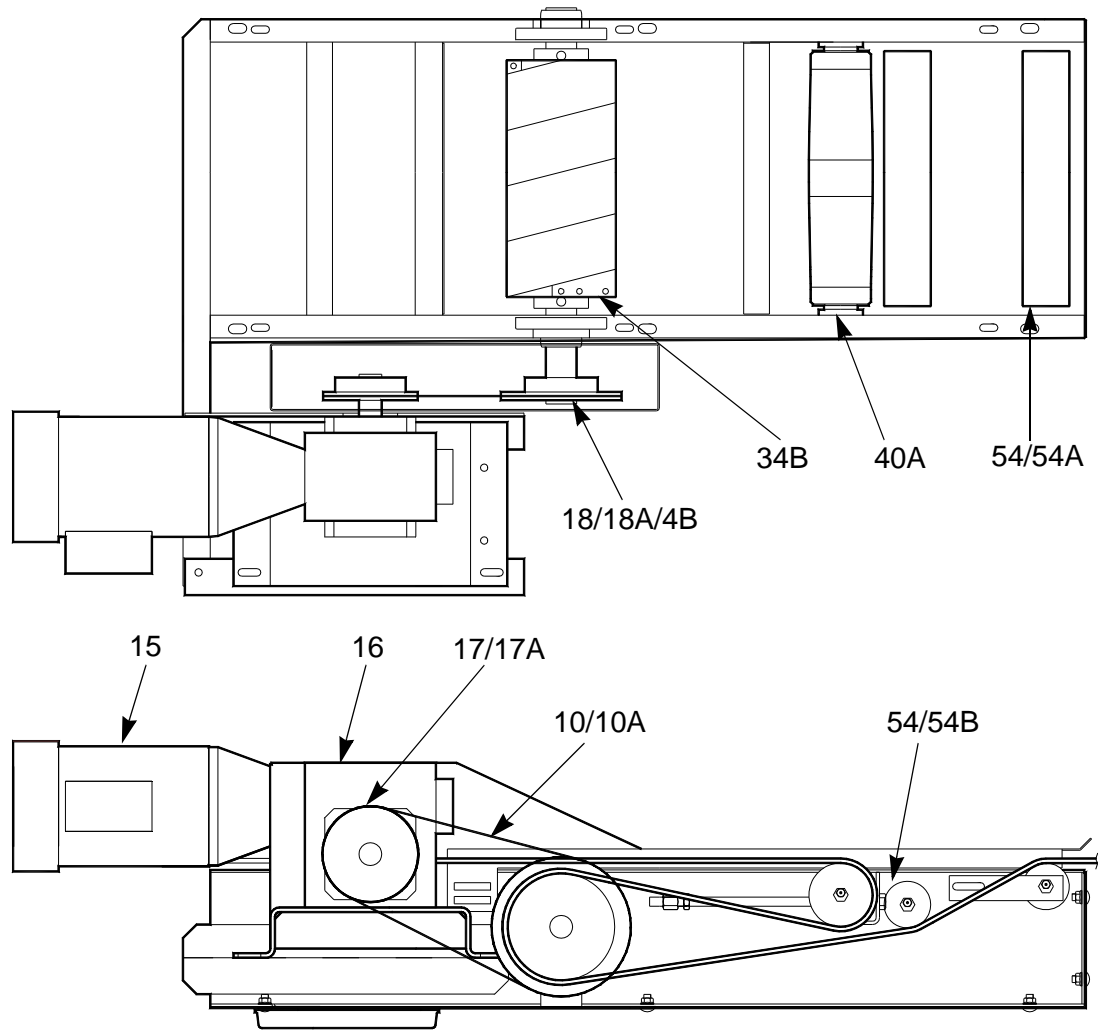

8100FK1006

Figure I - 9 SA2001 - Intermediate Section - Low Profile

**Auxiliary Take-Up Sections**  
**Manual (3.5" Pulleys)**

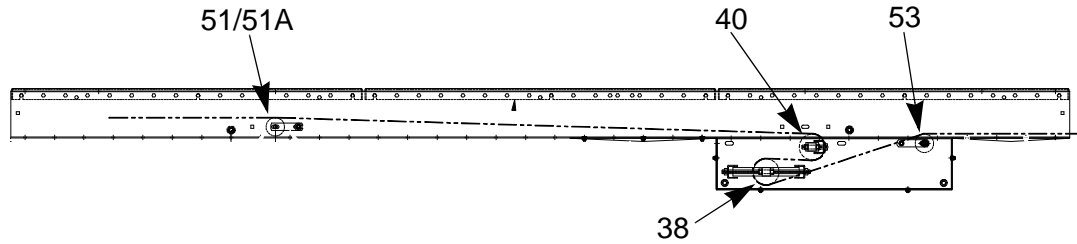

Figure I - 10 Auxiliary Take-Up Section - Manual (3.5" Pulleys)

**Manual (6" Pulleys)**

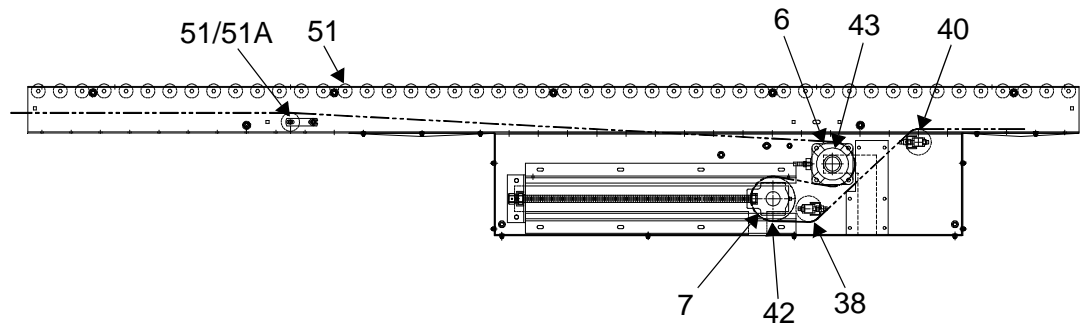

Figure I - 11 Auxiliary Take-Up Section - Manual (6" Pulleys)

**Automatic (Air) (6" Pulleys)**

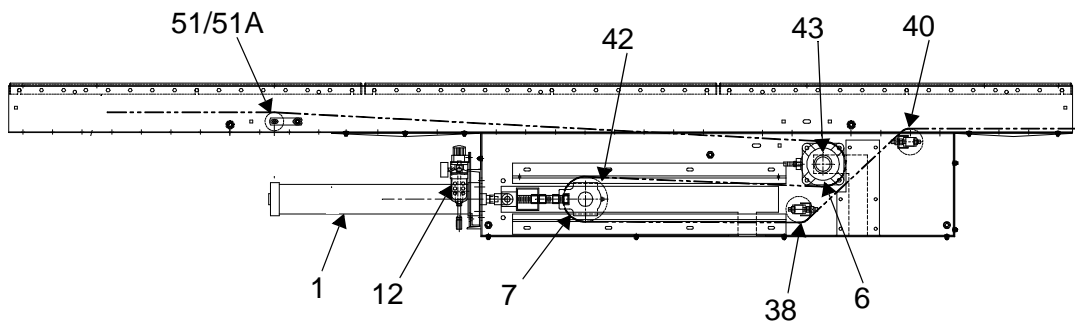

Figure I - 12 Auxiliary Take-Up Section - Automatic (Air) (6" Pulleys)

## Spring Take-Up

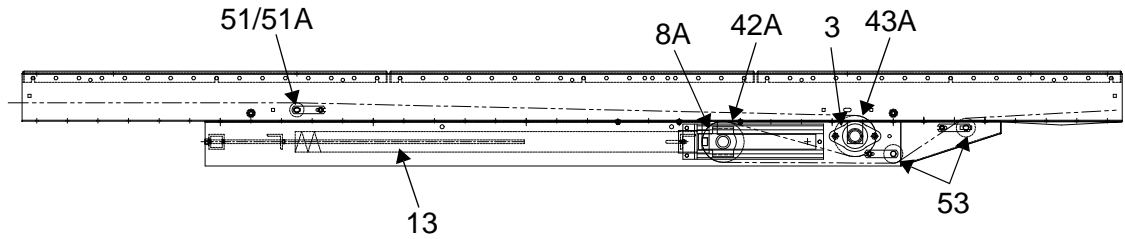

Figure I - 13 Spring Take-Up Section

## Upper Bend Sections

### 1.9" Rollers

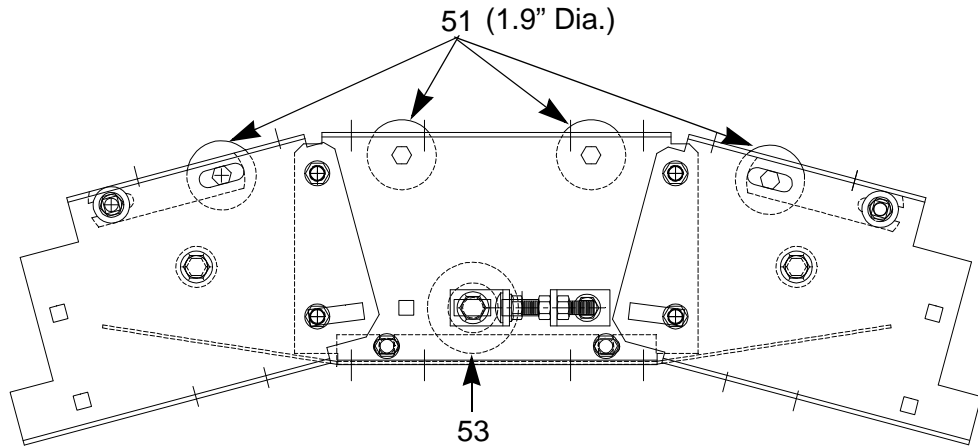

Figure I - 14 Upper Bend Section - 1.9" Rollers

### 2.5" Rollers

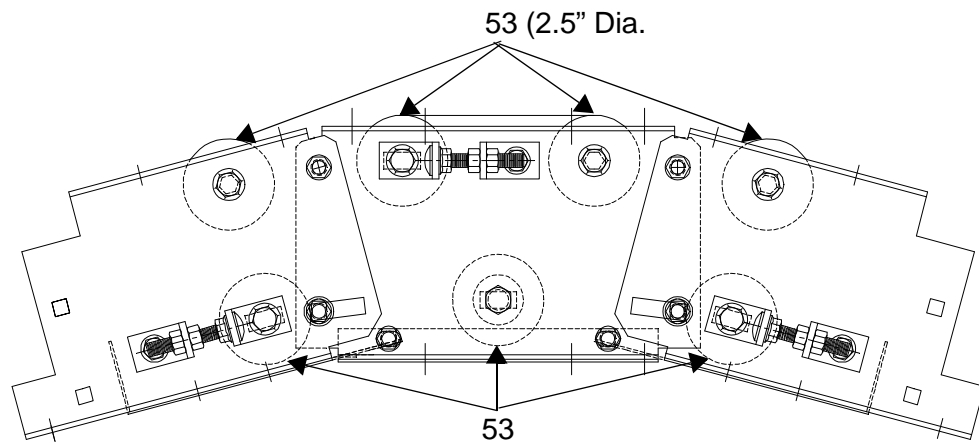

Figure I - 15 Upper Bend Section - 2.5" Rollers

## Power Units Under-hung Mount

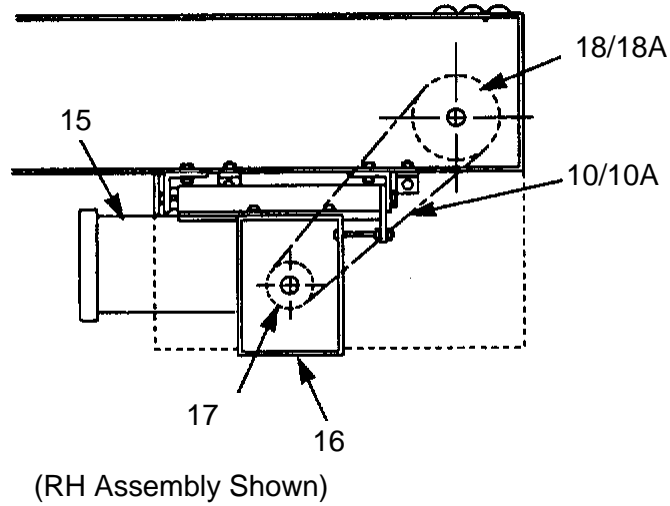

Figure I - 16 Power Unit - Under-hung Mount

## Side-Mounted

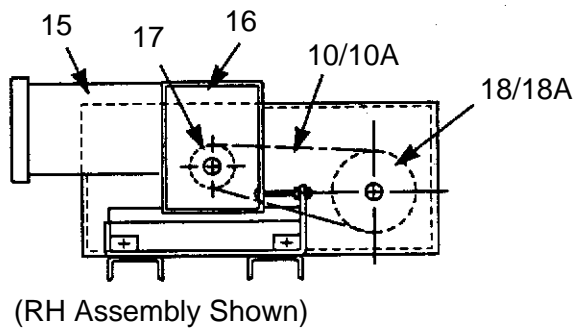

Figure I - 17 Power Unit - Side-Mounted

Table I 1: Reducer Assembly Designation

Under-hung Mount			Side-Mount		
Assembly	Brand	Designation	Assembly	Brand	Designation
Series 4/6/800 (RH-Shown) SA2000 (RH-Shown)	Grove	3	Series 4/6/800 (LH-Opp) SA2001 (LH-Opposite)	Grove	2
	Reliance	L1		Reliance	K1
Series 4/6/800 (LH-Opp) SA2000 (LH-Opposite)	Grove	2	Series 4/6/800 (RH-Shown) SA2001 (RH-Shown)	Grove	3
	Reliance	K1		Reliance	L1

## Driven Jackknife

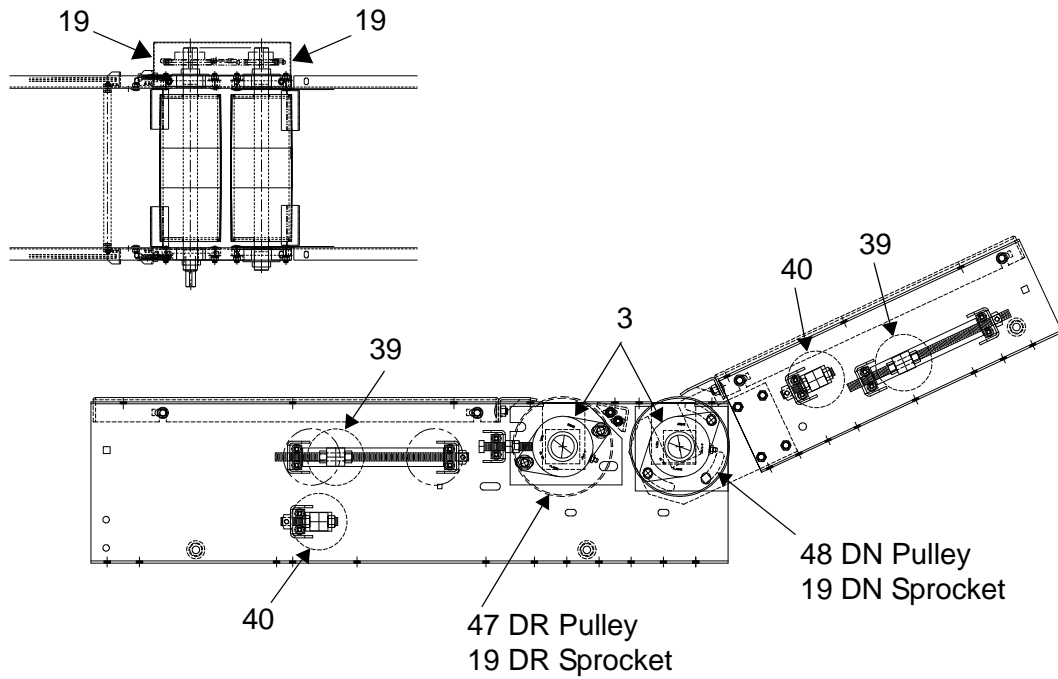

Figure I - 18 Driven Jackknife

## Non-Driven Jackknife

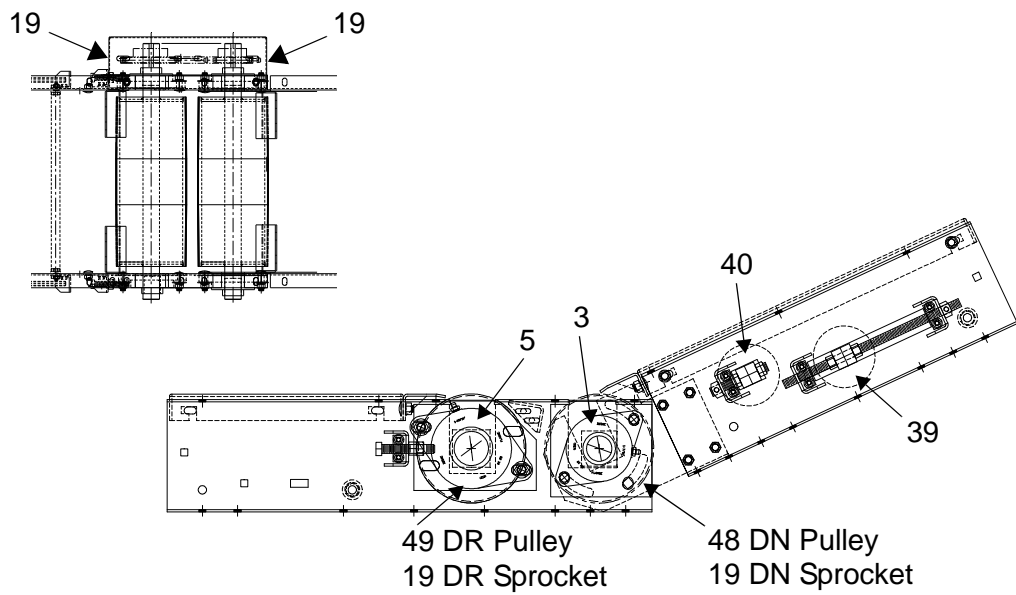

Figure I - 19 Non-Driven Jackknife

# Power Feeders

## Incline

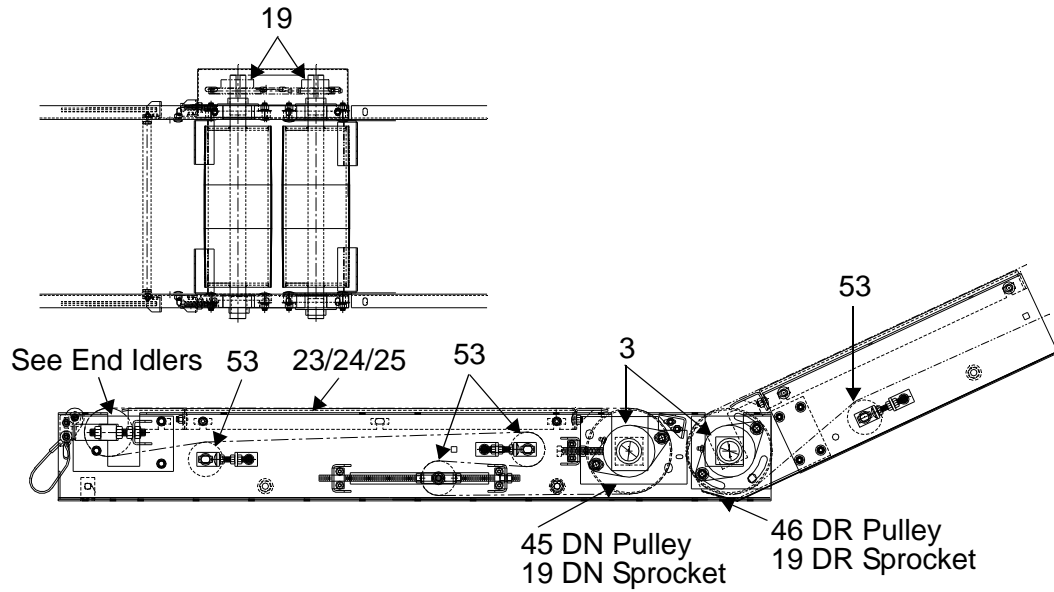

Figure I - 20 Power Feeder - Incline

## Decline

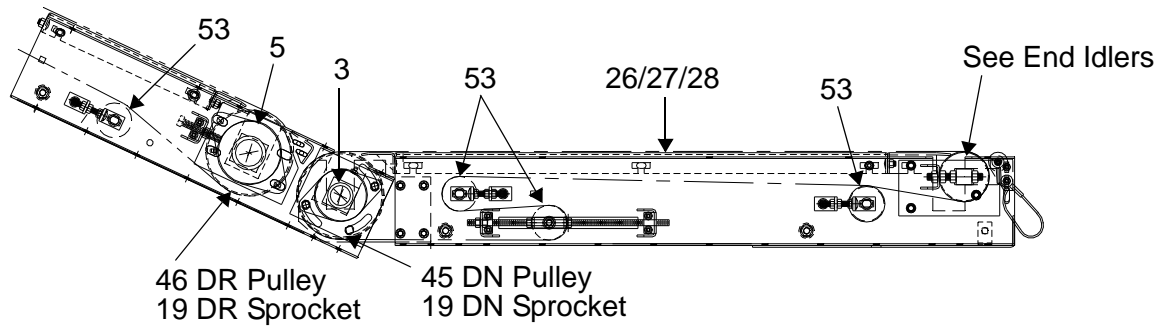

Figure I - 21 Power Feeder - Decline

---

Reversible

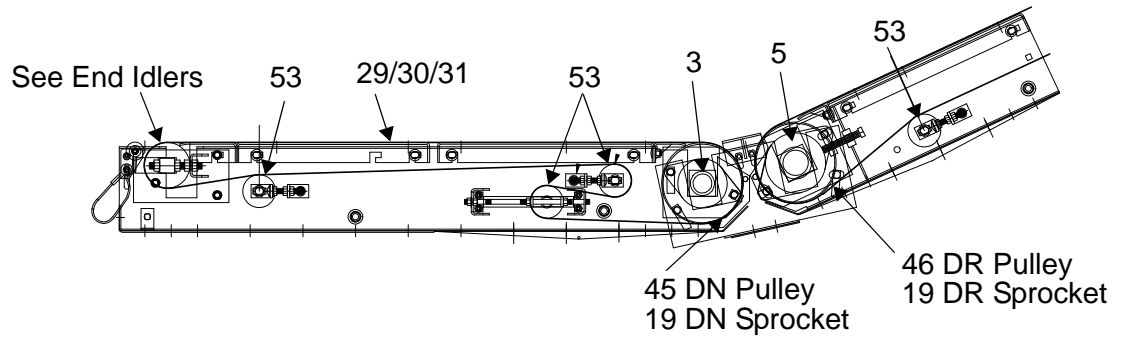

Figure I - 22 Power Feeder - Reversible

## Non-Width Related Parts

Key No.	Part Description	Part Number
1	Air Cylinder	27-2832
2	Bearing, 2-Bolt Flange, 1-3/16" BR - Pressure Lubricated	40-0985
3	Bearing, 2-Bolt Flange, 1-7/16" BR - Pressure Lubricated	40-0987
4	Bearing, 2-Bolt Flange, 1-11/16" BR - Pressure Lubricated	40-0990
4A	Bearing, 2-Bolt Flange, 1-11/16" BR - Pressure Lubricated (SA2000)	7522411
4B	Bearing, Pillow Block, 1-11/16" BR - Pressure Lubricated (SA2001)	7712387
5	Bearing, 2-Bolt Flange, 1-15/16" BR - Pressure Lubricated	40-0995
6	Bearing, 4-Bolt Flange, 1-15/16" BR - Pressure Lubricated	40-0970
7	Bearing, Take-Up, 1-15/16" BR (5/16" Wide Slot)	70-0145
8	Bearing, Take-Up, 1-15/16" BR (11/16" Wide Slot)	70-0161
8A	Bearing, Take-Up, 1-7/16" BR	40-1150
9	Bearing - For 3-1/2" Idler/Take-Up Pulley (1-1/8" SQ BR)	35-0360
	Bearing - For 3-1/2" Idler/Take-Up Pulley (1-1/16" HX BR)	7220706
10	Chain - RC-50	20-0970
	Chain - RC-50 Connector Link	20-0040
	Chain - RC-60 (High-Speed)	20-0987
	Chain - RC-60 Connector Link	20-0986
	Chain - RC-80 (High Speed)	20-0989
	Chain - RC-80 Connector Link	20-0070
	Chain - RC-100 (High Speed)	20-1000
	Chain - RC-100 Connector Link	20-0080
10A	Timing Belt - Pitch / Width / Length	
	8mm / 21mm / 1200mm	7001504
	8mm / 21mm / 1280mm	7001506
	8mm / 36mm / 1200mm	7001512
	8mm / 36mm / 1280mm	7001514
	14mm / 37mm / 1400mm	7001519
11	Cable - Safety / Fill Roller	50-0843
12	Filter Regulator	27-1241
13	Spring - Extension	31-1000



Key No.	Part Description	Part Number			
	C-Face Motor	Baldor		Reliance	
		Motor	Brake Motor	Motor	Brake Motor
15	208-230/460V-3PH-60HZ - Standard Efficiency				
	1/2HP 56C	7155562	7742489	7001600	7001631
	3/4HP 56C	7150592	7150962	7001601	7704084
	1HP 56C	7745139	7716179	7001602	7172635
	1-1/2HP 145C	7778225	7716197	7001603	7001511
	2 HP 145TC	7274611	7325286	7001604	7704091
	3 HP 182TC	7747525	7747295	7001605	7704708
	5 HP 184TC	7747294	7817618	7001606	7001612
	7-1/2 HP 213TC	7329946	7005792	7001607	7001613
	208-230/460V-3PH-60HZ - Premium Efficiency				
	1/2HP 56C	7002040	7002030	7830000	7001621
	3/4HP 56C	7002041	7002031	7001615	7001622
	1HP 56C	7002042	7002032	7888089	7001623
	1-1/2HP 145C	7002043	7002033	7001632	7001625
	2 HP 145TC	7002044	7002034	7001617	7001626
	3 HP 182TC	7002045	7002035	7001633	7001627
	5 HP 184TC	7002046	7002036	7001618	7001628
	7-1/2 HP 213TC	7002047	7002037	7001619	7001629
	575V-3PH-60HZ - Standard Efficiency				
	1/2HP 56C	7717583	-	7002088	-
	3/4HP 56C	7717584	7152666	7002089	7002090
	1HP 56C	7717598	7717586	-	7002091
	1-1/2HP 145C	7331614	-	-	-
	2 HP 145TC	7763322	-	-	-
	3 HP 182TC	7362599	-	-	-
	5 HP 184TC	7866559	-	-	-
	7-1/2 HP 213TC	7005793	-	-	-
	575V-3PH-60HZ - Premium Efficiency				
	1/2HP 56C	7002050	7002060	7001621	7002092
	3/4HP 56C	7002051	7002061	7001622	7002093
	1HP 56C	7002052	7002062	7001623	7002094
	1-1/2HP 145C	7002053	7002063	7001625	7002095
	2 HP 145TC	7002054	7002064	7001626	7002096
	3 HP 182TC	7002055	7002065	7001627	7002097
	5 HP 184TC	7002056	7002066	7001628	7002098
	7-1/2 HP 213TC	7002057	7002067	7001629	7002099

Key No.	Item		Part Number			
	C-Face Reducer					
			Assembly			
			Series 400, 600, 800 RU-LS		Series 400, 600, 800 LU-RS	
			SA2000 - Shown (RH)		SA2000 - OPP (LH)	
			SA2001 - OPP (LH)		SA2001 - Shown (RH)	
	Reducer		Grove	Reliance	Grove	Reliance
Reducer Model	Motor Frame	3	L1	2	K1	
16	<b>5:1 Ratio</b>					
	218	56C	7005800		7005801	-
	218	145TC	7005802	-	7005803	-
	220	56C	7005804	-	7005805	-
	220	145TC	7005806	-	7005141	-
	220	184TC	7005807	-	7005808	-
	224	145TC	7005809	-	7005810	-
	224	182TC	7005035	-	7005811	-
	226	56C	7030646	-	7030645	-
	226	145TC	7030649	-	7030648	-
	226	182TC	7005021	-	7030474	-
	226	184TC	7005021	-	7030474	-
	230	184TC	7005039	-	7005812	-
	232	213TC	7005813	-	7005814	-
	175	56C	-	7005899	-	7005900
	175	145TC	-	7005901	-	7005902
	200	56	-	7005920	-	7005921
	200	145TC	-	7005922	-	7005923
	200	182TC	-	7005924	-	7005925
	262	56C	-	7005940	-	7005941
	262	145TC	-	7005942	-	7005943
	262	182TC	-	7005944	-	7005945
262	184TC	-	7005944	-	7005945	
350	184TC	-	7005968	-	7005969	

Key No.	Item		Part Number			
	C-Face Reducer					
			Assembly			
			Series 400, 600, 800 RU-LS		Series 400, 600, 800 LU-RS	
			SA2000 - Shown (RH)		SA2000 - OPP (LH)	
			SA2001 - OPP (LH)		SA2001 - Shown (RH)	
	Reducer		Grove	Reliance	Grove	Reliance
Reducer Model	Motor Frame	3	L1	2	K1	
16	<b>7.5:1 Ratio</b>					
	220	56C	7005815	-	7005025	-
	220	145TC	7005159	-	7005027	-
	224	145TC	7005816	-	7005036	-
	224	182TC	7005817	-	7005818	-
	230	184TC	7005819	-	7005820	-
	232	213TC	7005821	-	7005822	-
	242	213TC	7005823	-	7005824	-
	200	56C	-	7005926	-	7005927
	200	145TC	-	7005928	-	7005929
	262	182TC	-	7005946	-	7005947
	350	182TC	-	N/A	-	N/A
16	<b>10:1 Ratio</b>					
	218	56C	7005825	-	7005826	-
	220	56C	7005223	-	7005312	-
	220	145TC	7005827	-	7005828	-
	224	145TC	7005830	-	7005831	-
	226	56C	7031010	-	7031017	-
	226	145TC	7030471	-	7030470	-
	230	182TC	7005832	-	7005833	-
	232	182TC	7031008	-	7031009	-
	232	184TC	7031008	-	7031009	-
	242	184TC	7005834	-	7005835	-
	242	213TC	7005836	-	7005837	-
	175	56C	-	7005903	-	7005904
	200	56C	-	7005930	-	7005931
	200	145TC	-	7005932	-	7005933
	262	56C	-	7005948	-	7005949
	262	145TC	-	7005950	-	7005951
350	182TC	-	7005972	-	7005973	

Key No.	Item		Part Number			
	C-Face Reducer					
			Assembly			
			Series 400, 600, 800 RU-LS		Series 400, 600, 800 LU-RS	
			SA2000 - Shown (RH)		SA2000 - OPP (LH)	
			SA2001 - OPP (LH)		SA2001 - Shown (RH)	
	Reducer		Grove	Reliance	Grove	Reliance
Reducer Model	Motor Frame	3	L1	2	K1	
16	<b>15:1 Ratio</b>					
	218	56C	7005838	-	7005839	-
	220	56C	7005221	-	7005840	-
	220	145TC	7005033	-	7005841	-
	224	56C	7005037	-	7005158	-
	224	145TC	7005038	-	7005032	-
	226	56C	7031016	-	7031014	-
	226	145TC	7005086	-	7005030	-
	230	182TC	7005142	-	7005731	-
	232	145TC	7005842	-	7005843	-
	232	182TC	7005092	-	7005091	-
	242	184TC	7005844	-	7005845	-
	242	213TC	7005846	-	7005847	-
	175	56C	-	7005905	-	7005906
	200	56C	-	7005934	-	7005935
	262	56C	-	7005952	-	7005953
	262	145TC	-	7005954	-	7005955
	350	145TC	-	7005974	-	7005975
	350	182TC	-	7005976	-	7005977

Key No.	Item		Part Number			
	C-Face Reducer					
			Assembly			
			Series 400, 600, 800 RU-LS		Series 400, 600, 800 LU-RS	
			SA2000 - Shown (RH)		SA2000 - OPP (LH)	
			SA2001 - OPP (LH)		SA2001 - Shown (RH)	
	Reducer		Grove	Reliance	Grove	Reliance
Reducer Model	Motor Frame	3	L1	2	K1	
16	<b>20:1 Ratio</b>					
	218	56C	7005848	-	7005849	-
	220	56C	7005850	-	7005851	-
	224	56C	7005852	-	7005853	-
	224	145TC	7005854	-	7005333	-
	226	56C	7031012	-	7031013	-
	226	145TC	7005081	-	7005080	-
	230	182TC	7005855	-	7005320	-
	232	145TC	7030647	-	7031018	-
	232	182TC	7005090	-	7005089	-
	242	182TC	7005856	-	7005857	-
	242	184TC	7005856	-	7005857	-
	175	56C	-	7005907	-	7005908
	200	56C	-	7005936	-	7005937
	262	56C	-	7005746	-	7005956
	262	145TC	-	7005957	-	7005958
	350	145TC	-	7005978	-	7005979
350	182TC	-	7005980	-	7005981	

Key No.	Item		Part Number			
	C-Face Reducer					
			Assembly			
			Series 400, 600, 800 RU-LS		Series 400, 600, 800 LU-RS	
			SA2000 - Shown (RH)		SA2000 - OPP (LH)	
			SA2001 - OPP (LH)		SA2001 - Shown (RH)	
Reducer		Grove	Reliance	Grove	Reliance	
Reducer Model	Motor Frame	3	L1	2	K1	
16	<b>25:1 Ratio</b>					
	218	56C	7005858	-	7005859	-
	220	56C	7005860	-	7005861	-
	224	56C	7005862	-	7005863	-
	224	145TC	7005864	-	7005865	-
	226	56C	7031015	-	7031011	-
	230	145TC	7005866	-	7005867	-
	232	145TC	7005085	-	7005084	-
	232	182TC	7005088	-	7005087	-
	175	56C	-	7005909	-	7005910
	200	56C	-	7005744	-	7005913
	262	56C	-	7005754	-	7005742
	262	145TC	-	7005959	-	7005960
	350	145TC	-	7005982	-	7005983
	350	182TC	-	7005984	-	7005985
	<b>30:1 Ratio</b>					
	218	56C	7005868	-	7005869	-
	224	56C	7005870	-	7005783	-
	226	56C	7005069	-	7005068	-
	230	56C	7005871	-	7005872	-
	232	145TC	7005083	-	7005082	-
	242	145TC	7005874	-	7005875	-
	242	182TC	7005766	-	7005876	-
	175	56C		7005911		7005912
	200	56C		7005914		7005915
	262	56C		7005961		7005962
	350	145TC		7005986		7005541

Key No.	Item		Part Number			
	C-Face Reducer					
			Assembly			
			Series 400, 600, 800 RU-LS		Series 400, 600, 800 LU-RS	
			SA2000 - Shown (RH)		SA2000 - OPP (LH)	
			SA2001 - OPP (LH)		SA2001 - Shown (RH)	
	Reducer		Grove	Reliance	Grove	Reliance
Reducer Model	Motor Frame	3	L1	2	K1	
16	<b>40:1 Ratio</b>					
	220	56C	7005877	-	7005878	-
	224	56C	7005879	-	7005328	-
	226	56C	7005065	-	7005064	-
	230	56C	7005880	-	7005881	-
	232	145TC	7005075	-	7005074	-
	242	145TC	7005882	-	7005883	-
	242	182TC	7005321	-	7005884	-
	200	56C	-	7005916	-	7005917
	262	56C	-	7005752	-	7005963
	350	145TC	-	7005987	-	7005988
16	<b>50:1 Ratio</b>					
	224	56C	7005885	-	7005886	-
	232	56C	7005887	-	7005888	-
	232	145TC	7005073	-	7005072	-
	242	145TC	7005889	-	7005890	-
	200	56C	-	7005918	-	7005919
	262	56C	-	7005964	-	7005965
	350	56C	-	7005989	-	7005990
350	145TC	-	7005991	-	7005992	

Key No.	Item		Part Number			
	C-Face Reducer					
			Assembly			
			Series 400, 600, 800 RU-LS		Series 400, 600, 800 LU-RS	
			SA2000 - Shown (RH)		SA2000 - OPP (LH)	
			SA2001 - OPP (LH)		SA2001 - Shown (RH)	
	Reducer		Grove	Reliance	Grove	Reliance
Reducer Model	Motor Frame	3	L1	2	K1	
16	<b>60:1 Ratio</b>					
	220	56C	7005891	-	7005892	-
	224	56C	7005893	-	7005894	-
	226	56C	7005061	-	7005060	-
	230	56C	7005895	-	7005896	-
	232	56C	7005067	-	7005066	-
	232	145TC	7005071	-	7005070	-
	242	145TC	7005897	-	7005898	-
	200	56C	-	7005938	-	7005939
	262	56C	-	7005966	-	7005967
	350	56C	-	7005993	-	7005994
	350	145TC	-	7005995	-	7005996



Key No.	Item		Part Number					
	Chain Sprocket (Power Unit - Driver)							
	Size - Teeth - Belt Width	Sprocket Hub Type (TL Bushing No.)	Reducer Output Shaft Diameter					
.875			1.000	1.125	1.250	1.500	1.875	
17	Series 400 / 600 / 800 - End Drive							
	RC50 - 11T	Type B Hub	745505					
	RC50 - 13T	Type B Hub	745513	745512	745510			
	RC50 - 14T	Type B Hub			745514			
	RC50 - 17T	Type B Hub			745517			
	RC60 - 9T	Type B Hub	745100					
	RC60 - 10T	Type B Hub	745101		745102			
	RC60 - 11T (TL Bushing)	Type B Hub	745111	745110	745112			
		Type TL Hub (1008)	745631		745631			
			230701					
	RC60 - 13T (TL Bushing)	Type B Hub			745133			
		Type TL Hub (1210)	745633	745633	745633			
			230716	230717	230718			
	RC60 - 14T (TL Bushing)	Type B Hub			745142		745144	
		Type TL Hub (1210)	745634	745634	745634		745634	
			230716	230717	230718			
	RC60 - 15T (TL Bushing)	Type TL Hub (1610)	745635	745635	745635		745635	
			230746	230747	230748		230753	
	RC60 - 16T (TL Bushing)	Type B Hub					745165	
		Type TL Hub (1610)					745636	
							230753	
RC60 - 17T (TL Bushing)	Type B Hub					745176		
	Type TL Hub (1610)			745637		745637		
				230748		230753		
RC60 - 18T (TL Bushing)	Type TL Hub (1610)	745638	745638	745638		745638		
		230746	230747	230748		230753		
RC60 - 19T (TL Bushing)	Type TL Hub (1610)	745639	745639	745639		745639		
		230746	230747	230748		230753		
RC60 - 20T (TL Bushing)	Type TL Hub (2012)					745640		
						230785		
RC60 - 21T (TL Bushing)	Type TL Hub (2012)					745641		
						230785		

Key No.	Item		Part Number					
	Chain Sprocket (Power Unit - Driver)							
	Size - Teeth - Belt Width	Sprocket Hub Type (TL Bushing No.)	Reducer Output Shaft Diameter					
.875			1.000	1.125	1.250	1.500	1.875	
17	RC60 - 22T (TL Bushing)	Type TL Hub (2012)		745642	745642		745642	
				230777	230778		230785	
	RC60 - 25T (TL Bushing)	Type TL Hub (1008)????					745645	
	RC60 - 26T (TL Bushing)	Type TL Hub (1210)					745646	
	RC60 - 29T (TL Bushing)	Type TL Hub (1610)					745649	
							230753	
	RC60 - 30T (TL Bushing)	Type TL Hub (1610)					745650	
							230753	
	RC80 - 11T	Type B Hub					745313	
	RC80 - 12T	Type B Hub					745322	
	(TL Bushing)	Type TL Hub (1615)					745683	
							230766	
	RC80 - 13T	Type B Hub					745333	
	(TL Bushing)	Type TL Hub (1615)					745684	
							230766	
	RC80 - 14T	Type B Hub					745342	
	(TL Bushing)	Type TL Hub (1615)					745685	
							230766	
	RC80 - 16T	Type B Hub					745360	
	(TL Bushing)	Type TL Hub (2012)						745687
							230786	
RC80 - 17T	Type B Hub						745372	
(TL Bushing)	Type TL Hub (2012)						745688	
							230786	
RC80 - 18T	Type TL Hub						745689	
(TL Bushing)	(2012)						230786	
RC80 - 19T	Type TL Hub						745690	
(TL Bushing)	(2012)						230786	
RC80 - 20T	Type TL Hub						745691	
(TL Bushing)	(2517)						230798	
RC80 - 21T	Type TL Hub						745692	
(TL Bushing)	(2517)						230798	
RC80 - 23T	Type TL Hub						745694	
(TL Bushing)	(2517)						230798	

Key No.	Item		Part Number						
	Chain Sprocket (Power Unit - Driver)								
	Size - Teeth - Belt Width	Sprocket Hub Type (TL Bushing No.)	Reducer Output Shaft Diameter						
.875			1.000	1.125	1.250	1.500	1.875		
17	RC100 - 10T	Type B Hub						745500	
	RC100 - 11T	Type B Hub						745432	
		Type TL Hub						745718	
		(SDS)						230759	
	RC100 - 12T	Type B Hub						745440	
		Type TL Hub						745719	
		(SDS)						230759	
	RC100 - 13T	Type TL Hub						745723	
		(2012)						230786	
	RC100 - 14T	Type TL Hub						745758	
		(2517)						230798	
	SA2000 / 2001 - Intermediate / Low-Profile Drive								
	RC60 - 16T (TL Bushing)	Type TL Hub (1610)		7788120	7788120	7788120	7788120		
				7115210	7115213	7115223	7115228		
	RC60 - 19T (TL Bushing)	Type TL Hub (1610)		7742721	7742721	7742721	7742721		
				7115210	7115213	7115223	7115228		
	RC60 - 20T (TL Bushing)	Type TL Hub (2012)		7743918	7743918	7743918	7743918		
				7115235	7115228	7115227	7721059		
	RC60 - 21T (TL Bushing)	Type TL Hub (2012)		7120512	7120512	7120512	7120512	7120512	
				7115235	7115228	7115227	7721059	7115234	
RC60 - 22T (TL Bushing)	Type TL Hub (2012)		7000092	7000092	7000092	7000092			
			7115235	7115228	7115227	7721059			
RC60 - 23T (TL Bushing)	Type TL Hub (2012)		7125294	7125294	7125294	7125294			
			7115235	7115228	7115227	7721059			
RC60 - 25T (TL Bushing)	Type TL Hub (2012)		7730801	7730801	7730801	7730801	7730801		
			7115235	7115228	7115227	7721059	7115234		

Key No.	Item		Part Number					
	Chain Sprocket (Power Unit - Driver)							
	Size - Teeth - Belt Width	Sprocket Hub Type (TL Bushing No.)	Reducer Output Shaft Diameter					
.875			1.000	1.125	1.250	1.500	1.875	
17A	Timing-Belt Sprocket (Power Unit - Driver)							
	8mm-30T-21 (TL Bushing)	Type TL Hub (1108)		7001533				
				7001513				
	8mm-32T-21 (TL Bushing)	Type TL Hub (1210)		7001534	7001534			
				7200560	7115208			
	8mm-32T-36 (TL Bushing)	Type TL Hub (1210)				7001551		
						7115207		
	8mm-34T-21 (TL Bushing)	Type TL Hub (1610)		7001535	7001535	7001535		
				7115210	7115213	7115223		
	8mm-34T-36 (TL Bushing)	Type TL Hub (1210)				7001552		
						7115207		
	8mm-36T-21 (TL Bushing)	Type TL Hub (1610)		7001536	7001536			
				7115210	7115213			
	8mm-36T-36 (TL Bushing)	Type TL Hub (1610)			7001553			
					7115213			
	8mm-38T-21 (TL Bushing)	Type TL Hub (1610)		7001537	7001537	7001537		
				7115210	7115213	7115223		
	8mm-38T-36 (TL Bushing)	Type TL Hub (1610)			7001554	7001554	7001554	
					7115213	7115223	7732428	
	8mm-40T-21 (TL Bushing)	Type TL Hub (2012)		7001538	7001538	7001538		
				7115235	7115228	7115227		
	8mm-40T-36 (TL Bushing)	Type TL Hub (2012)				7001555		7001555
						7115227		7115234
	8mm-42T-21 (TL Bushing)	Type TL Hub (2012)		7001539	7001539	7001539		
				7115235	7115228	7115227		
	8mm-42T-36 (TL Bushing)	Type TL Hub (2012)			7001556			
					7115228			
	8mm-45T-21 (TL Bushing)	Type TL Hub (2012)		7001540	7001540	7001540		
			7115235	7115228	7115227			
8mm-48T-21 (TL Bushing)	Type TL Hub (2012)		7001541	7001541	7001541			
			7115235	7115228	7115227			
8mm-48T-36 (TL Bushing)	Type TL Hub (2012)				7001558			
					7115227			
8mm-50T-21 (TL Bushing)	Type TL Hub (2012)		7001542	7001542	7001542			
			7115235	7115228	7115227			

Key No.	Item		Part Number					
	Chain Sprocket (Power Unit - Driver)							
	Size - Teeth - Belt Width	Sprocket Hub Type (TL Bushing No.)	Reducer Output Shaft Diameter					
.875			1.000	1.125	1.250	1.500	1.875	
17A	14mm-28T-37 (TL Bushing)	Type TL Hub (2012)					7001566	7001566
							7721059	7115234
	14mm-30T-37 (TL Bushing)	Type TL Hub (2517)				7001568	7001568	7001568
						7001524	7756668	7174980
	14mm-32T-37 (TL Bushing)	Type TL Hub (2517)					7001570	7001570
							7756668	7174980
	14mm-34T-37 (TL Bushing)	Type TL Hub (2517)					7001572	7001572
							7756668	7174980
	14mm-36T-37 (TL Bushing)	Type TL Hub (2517)					7001574	7001574
							7756668	7174980
	14mm-40T-37 (TL Bushing)	Type TL Hub (3020)				7001578		
						7001527		

Key No.	Item	Part Number			
18	Chain Sprocket (Pulley Driven)				
	Size - Teeth - Belt Width	Sprocket Hub Type (TL Bushing No.)	Reducer Output Shaft Diameter		
			1.187"	1.427"	1.675"
	Series 400, 600, and 800 - End Drive				
	RC50 - 13T	Type B Hub	745511		
	RC60 - 21T	Type B Hub		745207	
	(TL Bushing)	Type TL Hub (2012)		745641	
				230781	
	RC60 - 27T	Type B Hub			745270
	(TL Bushing)	Type TL Hub (2012)			745647
					230782
	RC80 - 15T	Type B Hub		745350	
	(TL Bushing)	Type TL Hub (1615)		745686	
				230769	
	RC80 - 19T	Type B Hub			745392
	(TL Bushing)	Type TL Hub (2012)			745690
					230782
	RC100 - 15T	Type TL Hub			745725
	(TL Bushing)	(2517)			230793
	SA2000 / 2001 - Intermediate / Low Profile				
RC60 - 26T	Type TL Hub			7717361	
(TL Bushing)	(2012)			7115238	
RC60 - 32T	Type TL Hub			7742328	
(TL Bushing)	(2012)			7115238	

Key No.	Item	Part Number			
18A	Timing-Belt Sprocket (Pulley - Driven)				
	8mm-71T-21 (TL Bushing)	Type TL Hub (2517)			7001548
					7115239
	8mm-71T-36 (TL Bushing)	Type TL Hub (2517)			7001563
					7115239
	8mm-75T-21 (TL Bushing)	Type TL Hub (2517)			7001549
					7115239
	8mm-75T-36 (TL Bushing)	Type TL Hub (2517)			7001564
					7115239
	8mm-80T-21 (TL Bushing)	Type TL Hub (2517)			7001550
					7115239
	8mm-80T-36 (TL Bushing)	Type TL Hub (3020)			7001565
				7000084	
14mm-50T-37 (TL Bushing)	Type TL Hub (3020)			7001582	
				7000084	
14mm-53T-37 (TL Bushing)	Type TL Hub (3020)			7001583	
				7000084	
14mm-56T-37 (TL Bushing)	Type TL Hub (3525)			7001584	
				7000085	
19	Chain Sprocket (Power Feeder, Jackknife Pulley - Driver / Driven)				
	RC50 - 15T (H Bushing)	Type H Hub		745551	
				239510	
	RC50 - 17T (TL Bushing)	Type TL Hub (1610)		1225017	
				230950	
	RC50 - 19T (TL Bushing)	Type TL Hub (1610)		1225019	
				230950	
	RC50 - 21T (TL Bushing)	Type TL Hub (1610)		1225021	
			230950		
RC50 - 23T (TL Bushing)	Type TL Hub (2012)		1225023		
			230981		
Note: "B" = Sprocket with finished bore. "TL" = Sprocket with taper-bore bushing. "H" = Sprocket with split taper bushing.					

## Width Related Parts

Key No.	Part Description	Part Number				
		16"	22"	28"	34"	40"
		Note: Belt Width = Conveyor Width MINUS 4".				
21	Belt - Horizontal Conveyor (Specify Footage Required)					
	PVC 100 Brushed x FS (Black)	19-0355	19-0491	19-0550	19-0582	19-0595
22	Belt - Incline/Decline Conveyor (Specify Footage Required)					
	PVC 100 RT x FS (Black)	19-0360	19-0492	19-0580	19-0583	19-0594
23	Belt - Inclined Power Feeder - FS x FS (Cut to Length; No Lacing/Pin)					
	3'-0" Ig. Power Feeder (91" lg.)	19-0266	19-0272			
	4'-0" Ig. Power Feeder (116" lg.)	19-0185	19-0192	19-0198		
	7'-0" Ig. Power Feeder (188" lg.)				19-0204	19-0210
24	Belt - Inclined Power Feeder - RT x FS (Cut to Length; No Lacing/Pin)					
	3'-0" Ig. Power Feeder (91" lg.)	19-0267	19-0273			
	4'-0" Ig. Power Feeder (116" lg.)	19-0186	19-0193	19-0199		
	7'-0" Ig. Power Feeder (188" lg.)				19-0205	19-0211
25	Belt - Declined Power Feeder - FS x FS (Cut to Length; No Lacing/Pin)					
	3'-0" Ig. Power Feeder (104" lg.)	19-0373	19-0375			
	4'-0" Ig. Power Feeder (131" lg.)	19-0377	19-0379	19-0381		
	7'-0" Ig. Power Feeder (203" lg.)				19-0383	19-0385
26	Belt - Decline Power Feeder - RT x FS (Cut to Length; No Lacing/Pin)					
	3'-0" Ig. Power Feeder (104" lg.)	19-0374	19-0376			
	4'-0" Ig. Power Feeder (131" lg.)	19-0378	19-0380	19-0382		
	7'-0" Ig. Power Feeder (203" lg.)				19-0384	19-0386
27	Belt - Reversible Power Feeder - FS x FS (Cut to Length; No Lacing/Pin)					
	4'-0" Ig. Power Feeder (124" lg.)	19-0235	19-0242	19-0248		
	7'-0" Ig. Power Feeder (196" lg.)				19-0254	19-0260
28	Belt - Reversible Power Feeder - RT x FS (Cut to Length; No Lacing/Pin)					
	4'-0" Ig. Power Feeder (124" lg.)	19-0236	19-0243	19-0249		
	7'-0" Ig. Power Feeder (196" lg.)				19-0255	19-0261



Key No.	Part Description	Part Number				
		16"	22"	28"	34"	40"
32	Belt Lacing - Clipper (Quantity Required)					
	No. 1A, 6" lg. (FS x FS)	19-0701(4)	19-0701(6)	19-0701(8)	19-0701(10)	19-0701(12)
	No. 1, 6" lg. (RT x FS)	19-0702(4)	19-0702(6)	19-0702(8)	19-0702(10)	19-0702(12)
	Belt Lacing Pin - Clipper					
	No. 25 (for No. 1/1A Lacing)	19-0709(1)	19-0709(1.5)	19-0709(2)	19-0709(2.5)	19-0709(3)
33	Belt Lacing with Pin - Alligator					
	No. 7 (FS x FS)	19-0880	19-0892	19-0894	19-0896	19-0898
	No. 15 (RT x FS)	19-0966	19-0968	19-0970	19-0980	19-0990
34	Pulley/Shaft, Drive, Crown Face, Lagged, Single Shaft Extension (Power Unit)					
	Series 400 - 4-3/16" x 1-3/16"	48-53016	48-53022	48-53028	58-53034	48-53040
	Series 600 - 6-3/16" x 1-7/16"	48-52416	48-52422	48-52428	48-52434	48-52440
	Series 800 - 8-3/16" x 1-11/16"	48-52716	48-52722	48-52728	48-52734	48-52740
34A	Pulley w/Shaft, Drive, Crown Face, Lagged (SA2000 Intermediate Drive)					
	8-1/4" dia., 1-11/16" Shaft	7005177	7005179	7005008	7005181	7005183
34B	Pulley w/Shaft, Drive, Crown Face, Lagged (SA2001 Low Profile Intermediate Drive)					
	6-1/4" dia., 1-11/16" Shaft	7005289	7005291	7005004	7005293	7005295
35	Pulley/Shaft, Drive, Crown-Face, Lagged, Double Shaft Extension (Power Unit w/PTO)					
	Series 600 - 6-3/16" x 1-7/16"	48-52516	48-58522	48-52528	48-52534	48-52450
	Series 800 - 8-3/16" x 1-11/16"	48-52316	48-52322	48-52328	48-52334	48-52340
37	Pulley/Shaft, Idler, Crown-Face, Lagged, Single Shaft Extension (Idler w/PTO)					
	6" x 1-15/16" (Stepped to 1-7/16")	68-1468	68-1469	68-1470	68-1472	68-1473
38	Pulley/Axle, Idler, Crown-Face (End Idler)					
	3-1/2" x 1-1/8" SQ BR	50-1243	50-1244	50-1245	50-1246	50-1250
	Axle - 1-1/8" SQ (End Idler Assy.)	69-0909	69-0910	69-0919	69-0920	69-0970
39	Pulley/Axle, Take-Up, Crown-Face (Series 600/800) End Dr - Jackknife/Power Feeder					
	3-1/2" x 1-1/8" SQ BR	50-1243	50-1244	50-1245	50-1246	50-1250
	Axle - 1-1/8" SQ CRS	69-0942	69-0943	69-0944	69-0945	69-0946
40	Pulley/Axle, Idler, Flat Face, (Series 600/800) End Dr - Jackknife/Power Feeder					
	3-1/2" x 1-1/8" SQ BR	50-1238	50-1239	50-1240	50-1241	50-1247
	Axle - 1-1/8" SQ CRS	69-0942	69-0943	69-0944	69-0945	69-0946
40A	Pulley & Axle, Take-Up, Crown Face, (SA2000 / 2001 Intermediate / Low Profile)					
	3-1/2" x 1-1/16" HX BR	7005184	7005188	7005009	7005186	7005187
	Axle - 1-1/16" CRS Hex	7005188	7005189	7005010	7005190	7005191

Key No.	Part Description	Part Number				
		16"	22"	28"	34"	40"
42	Pulley/Shaft, Take-Up - Crown Faced, No Shaft Extension - Auxiliary TU					
	6" x 1-15/16"	48-52616	48-52622	48-52628	48-52634	48-52640
42A	Pulley/Shaft, Take-Up - Crown Faced, No Shaft Extension - Auxiliary Spring TU					
	5.5" x 1-7/16"	68-5036	68-5037	68-5038	68-5039	68-5040
43	Pulley/Shaft, Idler - Flat Faced, No Shaft Extension - Auxiliary TU					
	6" x 1-7/16"	48-52916	48-52922	48-52928	48-52934	48-52940
43A	Pulley/Shaft, Idler - Flat Faced, No Shaft Extension - Auxiliary Spring TU					
	5.5" x 1-5/16"	68-5026	68-5027	68-5028	68-5029	68-5030
44	Pulley - Idler Knife Edge					
	2-1/4" x 3/4" BR	51-0001	51-0002	51-0003	51-0004	51-0005
45	Pulley/Shaft, Driven (DN) Power Feeder, Crown-Face, Lagged, Single Shaft Ext.					
	Incl./Decl/Rev PF 6-3/16" x 1-7/16"	68-3251	68-3252	68-3253	68-3254	68-3255
46	Pulley/Shaft, Driver (DR) - Power Feeder, Crown-Face, Lagged, Single Shaft Ext.					
	Inclined PF 6-3/16" x 1-7/16"	68-3251	68-3252	68-3253	68-3254	68-3255
	Decl/Rev PF 6-3/16" x 1-15/16"	68-3256	68-3257	68-3258	68-3259	68-3260
47	Pulley/Shaft, Driver (DR) - Powered Jackknife, Crown-Face, Double Shaft Ext.					
	Incline JK 6-3/16" x 1-7/16"	4852516	4852522	4852528	4852534	4852540
48	Pulley/Shaft, Driven (DN) - Powered Jackknife, Crown-Face, Lagged, Single Shaft Ext.					
	Incline JK 6-3/16" x 1-7/16"	4852416	4852422	4852428	4852434	4852440
49	Pulley/Shaft Driver (DR) - Non-Powered Jackknife, Crown-Face, Lagged, Single Shaft Ext.					
	Decline JK 6-3/16" x 1-15/16"	68-1468	68-1469	68-1470	68-1472	68-1473
50	Pulley/Shaft Drive (DN) - Non-Powered Jackknife, Crown-Face, Lagged, Single Ext. Shaft					
	Decline JK 6-3/16" x 1-7/16"	4852416	4852422	4852428	4852434	4852440

Key No.	Part Description	Conveyor Width "W" Part Number				
		16"	22"	28"	34"	40"
51*	Roller/Shaft - Carrier/Belt Return (Roller BED - BCR, and Slide Bed - BCS)					
	RLR G196 GH P 01 __-__ NC	7017540	7017541	7017542	7017543	7017544
	RLR G196 A1 P 01 __-__ NC	7015687	7015688	7015689	7015690	7015691
51A*	Roller/Shaft - Belt Return (Box-Bed - BCB)					
	RLR G196 GH P 01 15.81 NC	7496328	-	-	-	-
	RLR G196 GH P 01 21.81 NC	-	7496429	-	-	-
	RLR G196 GH P 01 27.81 NC	-	-	7496521	-	-
	RLR G196 GH P 01 33.81 NC	-	-	-	7496600	-
	RLR G196 GH P 01 39.81 NC	-	-	-	-	7496655
	RLR G196 A1 P 01 15.81 NC	7491816	-	-	-	-
	RLR G196 A1 P 01 21.81 NC	-	7491817	-	-	-
	RLR G196 A1 P 01 27.81 NC	-	-	7491818	-	-
	RLR G196 A1 P 01 33.81 NC	-	-	-	7491819	-
RLR G196 A1 P 01 39.81 NC	-	-	-	-	7491820	
52	Roller and Axle - Fill					
	No. G131P (1-5/16" x 3/8" HX BR)	501095	501096	501097	501098	501099
53	Roller/Shaft - Snub/Take-Up					
	No. G251AB 2-1/2" x 11/16" HX BR	501056	501057	501058	501059	501060
54	Roller - Adjustable / Fixed Snub SA2000 and SA2001					
	2-9/16" x 11/16 HX BR	7005192	7005193	7005011	7005194	7005195
54A	Shaft - Adjustable Snub SA2001					
	11/16' CRS Hex	7005196	7005197	7005012	7005198	7005199
54B	Shaft - Fixed Snub SA2001					
	11/16' CRS Hex	7005296	7005297	7005045	7005298	7005299

(\*) Roller Description Explanation

(Example) RLR G 196 GH P 01 16.00 NC

NC = No Cover  
 16.00 = Conveyor Width "W"  
 01 = Spring-Loaded Axle; Fixed Roller w/o Grooves  
 P = Plain Steel Axle  
 A1 = (Bearing Type) ABEC Precision Bearing  
 GH = (Bearing Type) Greased, Commercial Bearing  
 196 = (Roller Tube) 1.90" dia x 16 gage (.065" wall)  
 G = (Roller Tube Material/Finish) Galvanized Steel  
 RLR = Roller

---

## Lubricants and Paints

Part Description	Part Number
Reducer Lubricant	
Groove / Reliance Reducer, +20° F (1) Gallon	Consult Factory
Grove / Reliance Reducer, -20° to +20° F (1) Gallon	Consult Factory
Paint	
FKI Logistex Satin Gray - Spray Can	7900005