

# **Product Manual** **Powered Belt Conveyor**

Application Guidelines, Specifications, Installation  
Procedures, Maintenance, Parts Identification,  
and Product Index



To contact Intelligrated:

For service: Customer Service and Support (CSS)

Hotline 1-877-315-3400

On the World Wide Web: [www.intelligrated.com](http://www.intelligrated.com)

By mail:

Intelligrated  
7901 Innovation Way  
Mason, OH 45040

(513) 701-7300

Read these documents thoroughly before attempting to perform maintenance or repairs to the applicable Intelligrated conveyor system components or devices. Exercise extreme caution when working around moving and rotating conveyor equipment. Wear the proper clothing and safety equipment. **DO NOT** attempt to perform any maintenance until the equipment is de-energized, locked out and tagged out in accordance with established company procedures.

The information presented in these documents are correct at the time of publication. Intelligrated has made every effort to ensure that the information presented is correct and free from error. However, some errors or misprints may occur. Please contact Intelligrated with any corrections.

This document is copyrighted © 2010 by Intelligrated, all rights reserved. No Part of this manual may be reproduced and/or distributed to parties other than the customer and the customer's employees for whom it was originally produced.

The following terms are trademarks™ of Intelligrated; Accuglide™, BOSS™ UniSort™, EZ-set™. The following terms are registered trademarks® of Intelligrated; Accuzone®, UniSort®, E-Z Set®. Intelligrated® is a registered trademark.

Direct questions and comments concerning the information contained in this manual to:

Documentation Department  
Intelligrated  
7901 Innovation Way  
Mason, OH 45040

Ph (513) 701-7300

Fax (513)701-7349

[customerservice@intelligrated.com](mailto:customerservice@intelligrated.com)



# Package Conveyors



 <p><b>Do Not Climb, Sit, Stand, Walk, Ride, or Touch the Conveyor at Any Time</b></p>	 <p><b>Do Not Perform Maintenance on Conveyor Until Electrical, Air, Hydraulic and Gravity Energy Sources Have Been Locked Out or Blocked</b></p>	 <p><b>Operate Equipment Only With All Approved Covers and Guards in Place</b></p>
 <p><b>Do Not Load a Stopped Conveyor or Overload a Running Conveyor</b></p>	 <p><b>Ensure That All Personnel Are Clear of Equipment Before Starting</b></p>	 <p><b>Allow Only Authorized Personnel To Operate or Maintain Material Handling Equipment</b></p>
 <p><b>Do Not Modify or Misuse Conveyor Controls</b></p>	 <p><b>Keep Clothing, BodyParts, and Hair Away from Conveyors</b></p>	 <p><b>Remove Trash, Paperwork, and Other Debris Only When Power is Locked Out and Tagged Out</b></p>
 <p><b>Ensure That ALL Controls and Pull Cords are Visible and Accessible</b></p>	 <p><b>Know the Location and Function of All Stop and Start Controls</b></p>	 <p><b>Report All Unsafe Conditions Jams should be cleared ONLY BY Authorized, Trained, Personnel</b></p>

POST IN PROMINENT AREA



---

## Product Manual Issue and Revision Date(s)

1st Issue	April 2001
Previous Revision	December 2006
Current Revision	September 2007

## Product Manual Revision Summary

<b>Revision Date</b>	<b>Manual Section(s)</b>	<b>Revision Summary</b>
December 2006	Section I	Updated Carrier Roller Part Numbers
September 2007	All	Footer Correction - Issue Date



**Section A Product Summary**

Powered Belt Conveyor - Product Summary ----- A - 1

    Overview ----- A - 1

    CSPS Designation ----- A - 1

    Applications ----- A - 1

    Widths ----- A - 1

        Belt Widths ----- A - 1

        Between Frame (BF) Dimension "W" ----- A - 1

    Intermediate/Idler Sections ----- A - 1

    Carrier and Belt Return Rollers ----- A - 1

    Intermediate Drives ----- A - 2

    End Drives ----- A - 2

    Power Units ----- A - 2

    Power Feeders ----- A - 2

    Jackknives ----- A - 2

    Upper Bends ----- A - 3

    Auxiliary Take-Ups ----- A - 3

    Accessories ----- A - 3

    Finish ----- A - 3

**Section B Application Guidelines**

Introduction ----- B - 1

    Product Line ----- B - 1

    Functional Capabilities ----- B - 1

    Conveyability ----- B - 1

    Environmental Considerations ----- B - 1

Product Description ----- B - 2

    Conveyor Side Rails ----- B - 2

        Channel Frame (CF) ----- B - 2

        Pick Belt (PK) ----- B - 2

        Swivel Roller (SR) ----- B - 2

    Bed Types ----- B - 3

        Slider Bed ----- B - 3

        Roller Bed ----- B - 4

    Equipment Components ----- B - 5

        Intermediate Sections ----- B - 5

        End Idler Sections ----- B - 5

        End Drives ----- B - 6

        Intermediate Drives ----- B - 7

        Driven Jackknife Sections ----- B - 9

        Power Units ----- B - 9

        PTO Connections ----- B - 9

        Power Feeder Units ----- B - 10

        Non-Driven Jackknife Sections ----- B - 10

        Auxiliary Take-Ups ----- B - 10

        Upper Bend Units ----- B - 11

---

Applications .....	B - 12
Styles .....	B - 12
Transportation .....	B - 13
Horizontal .....	B - 13
Incline/Decline Units .....	B - 13
Accessories .....	B - 13
Design Criteria .....	B - 14
Braking .....	B - 16

**Section C Standard Specifications**

Frame Assemblies .....	C - 1
Frame Rails .....	C - 1
Channel Frame (CF) Type .....	C - 1
Pick Belt (PK) Type .....	C - 1
Swivel Roller (SR) Type .....	C - 1
Beds .....	C - 2
Slider Type .....	C - 2
Roller Type .....	C - 2
Box Bed Type .....	C - 2
Intermediate Section .....	C - 3
Widths “W” (BF) .....	C - 3
Lengths .....	C - 3
Beds .....	C - 3
Belt Return Rollers .....	C - 3
Carrier and Belt Return Rollers .....	C - 3
End Idler Section - BCR and BCS .....	C - 4
Frame .....	C - 4
Bed .....	C - 4
Lengths .....	C - 4
Idler Pulley .....	C - 4
Knife-Edge .....	C - 4
Snub Roller .....	C - 4
Fill Roller (Optional) .....	C - 4
Intermediate Drives .....	C - 5
Frame .....	C - 7
Drive Pulley and Shaft .....	C - 7
Bearings .....	C - 7
Snub Roller .....	C - 7
Take-Up Roller and Shaft .....	C - 7
Capacity .....	C - 7
Mounting .....	C - 7
Safety Guarding .....	C - 7
Width “W” (BF) .....	C - 7
Belt Width .....	C - 7
General Information .....	C - 8



---

End Drives	C - 9
End Drives with Take-Up	C - 9
Drive Frame	C - 9
Drive Pulley and Shaft	C - 9
Pulley/Shaft Diameters	C - 10
Idler/Take-Up Pulley/Shaft	C - 10
Snub Rollers	C - 10
Fill Roller	C - 10
End Drive with Driven Jackknife	C - 10
Power Units	C - 11
Motor	C - 11
Reducer	C - 11
Speeds	C - 11
Chain Drive	C - 11
Chain Sprockets	C - 11
Timing Belt Drive	C - 11
Timing Belt Sprockets	C - 11
Power Unit Mounting	C - 11
PTO Connection	C - 12
End Idler	C - 12
End Drive	C - 12
Transfer Drive Kit - Direct Rotation	C - 12
Transfer Drive Kit - Counter-rotation	C - 12
Speed Ratios	C - 12
Power Feeder Unit	C - 13
Types	C - 13
Frame/Bed	C - 13
Length	C - 13
Belt and Lacing	C - 13
Drive Pulleys	C - 13
Take-Up Pulleys	C - 13
End Idler Pulley	C - 13
Snub Rollers	C - 14
Fill Angle	C - 14
Fill Roller(s)	C - 14
Speed Ratios	C - 14
Non-Driven Jackknife Section	C - 16
Auxiliary Take-Up Sections	C - 17
Manual - Auxiliary Take-Up	C - 17
Frame	C - 17
Idler/Take-Up Pulley/shaft	C - 17
Snub Rollers	C - 17
Spring - Auxiliary Take-Up	C - 17
Frame	C - 17
Idler/Take-Up Pulley/Shaft	C - 17
Snub Rollers	C - 17
Take-Up	C - 17

---

Upper Bend Unit - - - - - C - 18  
     Frame - - - - - C - 18  
     Carrier Rollers - - - - - C - 18  
     Snub Rollers - - - - - C - 18  
 Belts and Lacings - - - - - C - 19  
 Safety Guards - - - - - C - 19  
     Sheet Metal Guards - - - - - C - 19

**Section D Engineering Data**

Determining the Maximum Angle of Incline - - - - - D - 1  
     L/H Ratio - - - - - D - 1  
     Weight Distribution - - - - - D - 2  
     Traction - - - - - D - 2  
 Determining the Conveyor Length - - - - - D - 3  
 Calculating Live Load - - - - - D - 5  
 Determining the Effective Belt Pull - - - - - D - 6  
     Horizontal Conveyors - - - - - D - 6  
     Ascending Conveyors - - - - - D - 8  
     Descending Conveyors - - - - - D - 10  
     Additional Effective Pull for PTO - - - - - D - 13  
     Select the Drive Series - - - - - D - 13  
 Determining the Horsepower - - - - - D - 14  
     Special Start-Up Condition - - - - - D - 14  
 Determining Power Feeder Speed (fpm) - - - - - D - 20  
 Effective Belt Pull Formula - - - - - D - 21  
     Roller Bed - - - - - D - 21  
     Slider Bed - - - - - D - 21  
     Symbols - - - - - D - 22

**Section E Layout Dimensions**

Intermediate Sections - - - - - E - 1  
 End Drive - - - - - E - 2  
 End Idler - - - - - E - 2  
 Intermediate Drives - - - - - E - 3  
 Auxiliary Take-Up Section - - - - - E - 5  
 Upper Bend Section - - - - - E - 6  
 Power Units - - - - - E - 6  
 Driven Jackknife - - - - - E - 7  
 Non-Driven Jackknife - - - - - E - 8  
 Power Feeders - - - - - E - 9

**Section F Accessories**

Powered Belt Conveyor Accessories ----- F - 1

**Section G Installation Procedures**

Accepting Shipment ----- G - 1

    Shortages or Errors ----- G - 1

    Lost or Damaged Shipment ----- G - 1

    Claims and Returns ----- G - 1

Codes and Standards ----- G - 1

Warning Signs ----- G - 2

Safety Precautions ----- G - 2

Parts Replacement ----- G - 2

Factory Assistance ----- G - 2

Pre-Installation Set-up ----- G - 2

Style Identification ----- G - 3

Assembling the Bed Section ----- G - 7

Power Unit Assembly ----- G - 10

    Lubricant ----- G - 10

    Reducer Plugs/Fittings ----- G - 10

    Sprocket Alignment ----- G - 10

    Set Screw Tightening Procedure (Type B Sprockets) ----- G - 10

Installing the Upper Bend Unit ----- G - 11

Installing the Power Feeder and/or Jackknife Unit ----- G - 12

Connector Channel Assemblies ----- G - 13

Installing the Belt ----- G - 14

    Cutting the Belt Ends ----- G - 15

    Splicing the Belt ----- G - 15

    Replacing the Belt(s) ----- G - 16

Installing Electrical Wiring ----- G - 17

Pre-Start-Up Preparation ----- G - 17

    Pre-Operation Check List ----- G - 17

Belt Tracking ----- G - 18

    Principles of Belt Tracking ----- G - 18

    Belt Tracking Instructions ----- G - 18

    Examples of Belt Tracking ----- G - 18

    Belt Tracking Check List ----- G - 22

Adjusting Belt Tension ----- G - 23

Adjusting Snub Rollers ----- G - 24

---

**Section H Maintenance**

General	H - 1
Maintenance Safety	H - 1
New Installations	H - 1
Maintenance Logs	H - 1
Initial Start-up and Run-in Period	H - 1
Chain and Sprockets	H - 1
Power Unit Reducer	H - 2
Scheduled Inspections and Maintenance	H - 2
Daily Inspections	H - 3
Weekly Inspections	H - 3
Belting	H - 3
Belt Lacing	H - 3
Carrier and Belt Return Rollers	H - 3
General Structure and Operation	H - 3
Power Unit Reducer	H - 3
Safety Guards and Devices	H - 3
Electrical Devices	H - 3
Monthly Maintenance	H - 4
External Bearings	H - 4
Internal Bearings	H - 4
Power Unit Motor	H - 4
Power Unit Motor/Brake	H - 4
Power Unit Reducer	H - 4
Power Unit Sprockets	H - 4
Power Unit Chains	H - 4
Power Unit Timing Belts	H - 5
Drive Sprockets	H - 5
Drive Pulley and Lagging	H - 5
Supports and Hangers	H - 6
Semi-Annual Maintenance	H - 6
Power Unit Motor	H - 6
Power Unit Reducer	H - 6
External Pulley Bearings	H - 6
Internal Bearings	H - 6
Replacing the Belt(s)	H - 7
Troubleshooting	H - 7

---

**Section I Spare Parts**

General Information	-----	- 1
Intermediate Sections	-----	- 1
Roller Bed	-----	- 1
Slider Bed	-----	- 1
Box Bed	-----	- 1
End Drives	-----	- 2
Series 400 with Take-Up	-----	- 2
Series 600 and 800 with Take-Up	-----	- 2
End Idlers	-----	- 3
Series 400, 600, and 800	-----	- 3
Knife Edge Assembly	-----	- 3
Intermediate Drives	-----	- 4
SA2000 - Intermediate Section	-----	- 4
SA2001 - Intermediate Section - Low Profile	-----	- 5
Auxiliary Take-Up Sections	-----	- 6
Manual (3.5" Pulleys)	-----	- 6
Manual (6" Pulleys)	-----	- 6
Automatic (Air) (6" Pulleys)	-----	- 6
Spring Take-Up	-----	- 7
Upper Bend Sections	-----	- 7
1.9" Rollers	-----	- 7
2.5" Rollers	-----	- 7
Power Units	-----	- 8
Under-hung Mount	-----	- 8
Side-Mounted	-----	- 8
Driven Jackknife	-----	- 9
Non-Driven Jackknife	-----	- 9
Power Feeders	-----	- 10
Incline	-----	- 10
Decline	-----	- 10
Reversible	-----	- 11
Non-Width Related Parts	-----	- 12
Width Related Parts	-----	- 28
Lubricants and Paints	-----	- 32

**Section J Product Index**

Roller Bed ----- J - 1

- Belt Conveyors - Power Feeders, Incline, and Decline ----- J - 1
- Belt Conveyors - Upper Bend ----- J - 1
- Belt Conveyors - Jackknife Non-Drive Units ----- J - 2
- Belt Conveyors - Roller Bed, Idler Units ----- J - 3
- Belt Conveyors - Idler With Upper Bend ----- J - 4
- Belt Conveyors - Roller Bed, Intermediate ----- J - 4
- Belt Conveyors - Roller Bed, Center Take-up Units ----- J - 5
- Belt Conveyors - Roller Bed, End Drive Units ----- J - 6
- Belt Conveyors - End Drive With Upper Bend ----- J - 6
- Belt Conveyors - Roller Bed, End Drive With Jackknife ----- J - 7
- Belt Conveyors - Roller Bed, SA2000 - Intermediate Drive ----- J - 8
- Belt Conveyors - Roller Bed, SA2001 - Intermediate Drive - Low Profile ----- J - 9
- Belt Conveyors - Roller Bed, Complete End Drive 400 ----- J - 10
- Belt Conveyors - Roller Bed, Complete End Drive 600 ----- J - 10
- Belt Conveyors - Roller Bed, Complete End Drive 800 ----- J - 11
- Belt Conveyors - Roller Bed, Complete Center Drive 600 ----- J - 12
- Belt Conveyors - Roller Bed, Complete Center Drive 800 ----- J - 13

Slider Bed ----- J - 14

- Belt Conveyors - Power Feeders, Incline and Decline ----- J - 14
- Belt Conveyors - Upper Bend ----- J - 14
- Belt Conveyors - Jackknife Non-Driven Units ----- J - 15
- Belt Conveyors - Slider Bed, Idler Units ----- J - 16
- Belt Conveyors - Idler With Upper Bend ----- J - 16
- Belt Conveyors - Slider Bed, Intermediate ----- J - 16
- Belt Conveyors - Slider Bed, Center Take-up Units ----- J - 17
- Belt Conveyors - Slider Bed, End Drive Units ----- J - 17
- Belt Conveyors - End Drive With Upper Bend ----- J - 18
- Belt Conveyors - Slider Bed, End Drive with Jackknife ----- J - 18
- Belt Conveyors - Slider Bed, SA2000 - Intermediate Drive ----- J - 19
- Belt Conveyors - Slider Bed, SA2001 - Intermediate Drive - Low Profile ----- J - 20
- Belt Conveyors - Slider Bed, Complete End Drive 400 ----- J - 21
- Belt Conveyors - Slider Bed, Complete End Drive 600 ----- J - 21
- Belt Conveyors - Slider Bed, Complete End Drive 800 ----- J - 22
- Belt Conveyors - Slider Bed, Complete Center Drive 600, 800 ----- J - 23

Box Bed ----- J - 24

- Belt Conveyors - Box Bed, Intermediate ----- J - 24
- Belt Conveyors - Box Bed, Center Take-up Units ----- J - 24
- Belt Conveyors - Box Bed, End Drive Units ----- J - 25
- Belt Conveyors - Box Bed, SA2000 - Intermediate Drive ----- J - 26
- Belt Conveyors - Box Bed, SA2001 - Intermediate Drive - Low Profile ----- J - 27
- Belt Conveyors - Box Bed, Idler Units ----- J - 28

Miscellaneous ----- J - 28

- Belt Conveyors - Belting ----- J - 28
- Belt Conveyors - Belting ----- J - 29

Belt Conveyors - Belt Personnel Guards ----- J - 30

---

## **SECTION A:PRODUCT SUMMARY**

### **Overview**

The Powered Belt Conveyor product line consists of a full line of components including drives, intermediate idlers, power feeders, upper bend units, and belting that may be combined to accommodate any application requirement.

### **CSPS Designation**

BCB - Belt Conveyor Box Slider.

BCR - Belt Conveyor Roller.

BCS - Belt Conveyor Slider.

### **Applications**

Transportation - Horizontal, Incline, and Decline.

### **Widths**

#### **Belt Widths**

12", 18", 24", 30" and 36".

#### **Between Frame (BF) Dimension "W"**

16", 22", 28", 34" and 40" .

### **Intermediate/Idler Sections**

BCB - Box Frame, Slider Belt.

BCR - Channel Frame, Roller Bed.

BCS - Channel Frame, Slider Bed.

Standard lengths - 3', 6', 9'" and 12', other lengths available.

Idler pulley - 3-1/2" diameter with 1" movement for tracking.

Carrier roller centers - 3", 6" and 9".

Return roller centers - 6" (nominal).

### **Carrier and Belt Return Rollers**

G196GH - greased, high-speed.

G196A1 - (ABEC) precision, greased, high-speed.

---

## Intermediate Drives

### **SA2000 Intermediate Drive**

900 lbs. EBP; 8-1/4" diameter lagged pulley; manual take-up and adjustable snub roller.

Under-hung power unit.

### **SA2001 Intermediate Drive - Low Profile Drive**

800 lbs. EBP, 5-7/8" diameter lagged pulley; manual take-up and adjustable snub roller.

Side-mounted power unit.

Field assembled to an Intermediate Section.

## End Drives

### **Series 400**

230 lbs. EBP, 4-1/2" diameter pulley, 3-1/2" diameter take-up pulley.

### **Series 600**

473 lbs. EBP, 6-1/2" diameter pulley, 3-1/2" diameter take-up pulley.

### **Series 800**

688 lbs. EBP, 8-1/2" diameter pulley, 2-1/2" diameter take-up pulley.

All Series have manual take-up and adjustable snub roller.

## Power Units

### **Motors**

1/2 through 7-1/2 HP C-Face (Baldor and Reliance).

Standard and premium efficiency motors.

Brake motors supplied on incline and decline applications.

### **Reducers**

C-Face (Grove and Reliance).

### **Belt Speeds**

30 - 500 fpm.

### **Drive to Pulley**

Chain and/or timing belt drive (depending on speed).

## Power Feeders

Lengths - 3'-0" to 7'-0".

PTO driven from adjoining incline or decline section.

Speed ratios from 1:1 to 1.5:1.

Pivotal adjustment - 10° to 25°.

## Jackknives

Driven and non-driven types with manual take-up.



**Upper Bends**

Adjustable for conveyors from 10° to 25°.

Adjustable roller for belt tracking.

**Auxiliary Take-Ups**

Manual and automatic (air and spring) types.

**Accessories**

Floor supports and ceiling hangers.

Fixed and adjustable side guides.

Traffic controller.

Case deflectors.

**Finish**

Power-coated - Satin Gray.



---

## ***SECTION B: APPLICATION GUIDELINES***

### **Introduction**

#### **Product Line**

The Powered Belt Conveyor provides fully adjustable Power Feeders and Upper Bend Units which accommodate any required angle of incline plus multiple widths, drives, power units, speeds, take ups, etc., that are sized to accommodate any requirements.

The most significant characteristic of the belt conveyor is based heavily on the purpose to which the equipment is to be used - bed type and frame type. These features are described here to provide information for discussions of the applications of the belt conveyor.

The Powered Belt Conveyor is offered in two bed types; slider bed and roller bed, and three frame types; channel, pick belt, and swivel roller. Various combinations of these characteristics serve various functions and product requirements, and adaptations of them can be made to satisfy a wide range of needs.

#### **Functional Capabilities**

The Powered Belt Conveyor serves many functions including:

- Economical powered horizontal transportation conveyor.
- Transports product up and down inclines.
- Handles a wide range of product weights smoothly, gently, and quietly.

#### **Conveyability**

Items weighing up to 100 pounds can be conveyed. Shapes such as unpackaged parts and assemblies, tote pans, cartons, cases, crates, drums, etc. can be carried.

#### **Environmental Considerations**

The Powered Belt Conveyor is designed to operate within normal warehouse and plant temperature and atmospheric conditions. However, certain elements of the equipment can be modified, when necessary, to adapt them to the more demanding requirements of special applications.

---

## Product Description

### Conveyor Side Rails

The formed steel side rails, shown in Figure B - 1, are available in three types:

- Channel Frame (CF)
- Pick Belt (PK)
- Swivel Roller (SR)

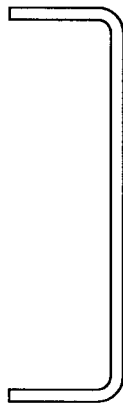

Channel Frame (CF)

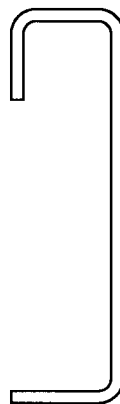

Pick Belt (PK)

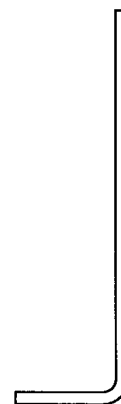

Swivel Roller (SR)

Figure B - 1 Formed Steel Side Rails

#### Channel Frame (CF)

The Channel Frame (CF) side rail is normally supplied as the standard configuration for either slider or roller bed. For roller beds, the rail is punched along the top edge of the vertical portion to receive roller axles. For slider beds, the bed plate is bolted to the side frames.

#### Pick Belt (PK)

The Pick Belt (PK) side rail is similar to the Channel Frame (CF) except it has an additional bend at the top for added strength required in loading areas such as along pick belts. The extra bend also presents a smooth edge to workers stationed along the belt.

#### Swivel Roller (SR)

The Swivel Roller (SR) side rail has a standard channel frame member on one side and one channel-type member without a top flange on the take-away spur side. It is used for high speed sortation conveyor applications (swivel roller type sorter).

## Bed Types

Although the belt is the carrying medium for a belt conveyor, the bed surface on which the belt rides determines many of the characteristics of the belt conveyor unit.

### Slider Bed

The belt of the slider bed conveyor rides on a flat steel plate which provides a solid, smooth, flat surface for the belt and the product being carried. See Figure B - 2 and Figure B - 3. It is most beneficial for supporting irregular product surfaces or products which are quite small or unstable. Available with either formed channel rails or single piece box frame.

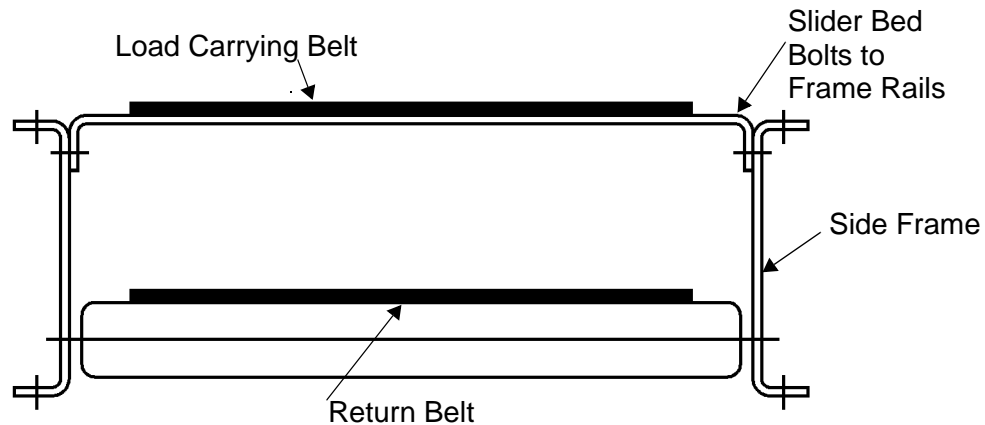

Figure B - 2 Three-Piece Slider Bed (BCS)

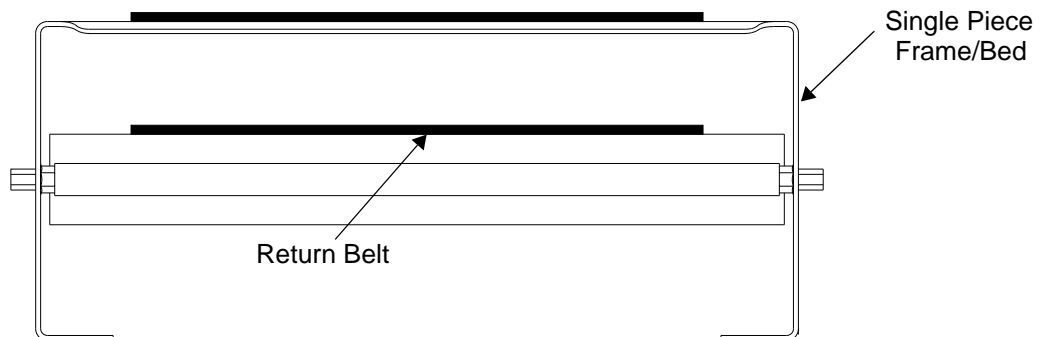

Figure B - 3 Single Piece Box Bed (BCB)

The slider bed design produces a conveyor that is smooth in operation and inherently quiet.

Since there is a relatively large friction content in the belt sliding on the slider bed, this type of unit lends itself more to handling low or medium weight products where friction losses can be a greater percentage of the product weight.

The belt-to-bed friction is advantageous when used on decline units where retarding of the load is partially achieved by the inherent bed friction.

For persons working along side the conveyor, the slider beds provide a solid unbroken table surface on which to work.

---

## Roller Bed

For roller bed belt conveyors, the belt travels on low friction ball bearing rollers. See Figure B - 4. This type is most beneficial for long conveyors or conveyors which are required to handle heavy loads which might otherwise cause belt pulls exceeding the capacity of the conveyor.

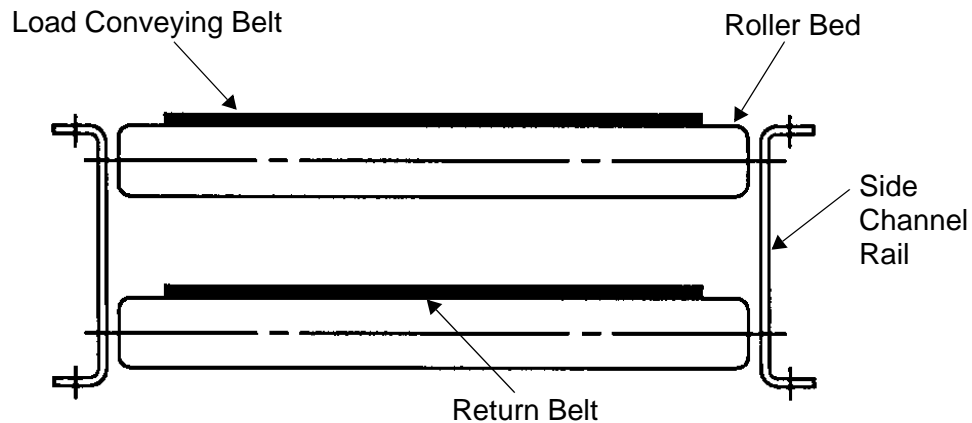

Figure B - 4 Roller Bed Cross Section

The roller bed belt conveyor provides higher load carrying capacity than a slider bed unit of the same horsepower. Or, a roller bed unit can carry the same load a longer distance than a slider bed unit with the same horsepower. For similar loads and conveyor lengths, the roller bed conveyor requires much less horsepower. Roller beds are more costly than slider beds, and roller beds are noisier.

On level conveyors, the center-to-center distance between rollers must be no greater than half the length of the smallest product being carried. For inclined conveyors, the center-to-center roller dimension must be no greater than one third the length of the smallest product

## Equipment Components

### Intermediate Sections

Intermediate Sections are straight sections, without end pulleys, which fill between the terminal end sections. Intermediate Sections are available in slider or roller bed forms and in the standard widths and lengths.

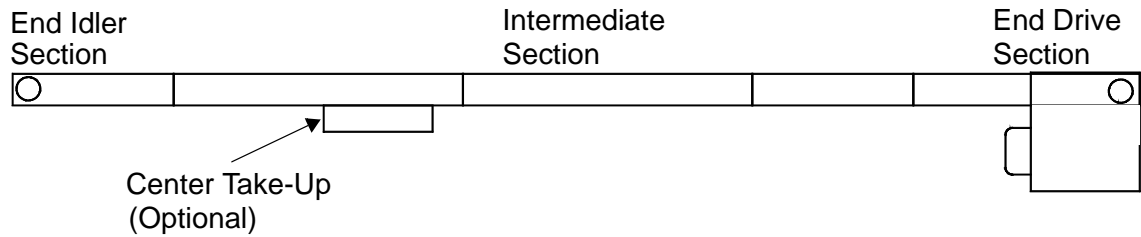

Figure B - 5 Belt Conveyor Example

### End Idler Sections

End Idler Sections are similar to the Intermediate Sections except an end idler pulley is included. See Figure B - 6. End Idler Sections are available with either slider bed or roller bed.

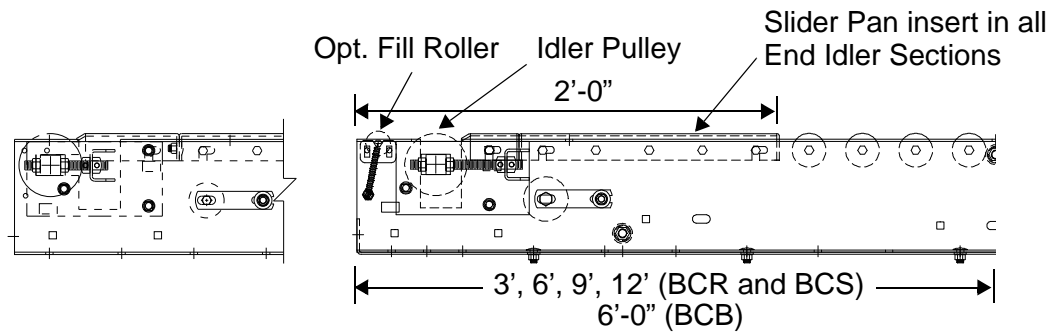

Figure B - 6 End Idler Section

## End Drives

End Drives are used for an economical one-way belt travel toward the drive end. See Figure B - 7. End Drives with internal take-up are available with either under-hung or side-mounted power units. A 4' Intermediate Section with a 2' End Drive provides a 6' conveyor section.

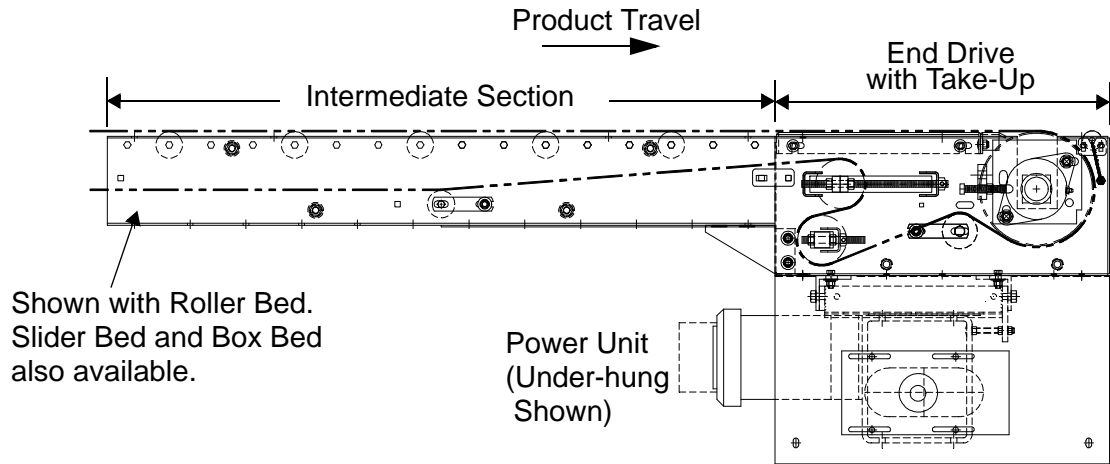

Figure B - 7 End Drive Section



**Intermediate Drives**

Intermediate Drives are used for two way travel applications or when small end pulleys are required. The design allows attachment to an Intermediate Section.

Two types of Intermediate Drives are available:

- SA2000 Intermediate Drive, see Figure B - 8
- SA2001 Intermediate Drive - Low Profile, see Figure B - 9

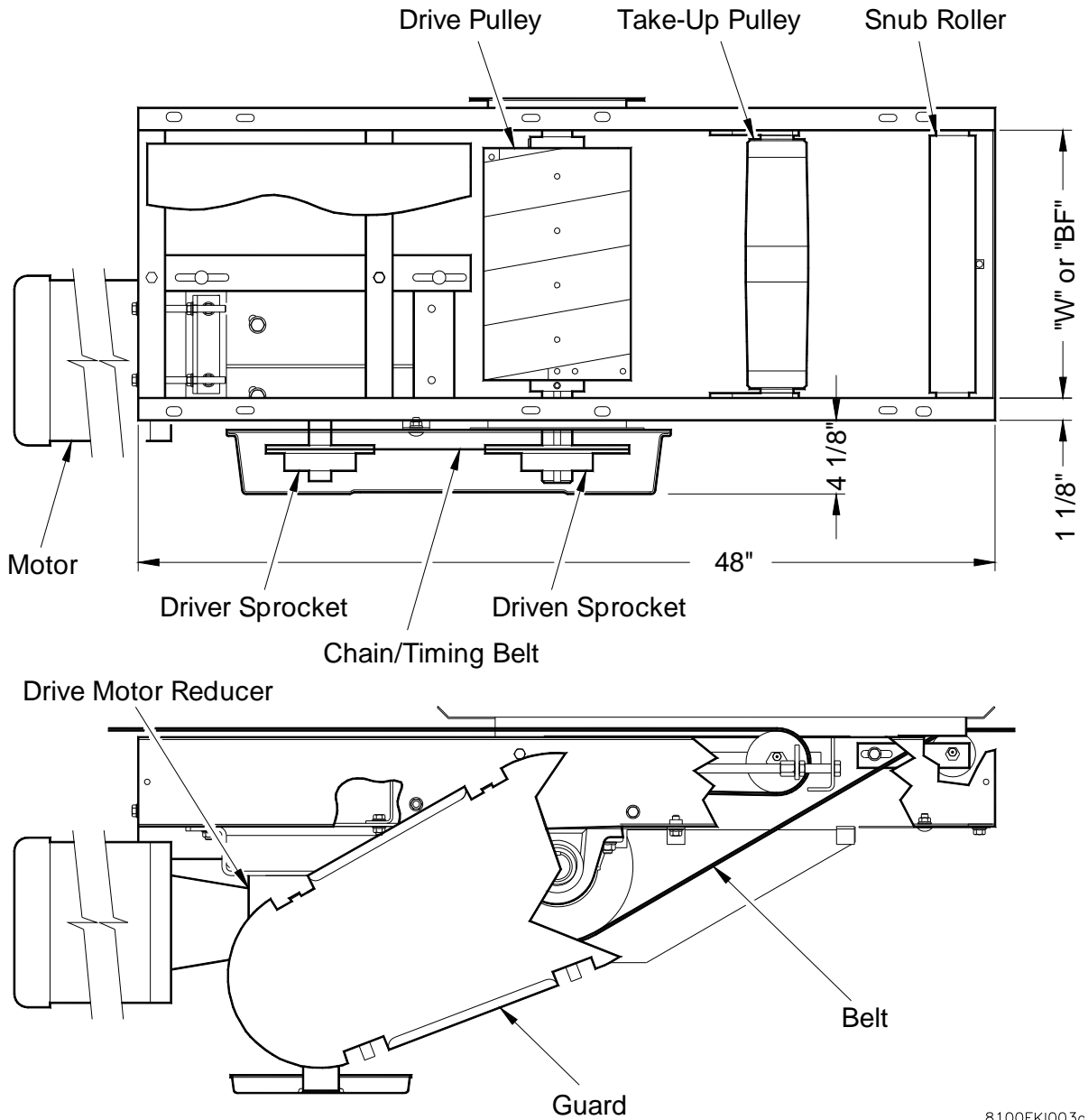

8100FKI003c

Figure B - 8 SA2000 Intermediate Drive

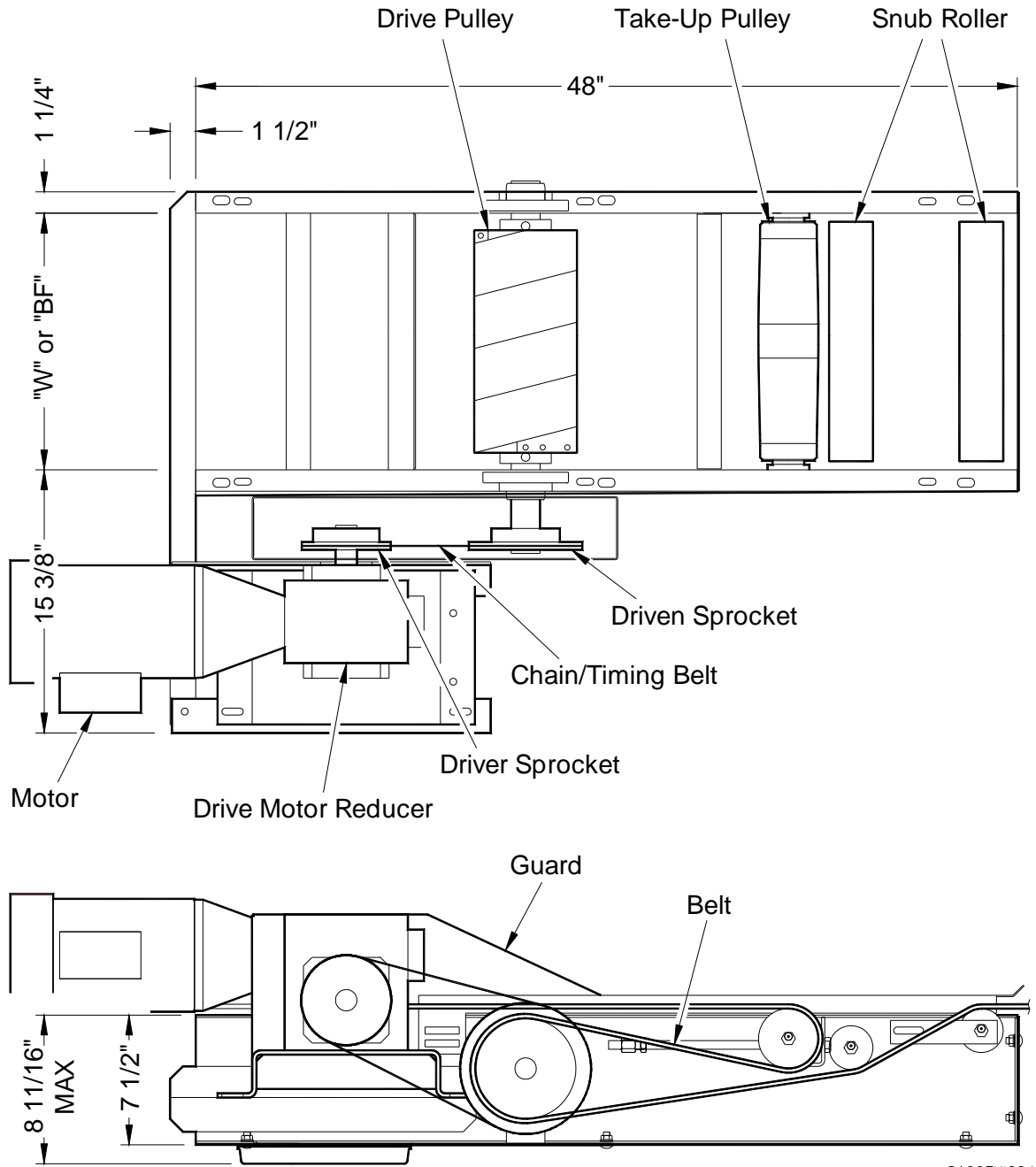

Figure B - 9 SA2001 Intermediate Drive - Low Profile

## Driven Jackknife Sections

Driven Jackknife Sections are similar to standard End Drives but contain a 2' End Drive for connection to an adjoining “downstream” conveyor. See Figure B - 10. Power for the additional End Drive pulley is transferred from the end pulley shaft of the End Drive by connecting the two shafts with a chain and sprockets.

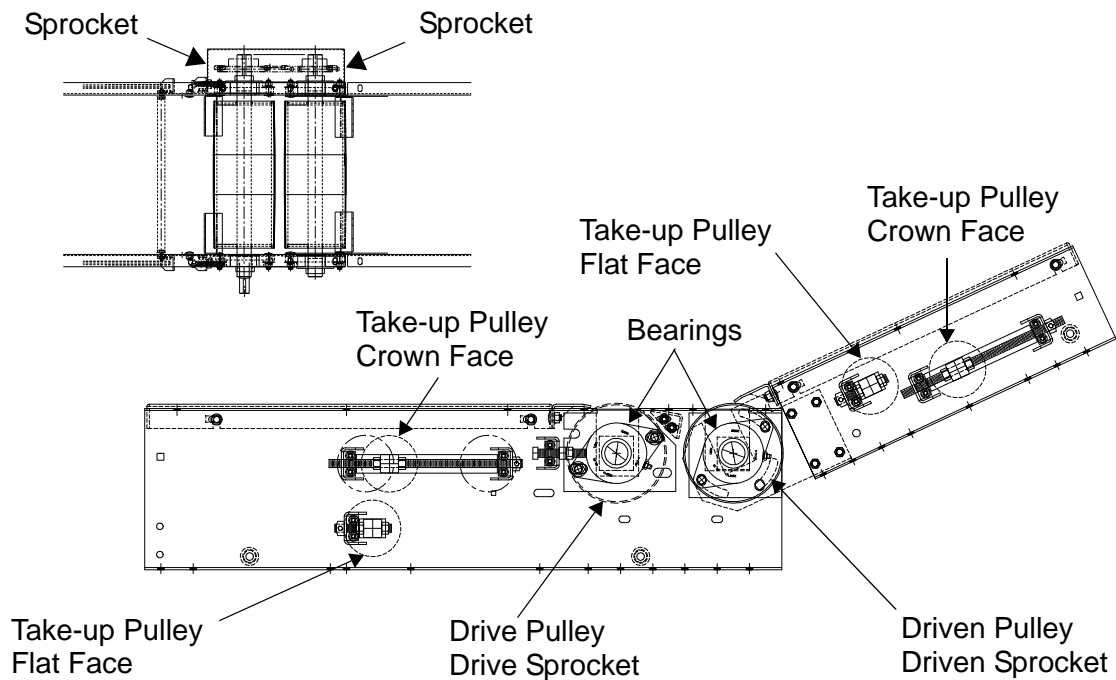

Figure B - 10 Driven Jackknife Section

## Power Units

Power Unit assemblies include the motor, reducer, and chain drive with either a side type or an underhung mounting frame. The motor is supplied with a brake for incline or decline applications. Standard speeds range from 30 to 500 fpm.

## PTO Connections

PTO (Power-Take-Off) assemblies refer to the transfer of driving power from a unit which has a power unit to a unit without a power unit. The units may be similar in type, belt to belt, or dissimilar, as belt to live roller. The arrangement saves a power unit and allows close control over the relative speeds.

PTO's are supplied as follows:

**End Idler Section** - A lagged drive pulley replaces standard idler pulley to provide power to adjoining upstream or downstream “driven” conveyor.

**End Drive** - A drive pulley with double shaft extension replaces the standard End Drive pulley to provide power to adjoining downstream “driven” conveyor.

## Power Feeder Units

Power Feeder Units consist of a 3', 4', or 7' horizontal conveyor with a PTO connection to a 2' End Drive. They are specifically designed to be used in one of three flow situations: incline, decline, or reversing.

With the complete conveyor unit acting as the powered tail when the End Drive is attached to the sloped bed, the three possible arrangements and the PTO differences are as follows:

- For an inclined unit, the power tail feeds the ascending conveyor; the two PTO pulleys should lie in the same plane as the Power Feeder.
- For a declining unit, the two PTO pulleys should lie in the same plane as the descending unit.
- For a reversing arrangement, the two PTO pulleys should be positioned with an in-between relationship. The extended planes of the two beds should intersect at a point midway between the two PTO pulleys.

## Non-Driven Jackknife Sections

Non-Driven Jackknife sections are essentially PTO connections that are used when Power Feeders are required with non-standard lengths (NOT available for “reversing” applications).

## Auxiliary Take-Ups

Auxiliary Take-Ups are available; one manually operated by screws, the other automatically operated by air or spring. An Auxiliary Take-Up is used to supplement the built-in take-up in a drive unit when the conveyor is long and the belt stretch exceeds the capability of the standard take-up. Table B 1 shows the maximum conveyor length recommended when using standard take-up components.

Table B 1: Maximum Conveyor Length per Take-Up Component(s)

Take-Up Components				Drive Type			
With Drive		Auxiliary		End		Intermediate	
End	Intermediate	Manual	Auto	400	600/800	SA2000	SA2001
Style 1/3 Conveyors with End Drive							
X	-	-	-	80 ft.	80 ft.	-	-
X	-	X	-	160 ft.	160 ft.	-	-
X	-	-	X	-	*400 ft.	-	-
Style 2/4 Conveyors with Intermediate Drive							
-	X	-	-	-	-	120 ft.	120 ft.
-	X	X	-	-	-	200 ft.	200 ft.
-	X	-	X	-	-	*400 ft.	*400 ft.
*Maximum recommended conveyor lengths.							

## Upper Bend Units

Upper Bend Units provide the curved transition between two sections, one sloped and the other horizontal. See Figure B - 11. The angle of an Upper Bend Unit can be adjusted between 10° and 30°. Whether applied to a slider or roller bed unit, the belt rides on either 1.9" rollers (medium duty) or 2.5" rollers (heavy duty).

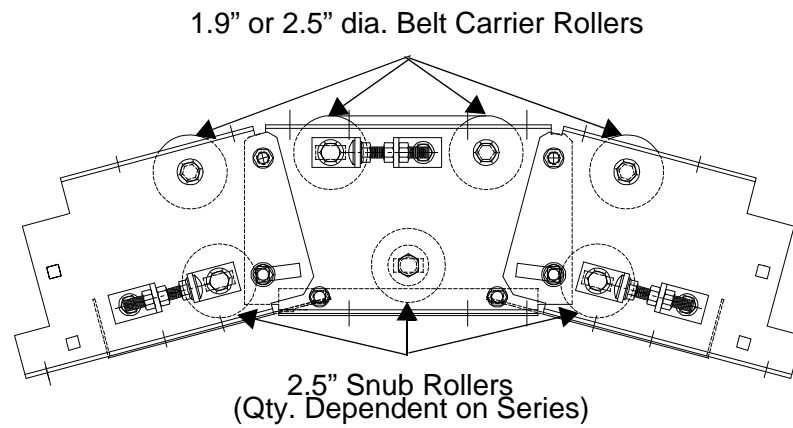

Figure B - 11 Upper Bend Unit

# Applications

## Styles

Combinations of the equipment elements are quite varied and almost endless. Four general conveyor styles are available. See Figure B - 12.

See "Installation Procedures", on page G - 1, for all of the Powered Belt Conveyor styles available.

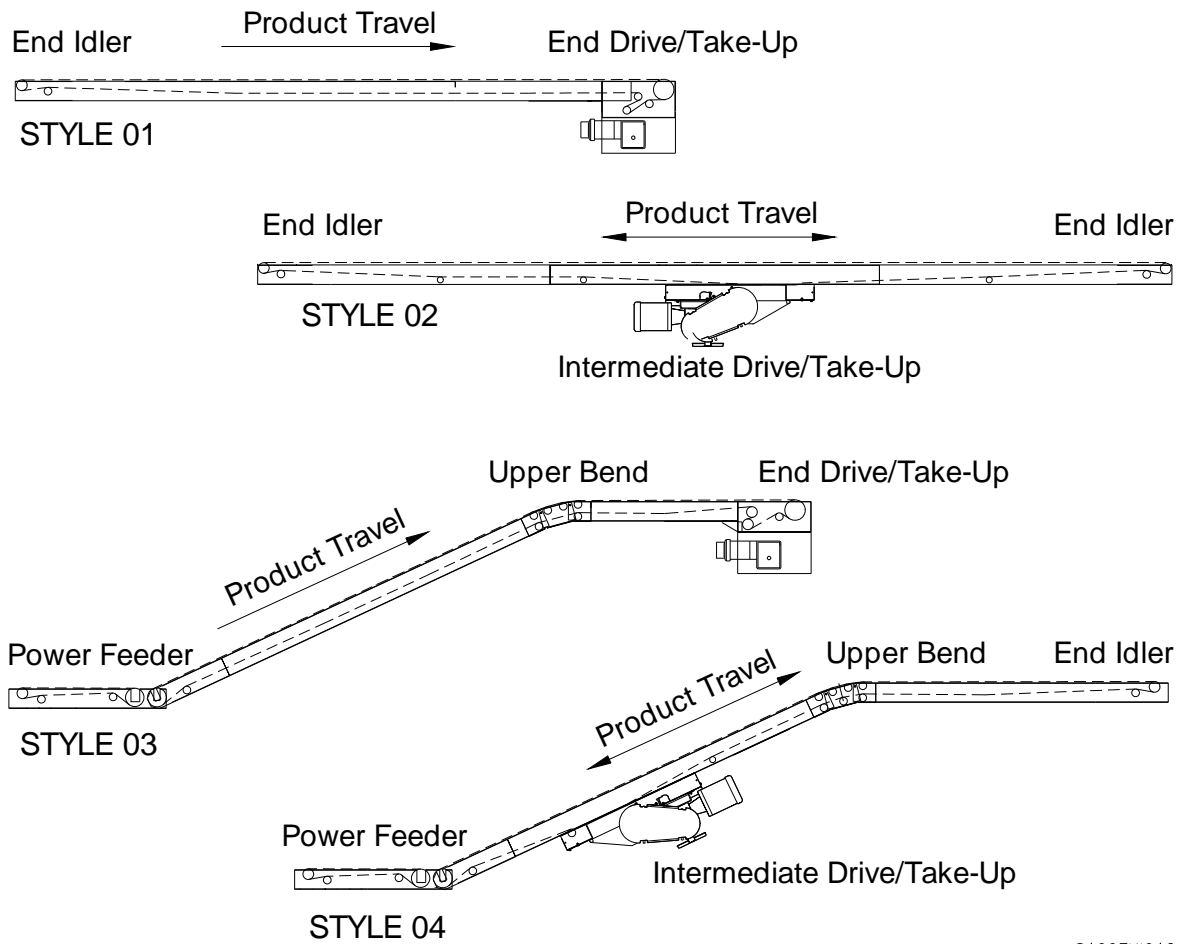

8100FKI012a

Figure B - 12 General Powered Belt Styles

---

## Transportation

### Horizontal

Horizontal transportation of products is one of the most elementary functions of powered belt conveyors.

Horizontal conveyors usually consist of two terminal end sections connected by the required number of Intermediate Sections to fill out the distance to be covered. If the unit is to be reversible, an Intermediate Drive should be used and should be located near the center of the unit. For units traveling in only one direction, an end drive can be used at the discharge end of the unit.

The choice of a speed for the belt unit will usually depend on the number of product units to be delivered per minute (called throughput). Multiplying throughput by the feet of belt per product unit gives the minimum belt speed to handle the load. Note that the "feet of belt per product unit" should represent the center-to-center distance between uniformly spaced cartons. Also note that 300 ft./min. belt speed is approximately equal to 3-1/2 miles/hour, which is about the speed of a good brisk walk.

The live load on the conveyor at any one time can be calculated or estimated if the product unit weight (W), throughput (R), conveyor length (L), and belt speed (S) are known. The product of the first three divided by the belt speed yields the total live load (W). If the (W) exceeds the live load capacity of the available drives, then the required unit length can be divided into two or more shorter lengths which can be handled by available drive packages.

Another way of reducing the load on the drive is to reduce the throughput rate, either by limiting the rate at which products are fed to the belt conveyor or by increasing its speed. Neither of these actions will reduce the inherent dead load of the belt unit, but both will reduce the number of products on the unit at one time, thereby reducing the belt pull. There are trade offs, however. Reducing the charge rate reduces the overall throughput of the system. While increasing the belt speed does maintain the overall throughput, it also increases the horsepower requirement.

### Incline/Decline Units

Incline and Decline Units transport products from one elevation to another along a slope. To reliably maintain control of the product on slopes, rough top belting is used on the sloped portion of the conveyor. Also, brakes are used on power unit motors.

### Accessories

When a belt conveyor is in series with another conveyor, fill rollers are available to fill the space between end pulleys and to provide smooth transitions for small packages. Standard supports are available, as are side guides.

## Design Criteria

### Slope Angle

The steepest angle (see Figure B - 13) at which items will convey safely and reliably depends on:

- The length/height ratio of the product
- The weight distribution within the product
- Belt traction

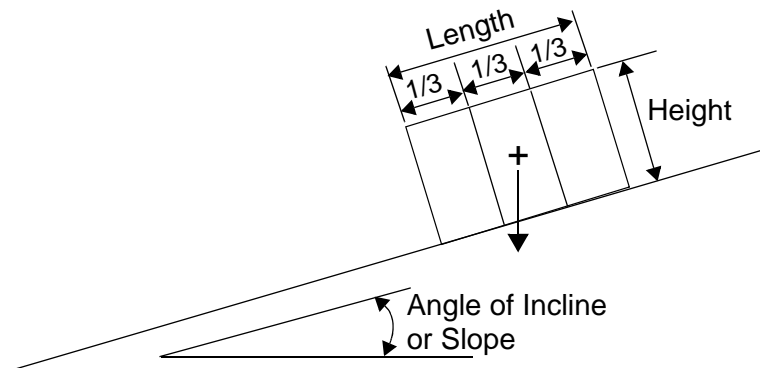

Figure B - 13 Slope Angle

A good rule of thumb is that the maximum angle at which a product will reliably convey is such that the height of the product (perpendicular to the carrying surface) and length of the product (parallel to the direction of travel) should permit a vertical line (drawn from the center of the load) to fall within the middle third of the product's base length, which is contacting the carrying belt.

The illustration in Figure B - 13 assumes that the weight of the conveyed item is uniformly distributed within the conveyed container. If an item is top-heavy or the weight is concentrated to the front or the rear, then the point from which the line is dropped will have to be moved accordingly.

The maximum angle of incline is limited by the ability of the conveyor belt to move items without slippage. Twenty-five degrees is considered to be the maximum angle for conveying cartons when using standard belting on inclined conveyors. Plastic tote pans and other smooth-bottomed items may have to be carried at lesser angles.

If space is at a premium, the inclined belt conveyor should be laid out using the steepest possible safe angle determined by the above criteria to make the horizontal projected length of the unit as short as possible. However, if space will allow, reduce the slope angle and lengthen the unit, allowing the unit to handle the unstable product.

### Power Feeders

The next item in the selection of equipment is whether there should be a Power Feeder at either end.

At the lower level of an inclined conveyor, a Power Feeder provides a smooth and positive transfer of product between the inclined conveyor and horizontal conveyor. For a transfer of product across the junction, the correct Power Feeder type should be selected: incline, decline, or reversing.



---

If this unit is to be unidirectional, the correct feeder, incline or decline, with speed differential will assist products to negotiate the junction without product bridging.

---

**Note:** Bridging is a term used to describe the result of a second product pushing against a first product with such force that the two act like one product while negotiating a junction, thereby creating a “bridge” across the junction. See Figure B - 14.

---

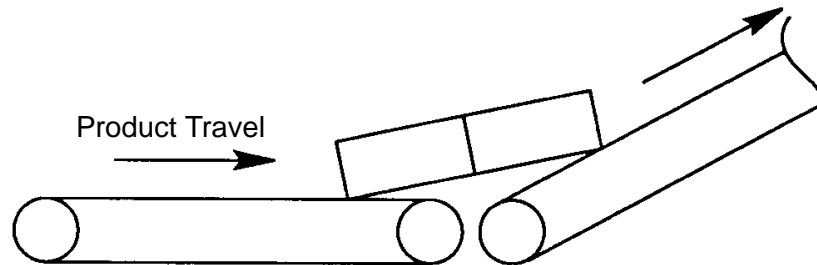

Figure B - 14 Product Bridging

Bridging is avoided by running the portion of the belt unit which is receiving product from the junction at a speed faster than the portion which is feeding the junction. In this manner, a gap is pulled between products as they negotiate the junction, preventing product bridging.

For a reversing unit, the powered feeder will run at the same speed as the sloped portion.

#### **Drive Package**

When choosing the type and location for the drive package, consider the direction of belt travel. For a reversing conveyor, locate an Intermediate Drive on the sloped portion of the bed near the center of the unit. However, if there is a long horizontal runout section at the upper level, an Intermediate Drive should be located near the Upper Bend Unit.

For a single direction conveyor, an End Drive can be used at the discharge end. If that happens to be the upper level, a combination End Drive with attached Upper Bend Unit can be applied. Or, the End Drive and Upper Bend Unit can be installed individually.

#### **End Idler(s)**

An End Idler is used to redirect the belt along its return run at the end of a conveyor.

#### **Upper Bend**

Upper Bend Units provide a “curved” transition between the sloped bed and the horizontal runout at the upper level. This assembly can be inserted between the other belt sections, or it can be included as part of the upper runout or End Drive assembly. The Upper Bend Unit is adjustable between 10° and 30°, and contains rollers in the bed surface to reduce the drag on the belt going over the curve.

#### **Belt Type**

For the purpose of controlling the loads on the slope, a rough top belt is used.

---

## Braking

Another common use for a horizontal belt conveyor is that of providing a braking function. See Figure B - 15. With assistance from a brake motor in the drive, the belt unit holds back products that are to be released from an accumulation conveyor or other feeding conveyor. When the belt is stopped, products back up on the accumulation conveyor. The build-up of line pressure usually causes items to slide on the belt (rough top recommended) until there are enough items on the belt so that their total weight and friction can resist the line pressure. When the brake belt is restarted, the products are released.

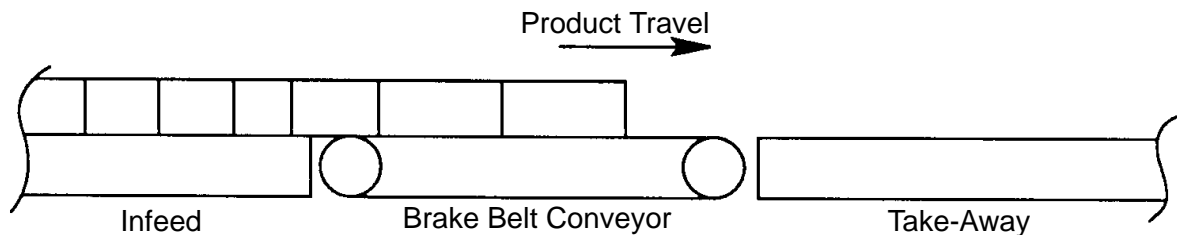

Figure B - 15 Brake Belt Conveyor

The brake belt speed should equal the package length (feet) multiplied by the desired throughput rate (products per minute). If this speed gives a faster delivery rate than the discharge rate of the accumulation line, gaps between the products will appear after the start-up slug has been discharged.

The required length of the brake belt depends on the amount of product being held back and the type of accumulating conveyor being used.

**SECTION C: STANDARD SPECIFICATIONS**

**Frame Assemblies**

**Frame Rails**

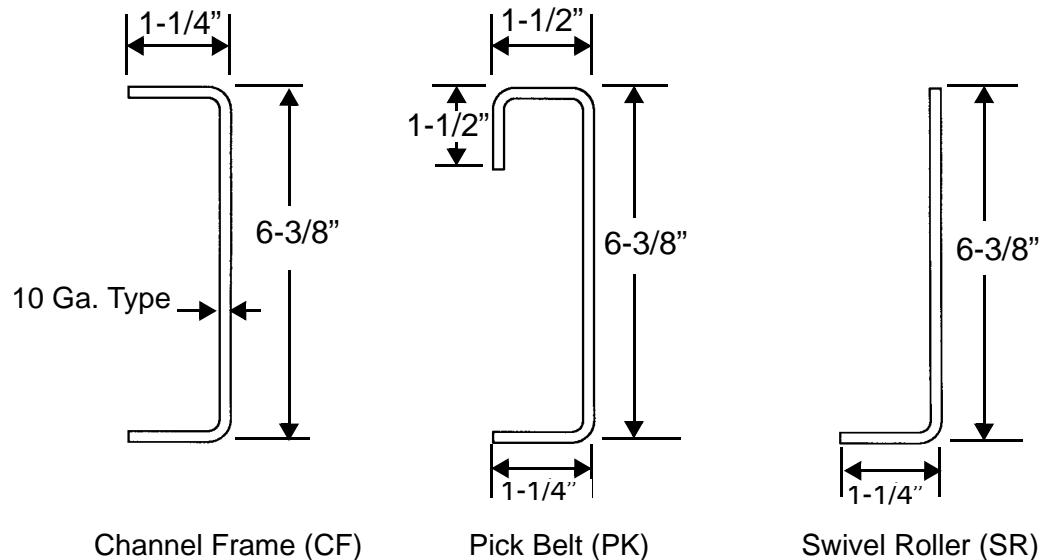

Figure C - 1 Frame Members

**Channel Frame (CF) Type**

Standard - CF type frame.

6-3/8" x 1-1/4" x 10 ga. formed channel. 100 lbs./ft. live load capacity.

**Pick Belt (PK) Type**

Optional - PK type frame.

Same as the CF type except channels are formed with 1-1/2" x 1-1/2" double-bend top flanges.

**Swivel Roller (SR) Type**

Optional - SR type frame.

Same as the CF type except frame rail on one side has no top flange.

## Beds

### Slider Type

12 ga. galvanized steel pan inserts with formed flanges in all sides, bolted to frame side rails. Bolted cross members at bottom of frame rails.

### Roller Type

Frame rails punched on 3" centers for captive rollers. Bolted cross members at top and bottom of frame rails.

### Box Bed Type

6-5/8" deep x 12 ga. (galvanized) formed one piece, integral frame and slider bed. Bolted cross members.

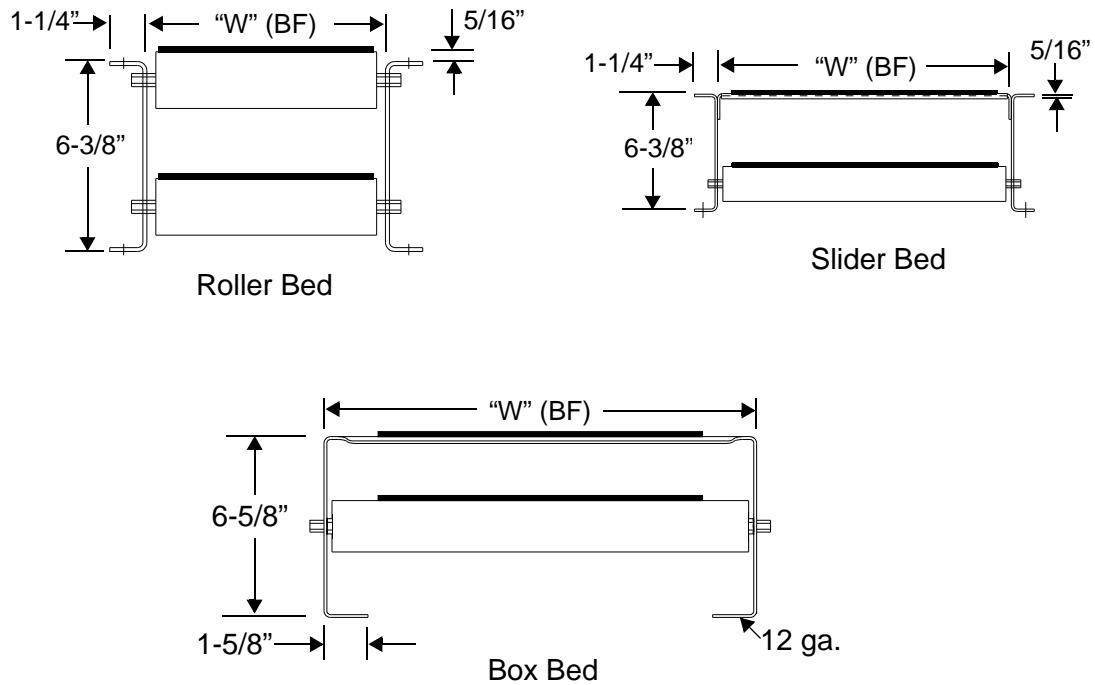

Figure C - 2 Roller Bed and Slider Bed

## Intermediate Section

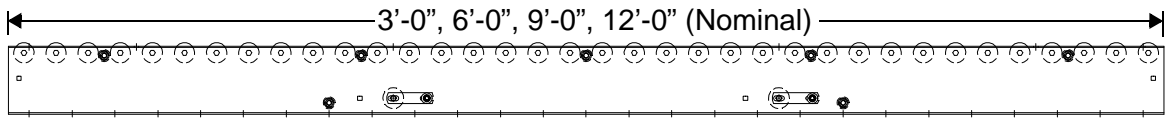

Figure C - 3 Roller Bed Intermediate Section

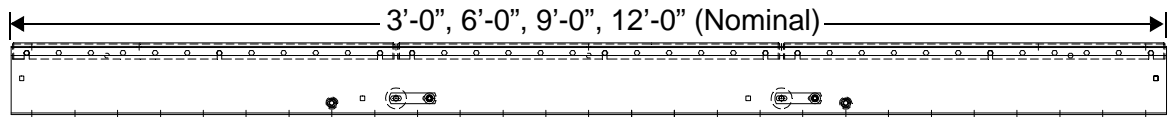

Figure C - 4 Slider Bed Intermediate Section

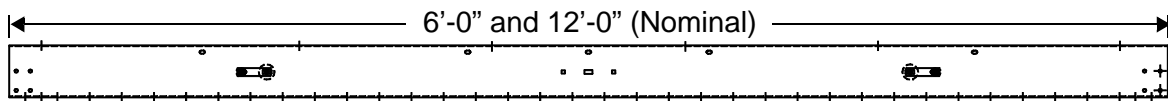

Figure C - 5 Box Bed Intermediate Section

### Widths “W” (BF)

“W” (BF) = 16”, 22”, 28”, 34”, and 40”. Belt width is “W” minus 4”.

### Lengths

3'-0”, 6'-0”, 9'-0”, and 12'-0”.

Note: (BCR/BCS only) Actual length is 1/8” less than stated length.

Example: A 12'-0” long section is actually 11'-11-7/8”.

### Beds

Box, Slider, or Roller type.

### Belt Return Rollers

At nominal 6’ centers; adjustable for belt tracking.

### Carrier and Belt Return Rollers

G196GH - 1.9” diameter x 16 ga. galvanized with spring-loaded 7/16” hex CRS shaft and greased bearings.

G196A1 - 1.9” diameter x 16 ga. galvanized with spring-loaded 7/16” hex CRS shaft and ABEC bearings.

## End Idler Section - BCR and BCS

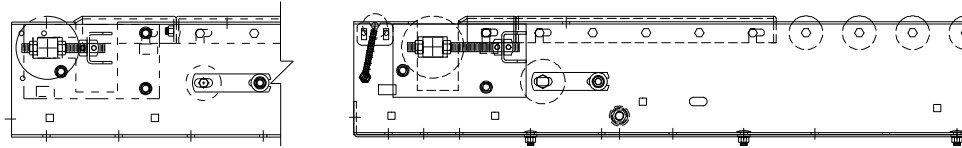

Figure C - 6 End Idler Section

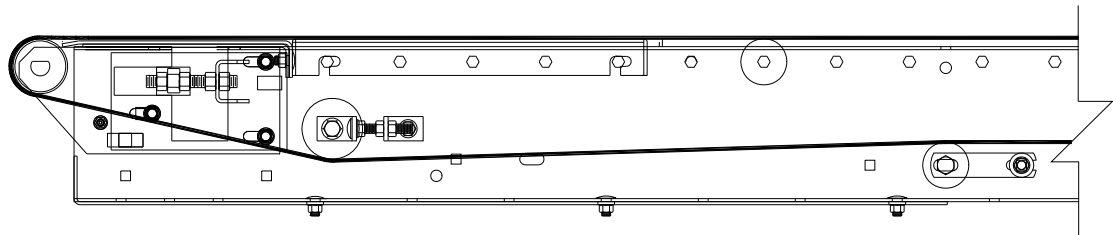

Figure C - 7 End Idler Section - Knife Edge Assembly

### Frame

CF Type (standard) or PK Type (optional) Side rails with powder coated slider pan insert in first 2'-0" of section adjacent to idler pulley and bolted cross members. Protective fill plates mounted immediately adjacent to the idler pulley to minimize the gap between the belt and pulley.

### Bed

Slider or Roller type.

### Lengths

3'-0", 6'-0", 9'-0", and 12'-0".

### Idler Pulley

3-1/2" diameter edge crowned with 1-1/8" non-rotating square shaft and precision, removable, grease packed, and sealed ball bearings. Manual adjustment (1" movement) for belt tracking.

### Knife-Edge

2-1/4" diameter edge crowned with 3/4" diameter non-rotating CRS shaft and internal grease packed precision (ABEC) ball bearings. Manual adjustment (1" movement) for belt tracking.

### Snub Roller

G251AB - 2-1/2" diameter galvanized with retained 11/16" hex CRS shaft and ASQ6503 precision (ABEC) grease packed and sealed ball bearings.

### Fill Roller (Optional)

G131P - 1-5/16" diameter x 14 ga. galvanized tubing with 3/8" hex CRS shaft and 3265P conventional, removable, plain ball bearings. Mounted in slotted mounting clip. Safety cable label attaches to axle and frame. Not available with Knife Edge Idler Pulley.

## Intermediate Drives

Intermediate Drives are available in two types; SA2000, and SA2001 Low Profile.

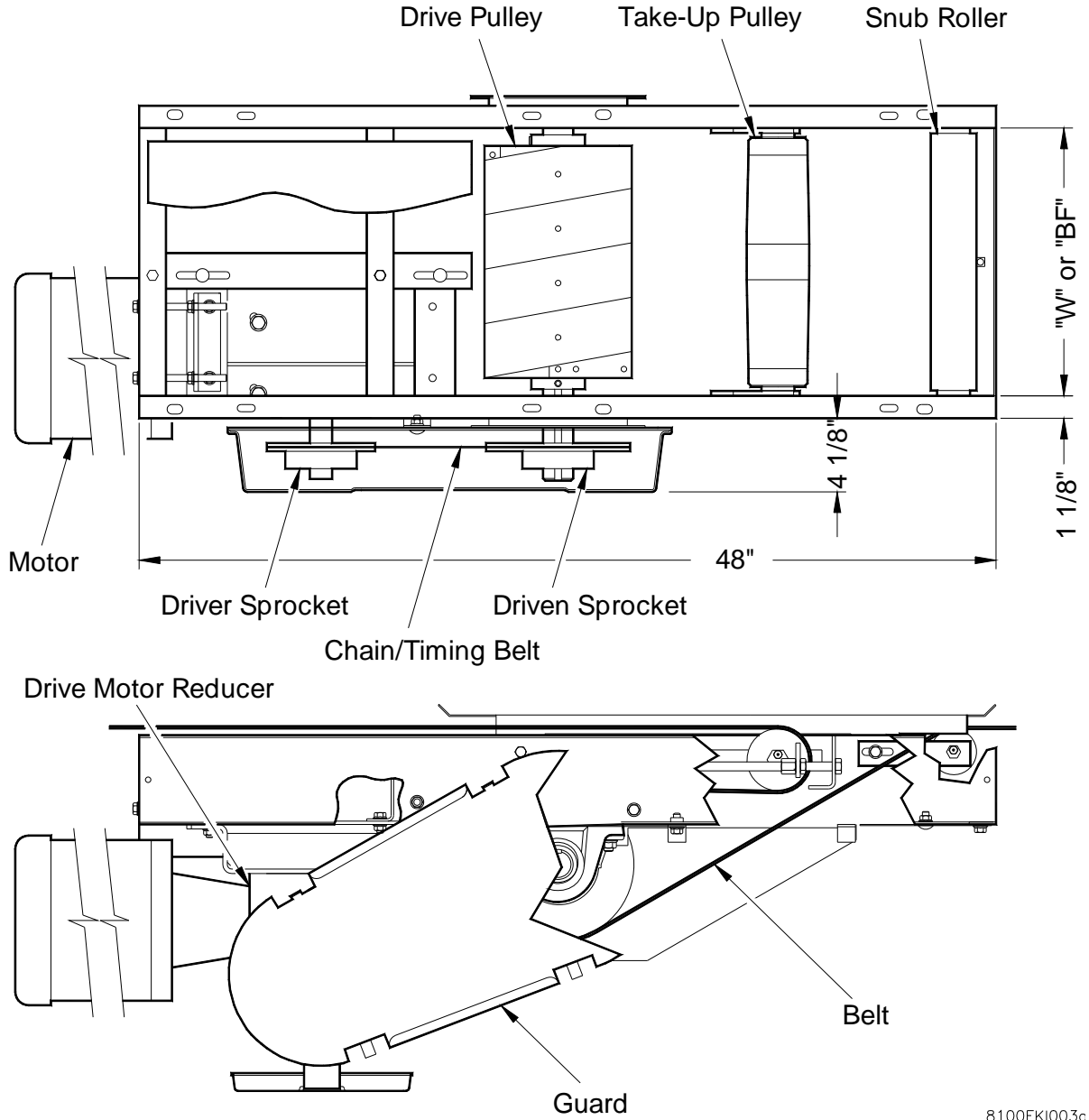

8100FKI003c

Figure C - 8 SA2000 Intermediate Drive

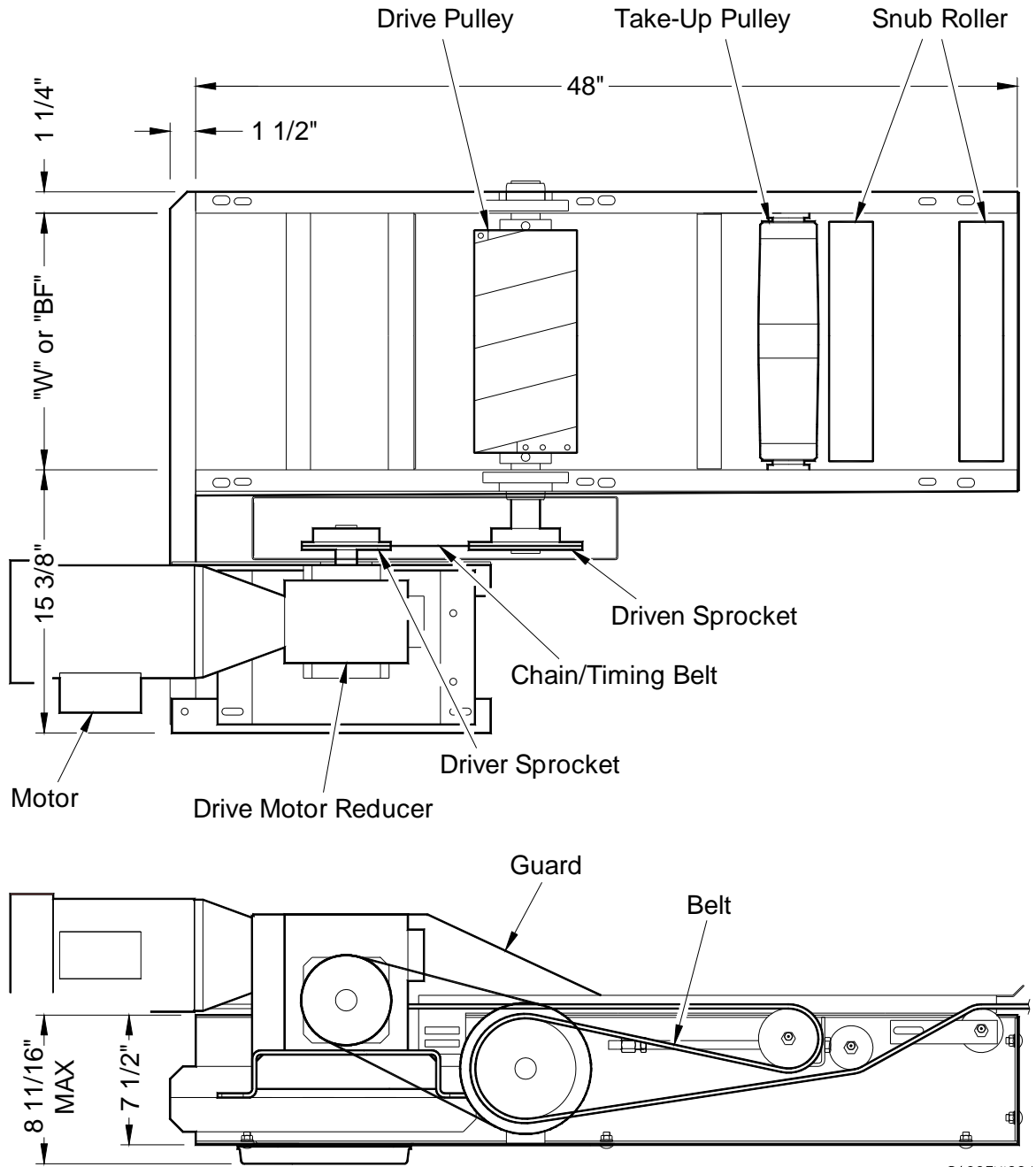

Figure C - 9 SA2001 Intermediate Drive - Low Profile



**Frame**

SA2000 - 5" deep x 48" long x 10 ga. Formed steel side rails with welded cross members and integral motor mounting.

SA2001 - 7-1/2" deep x 48" long x 10 ga. Formed steel side rails with welded cross members and integral motor mounting.

**Drive Pulley and Shaft**

SA2000 - 8-1/4" diameter straight faced lagged pulley with 1-11/16" diameter shaft and pre-lubricated pillow block bearings.

SA2001 - 5-7/8" diameter straight faced lagged pulley with 1-11/16" diameter shaft and flange bearings.

**Bearings**

All bearings are grease packed.

**Snub Roller**

2-9/16" diameter rollers with 11/16" diameter hex axle and B1150 bearings.

**Take-Up Roller and Shaft**

3-1/2 diameter crowned roller with 10" adjustment (20" belt), 1-1/16 hex axle and B11160 bearings.

**Capacity**

SA2000 - 900 lbs. effective belt pull.

SA2001 - 800 lbs. effective belt pull.

**Mounting**

Intermediate Drives must be bolted to the bottom flanges of an Intermediate Section.

For horizontal conveyors they should be mounted so that the return run of the belt is "pulled" around the drive pulley first.

For incline/decline conveyors they should be mounted so that motor is located on the "uphill" side of the reducer. This is opposite the preferred "level" position but is necessary to ensure proper reducer lubrication.

**Safety Guarding**

Sprockets, chain (or timing belt), and return belt are totally enclosed for safety. Drive and Take-Up pulleys are guarded below.

**Width "W" (BF)**

16", 22", 28", 34" and 40".

**Belt Width**

12", 18", 24", 30" and 36" ("W" less 4")

---

## General Information

For one-way travel, an Intermediate Drive should be located near the discharge end of all Style 2 (horizontal) and Style 4 (inclined) conveyors and their modified variations.

An Intermediate Drive designation (RH or LH) refers to the side of the conveyor (horizontal or decline) on which the power unit and chain drive are located as seen when looking in the direction of travel.

For ascending incline conveyors, the RH or LH assembly designation of the Power Unit and Intermediate Drive is opposite that of the observed location when looking in the direction of travel. For example, a chain drive located on the right hand side of the conveyor (looking in the direction of travel) is called out as a LH assembly.

**End Drives**

**End Drives with Take-Up**

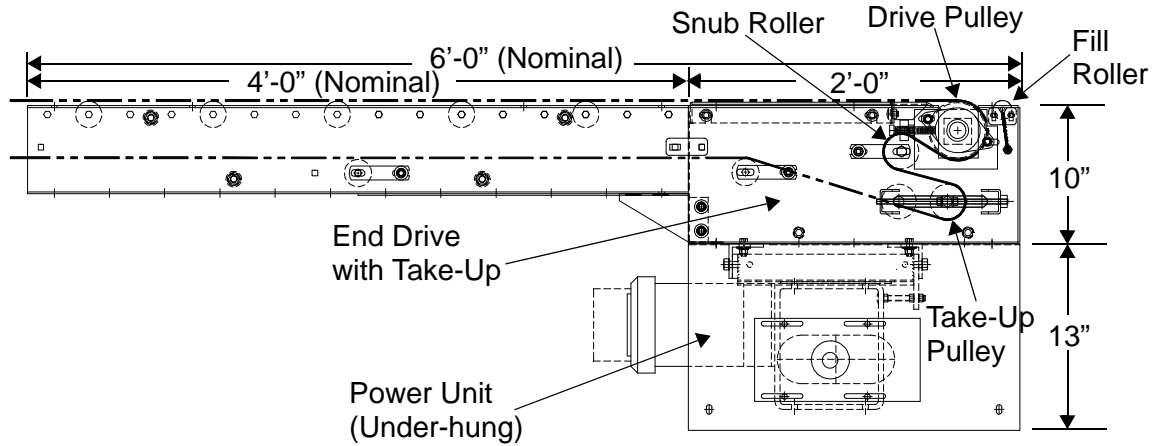
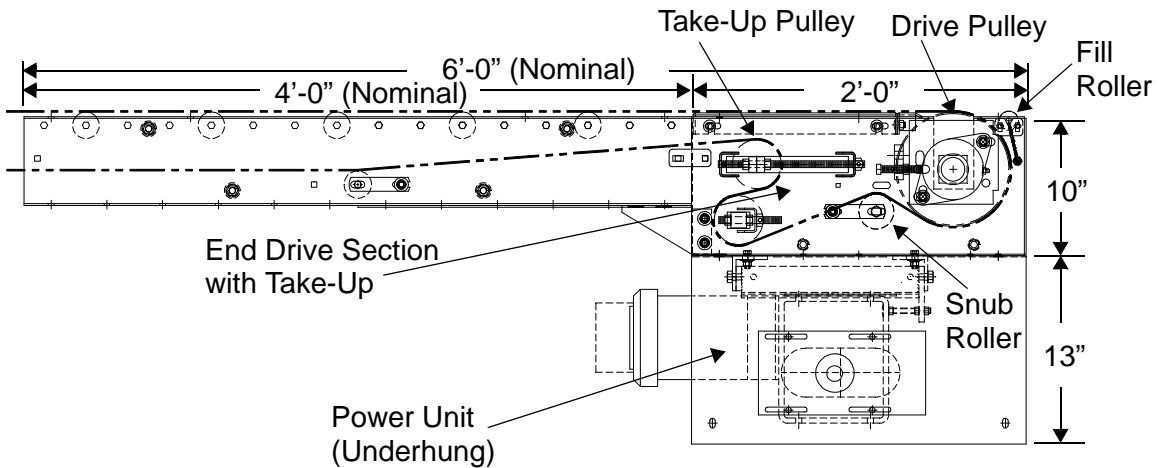

Figure C - 10 End Drive with Take-Up - Series 400



(Series 800 Shown)

Figure C - 11 End Drive with Take-Up - Series 600 and 800

**Drive Frame**

2' long x 10" deep x 10 ga. formed steel side plates with powder coated slider pan insert and bolted cross members. Protective fill plates are mounted immediately adjacent to drive pulley to minimize the gap between the belt and pulley. Assembled with 4'-0" Intermediate Section (CF/PK frame with Roller/Slider bed or Box bed) for 6'-0" drive section length or with an Upper Bend Unit.

**Drive Pulley and Shaft**

Edge crowned with spiral wrapped lagging and welded (turned, ground, and polished) drive shaft; single or double shaft extension. Flange mounted precision ball bearings (grease packed/re-lubricatable).

## Pulley/Shaft Diameters

Series 400 - 4-1/2"/1-3/16"

Series 600 - 6-1/2"/1-7/16"

Series 800 - 8-1/2"/1-11/16"

## Idler/Take-Up Pulley/Shaft

Series 400 - Two G251ASQ with extended shaft for attaching TU screws. Manual adjustment (6" movement). See "End Idler Section - BCR and BCS", on page C - 4, for details.

Series 600 and 800 - Two 3-1/2" diameter; one flat-faced and one edge crowned. Manual adjustment (7-1/2" movement). See "End Idler Section - BCR and BCS", on page C - 4, for details.

## Snub Rollers

Series 400 - Two G196AB, 1.9" diameter x 16 ga. galvanized with 7/16" hex CRS shaft and ASQ6203 (precision, grease packed, and sealed) ball bearings.

Series 600 and 800 - Two G251AB. See "End Idler Section - BCR and BCS", on page C - 4, for details.

## Fill Roller

G131P. See "End Idler Section - BCR and BCS", on page C - 4, for details.

## End Drive with Driven Jackknife

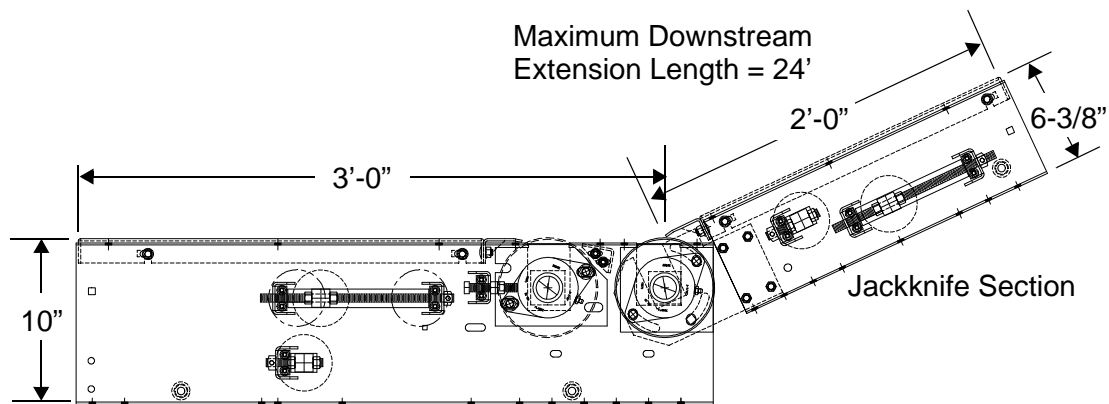

Figure C - 12 End Drive with Driven Jackknife Section

Same as Series 600 - End Drive with Take-Up and PTO connection to adjoining downstream drive/take-up unit. Adjustable from -10 to +25 degrees.

---

## Power Units

### Motor

1/2 through 7-1/2 HP - C-Face TEFC (Baldor or Reliance).

SA2000 and SA2001 Chain Drive - 1/2, 3/4, 1, 1-1/2, 2, and 3 HP (Baldor or Reliance).

SA2000 and SA2001 Timing Belt Drive - 1/2, 3/4, 1, 1-1/2, 2, 3, 5, and 7-1/2 HP (Baldor or Reliance).

Solenoid actuated brake motor supplied on all incline/decline conveyors.

Standard - 230/460VAC - 3PH - 60HZ.

Optional - 575VAC - 3PH - 60HZ and 115VAC - 1PH - 60HZ.

### Reducer

C-Face, Right Angle Worm Gear (Grove or Reliance).

5:1 to 60:1 ratios.

### Speeds

Series 400, 600, and 800 End Drives - 30, 45, 60, 75, 90, 120, 150\*, 180, 200, 250, 300, 350 and 400 fpm.

\* 150 fpm maximum for Series 400.

SA2000 and SA2001 Chain Drive -30, 45, 60, 75, 90, 105, 120, 135, 150, 165, and 180 fpm.

SA2000 and SA2001 Timing Belt Drive - 30, 45, 60, 75, 90, 105, 120, 135, 150, 165, 180, 200, 225, 250, 275, 300, 325, 350, 375, 400, 425, 450, 475 and 500 fpm

### Chain Drive

Series 400, 600, and 800 - RC50, RC60, RC80 and RC100 (all speeds).

SA2000 and SA2001 - RC60 (up to 180 fpm).

### Chain Sprockets

Series 400 - RC50, bored and keyed Type B hub, hardened teeth

Series 600 and 800 - RC60, RC80, and RC100, keyed Taper-Lock hubs, hardened teeth or bored and keyed Type B hubs depending on speed/horsepower requirements.

SA2000 and SA2001 - RC60, keyed Taper-Lock hubs, hardened teeth.

### Timing Belt Drive

SA2000 and SA2001 - 8mm/14mm (all speeds).

### Timing Belt Sprockets

SA2000 and SA2001 - 8mm / 14mm keyed Taper-Lock hubs.

### Power Unit Mounting

Series 400, 600, and 800 End Drives - Optional under-hung or side-mount.

SA2000 - Under-hung mount (only).

SA2001 - Side-mount (only).

---

## **PTO Connection**

### **End Idler**

Optional - 6-3/16" diameter, lagged drive pulley with single shaft extension (one side); replaces standard 3-1/2" / 6" diameter idler pulley. Provides for sprocket/chain connection to adjoining upstream or downstream "driven" conveyor.

### **End Drive**

Optional - Series 600 and 800 drive pulley with double shaft extension (both sides); replaces standard pulley with single shaft extension. Provides for sprocket/chain connection to adjoining downstream "driven" conveyor.

### **Transfer Drive Kit - Direct Rotation**

Chain, connecting links, sprockets (RC-50), guards, etc., for connecting specified belt conveyor drive shaft component (End Idler or End Drive) to adjoining conveyor drive shaft with same rotation.

### **Transfer Drive Kit - Counter-rotation**

Chain, connecting links, sprockets (RC-50), idler wheels, guards, etc., for connecting specified belt conveyor drive shaft component (End Idler or End Drive) to specified adjoining conveyor with opposite drive shaft rotation (VBLR and BDLR).

### **Speed Ratios**

1.0:1

## Power Feeder Unit

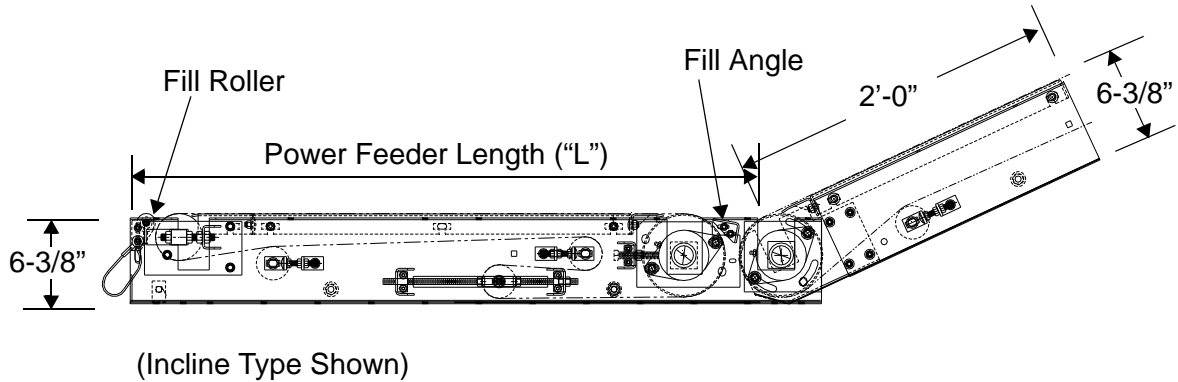

Figure C - 13 Power Feeder Unit

### Types

Incline - the top of the two pulleys is on a horizontal plane.

Decline - the top of the two pulleys is on a plane that is parallel to the decline bed.

Reversible - the top of the two pulleys is on a plane that is 1/2 the angle of the sloped bed.

### Frame/Bed

Type CF/Slider Bed; protective fill plates are mounted immediately adjacent to drive pulley(s) to minimize the gap between belt and pulley(s). Pivotaly adjustable - 10 to 25°.

### Length

3'-0" for 16", and 22" " W"

4'-0" for 16", 22", and 28" " W"

7'-0" for 34", and 40" " W"

### Belt and Lacing

Friction Surface (both sides), (PVK-90). Clipper No. 1A.

### Drive Pulleys

Two 6" diameter, lagged, edge crowned, drive pulleys PTO driven (RC-50 chain) from incline/decline conveyor.

### Take-Up Pulleys

G251AB - 2-1/2" diameter with 11/16" non-rotating hex shaft; internal, grease packed, precision (ABEC) ball bearings. Manual adjustment (8" maximum movement).

### End Idler Pulley

Standard - 3-1/2" diameter. Manual adjustment (1" movement) for belt tracking. See "End Idler Section - BCR and BCS", on page C - 4, for details.

Optional - 2-1/4" diameter (Knife-edge) edge crowned 3/4" diameter non-rotating CRS shaft and precision, grease packed, and sealed ball bearings. Manual adjustment (1" movement) for belt tracking.

### Snub Rollers

G251AB. See "End Idler Section - BCR and BCS", on page C - 4, for details.

### Fill Angle

Available for transition of short length items.

### Fill Roller(s)

G131P mounted in discharge end of the decline feeder unit. See "End Idler Section - BCR and BCS", on page C - 4, for details.

### Speed Ratios

Incline Only - Available sprocket ratios of 1.0:1, 1.09:1, 1.2:1, 1.35:1, and 1.5:1; larger sprocket on feeder; smaller on incline.

Decline Only - Available sprocket ratios of 1.0:1, 1.09:1, 1.2:1, 1.35:1, and 1.5:1; larger sprocket on incline; smaller on feeder.

Bidirectional - Ratio 1:1 only.

Power Feeder speeds are dependent on the ratios and speeds of the main incline/decline conveyor. See Table C 1.

Table C 1: Power Feeder Speed (FPM)

Main Conveyor Speed (FPM)	Chain Drive Ratio (X:1)				
	1.0:1	1.09:1	1.2:1	1.35:1	1.5:1
<b>For Descending Conveyors</b>					
30	30	33	36	41	45
45	45	49	54	61	68
60	60	65	72	81	90
75	75	82	90	101	113
90	90	98	108	122	135
120	120	131	144	162	180
150	150	164	180	203	225
180	180	196	216	243	270
200	200	218	240	270	300
250	250	273	300	338	375
300	300	327	360	405	450
350	350	382	420	473	525
<b>For Ascending Conveyors</b>					



Table C 1: Power Feeder Speed (FPM) (Continued)

Main Conveyor Speed (FPM)	Chain Drive Ratio (X:1)				
	1.0:1	1.09:1	1.2:1	1.35:1	1.5:1
30	30	28	25	22	20
45	45	41	38	33	30
60	60	55	50	44	40
75	75	69	63	56	50
90	90	83	75	67	60
120	120	110	100	89	80
150	150	138	125	111	100
180	180	165	150	133	120
200	200	183	167	148	133
250	250	229	208	185	167
300	300	275	250	222	200
350	350	321	292	259	233
400	400	367	333	296	267

## Non-Driven Jackknife Section

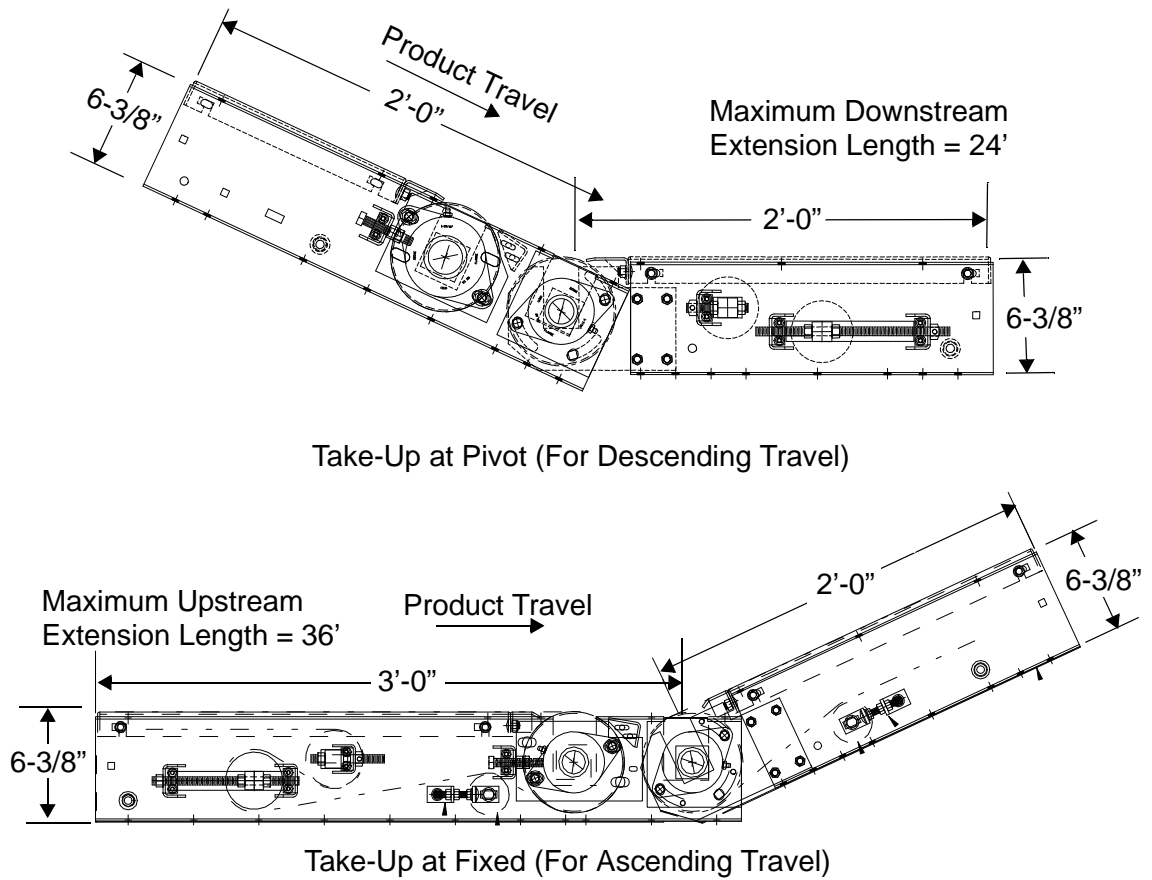

Figure C - 14 Non-Driven Jackknife

Same as Power Feeder Unit transfer drive components. Provides PTO drive connection to adjoining upstream/downstream conveyor. Adjustable from -10 to +25°.

## Auxiliary Take-Up Sections

### Manual - Auxiliary Take-Up

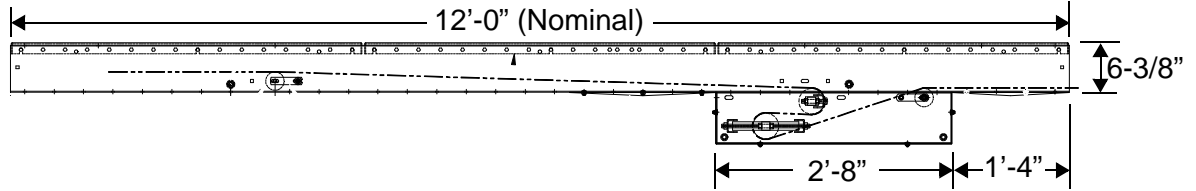

Figure C - 15 Manual - Auxiliary Take-Up

#### Frame

32" long x 7" deep x 10 ga. formed steel side plates with bolted cross-members. Mounts to bottom flanges of 12'-0" Intermediate Section (9'-0" optional).

#### Idler/Take-Up Pulley/shaft

Two 3-1/2" diameter; one edge crowned and one flat faced. Manual adjustment. See "End Idler Section - BCR and BCS", on page C - 4, for details.

#### Snub Rollers

Two G251AB - 2-1/2" diameter. See "End Idler Section - BCR and BCS", on page C - 4, for details.

### Spring - Auxiliary Take-Up

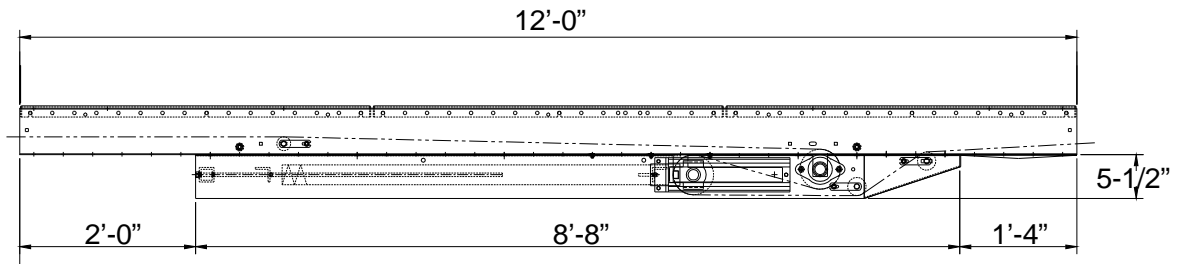

Figure C - 16 Spring - Auxiliary Take-Up

#### Frame

8'-8" x 6" deep x 10 ga. enclosure. Mounts to bottom flanges of 12'-0" Intermediate Section.

#### Idler/Take-Up Pulley/Shaft

Two 5-1/2" diameter pulleys (one edge crowned and one flat face) with welded 1-11/16" diameter turned, ground, and polished CRS shaft; no extensions; mounted in external take-up/flange mounted precision ball bearings (1-7/16" bore greased packed and re-lubricatable).

#### Snub Rollers

Two G251AB - 2-1/2" diameter, flat-faced. Adjustable for belt tracking. See "End Idler Section - BCR and BCS", on page C - 4, for details.

#### Take-Up

Tension springs (up to five depending on effective pull) with manual screw adjustment to make initial tension settings.

---

## Upper Bend Unit

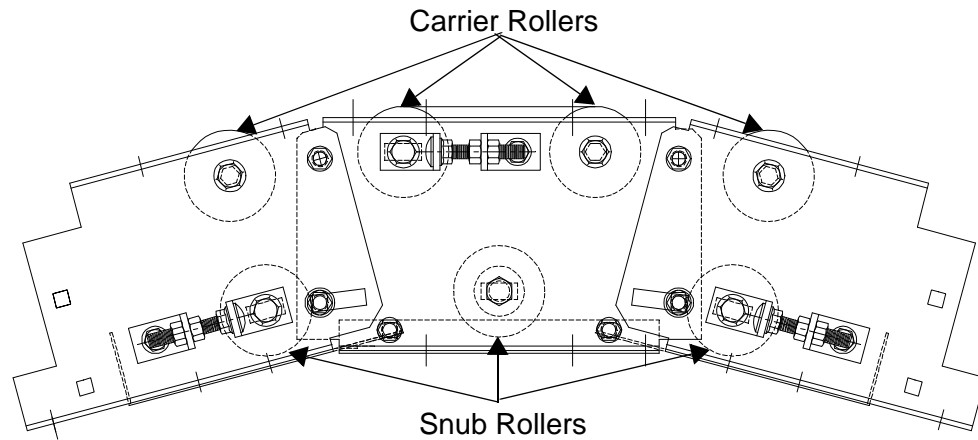

Figure C - 17 Upper Bend Unit

### Frame

Type CF, three formed steel side plates with bolted cross members. Adjustable from 10° to 25°.

### Carrier Rollers

Series 400 - Four G196A1 rollers; two end rollers adjustable for tracking.

Series 600 and 800 - Four G251B1 rollers; two center rollers adjustable for tracking.

SA2000 and SA2001 - Four G251AB rollers; two center rollers adjustable for tracking.

### Snub Rollers

Series 400 - Two G1961B rollers, adjustable for tracking.

Series 600 and 800 - Two G251AB rollers, adjustable for tracking.

SA2000 and SA2001 - Two G251AB rollers, adjustable for tracking. Three G251AB rollers when Effective Pull exceed 525 lbs.

---

## Belts and Lacings

Horizontal - PVC 100, Brushed Friction Surface X Friction Surface with No.1a Clipper Lacing.

Incline/Decline - PVC 100, Brushed Friction Surface X Traction Surface with No. 7 Clipper Lacing.

## Safety Guards

### Sheet Metal Guards

The following are supplied with 22 ga. sheet metal guards on their underside as standard equipment:

- Drive Units
- Idler Units
- Auxiliary Take-up Units
- Power Feeder Units
- Upper Bends
- Snub Rollers

Both ends of Intermediate Drives and Auxiliary Take-Up Units are guarded.

End guards are not provided for End Drives, End Idlers, and Power Feeder units (as standard). End guards are not needed when the components are installed in-line with adjoining conveyor(s). End guards for use with exposed conveyor ends are available and must be ordered separately.

Underside personnel guards for Intermediate Sections are not provided (as standard). The safety guards must be ordered separately for applications where the belt and return rollers are less than 8'-0" from the floor or are not considered "guarded by location."



## SECTION D:ENGINEERING DATA

Prepare a layout drawing for all horizontal or inclined belt applications. The drawing will identify the required equipment elements and will show clearance requirements for building structures, aisles, tie-ins with adjoining conveyors, equipment, etc. The drawing should be drawn to scale and must be accurate.

### Determining the Maximum Angle of Incline

The maximum angle at which items will convey depends upon:

- The length-to-height (L/H) ratio of the conveyed items.
- The weight distribution of the products within the containers.
- The available traction on the belt.

### L/H Ratio

To prevent tumbling, the length and height of an item should be such that a vertical line drawn downward from the center of the container would intersect the plane of the carrying surface within the middle third of the container's length. See Figure D - 1.

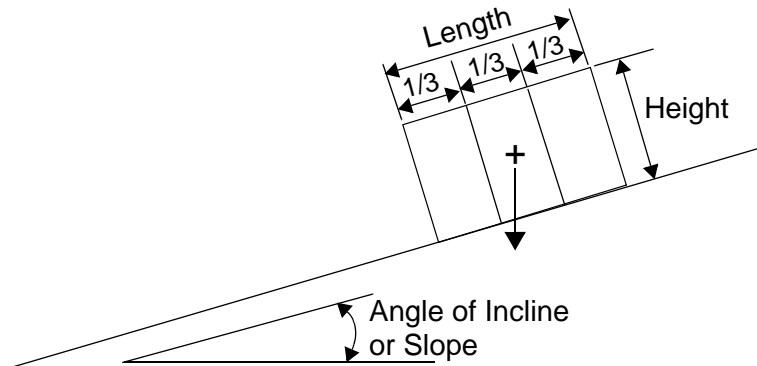

Figure D - 1 Angle of Incline

The maximum angle of incline may also be determined by using the formula below to find the product L/H ratio and by using Table D 1 to find the maximum degree allowable for a given ratio:

$$L/H = \text{Length of Product (L)} \div \text{Height of Product (H)}$$

Example: An inclined belt conveyor must convey a carton that is 18" long and 16" high. The (L/H) ratio is  $18 \div 16$  or 1.125. Therefore, from Table D 1, the maximum angle of incline must not exceed 21°. See Table D 1.

Table D 1: Maximum Incline

Angle	Max L/H	sin a	Angle	Max L/H	sin a	Angle	Max L/H	sin a	Angle	Max L/H	sin a
10°	.53	.179	14°	.75	.242	18°	.98	.309	22°	1.21	.375
11°	.58	.191	15°	.80	.253	19°	1.03	.325	23°	1.27	.391
12°	.64	.208	16°	.86	.276	20°	1.09	.342	24°	1.34	.407
13°	.69	.225	17°	.92	.298	21°	1.15	.358	25°	1.40	.427

---

## Weight Distribution

The angles in Table D 1 are based on the weight of the product being evenly distributed within the package or around the center of the package. If a package is top-heavy or its weight is concentrated to the front or the rear, the point from which the vertical line is dropped must be moved accordingly.

## Traction

The maximum angle of incline is also limited by the ability of the belt to properly convey packages without slippage. 25° is considered to be the maximum angle for conveying cartons when using the standard belting furnished on inclined conveyors. Plastic tote pans and other smooth bottomed items may be limited to lesser angles and may require special consideration when selecting the belt or angle of incline.



## Determining the Conveyor Length

An accurate conveyor layout drawing may be scaled to determine the lengths of the horizontal and inclined portions of the overall system.

For horizontal conveyors, the length is the overall measurement of the unit on the drawing.

For inclined conveyors, the overall conveyor length is the sum of the lengths of the parts, measured along the carrying surface of the unit. At points where the unit changes from inclined to horizontal, or vice versa, a single point should be established that is the end point of two measurements, one in each plane of travel. At the lower level, for instance, that point would be the intersection of the two planes of the carrying beds. At an upper bend, that point would be where extensions of the carrying beds would meet. It is important that the overall length of the unit be the sum of the measurements taken along the conveyor bed(s), with no gaps and no overlaps.

If an accurate conveyor layout drawing is not available, then dimensioned sketches such as that shown in Figure D - 2 can assist in the use of one of the indicated methods of calculation.

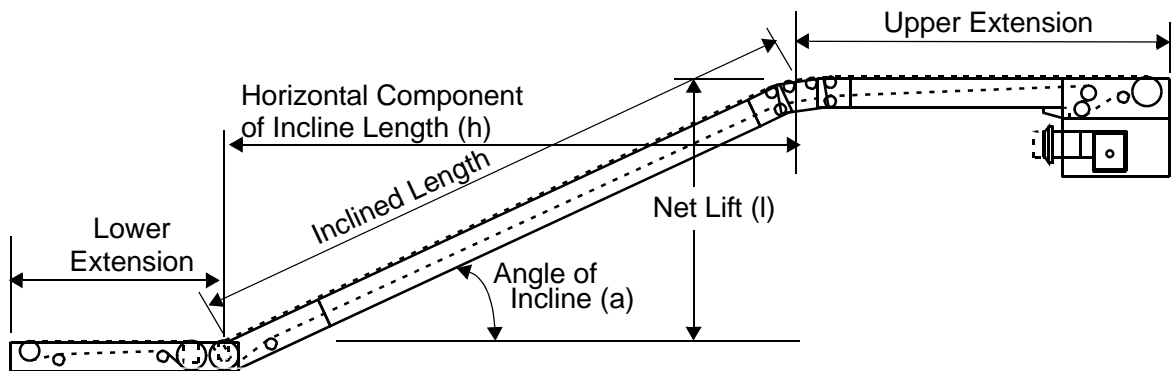

Figure D - 2 Proposed Conveyor Layout

For horizontal conveyors, the measured or calculated distance between the desired starting and destination points represents the overall length of the conveyor.

For inclined conveyors, the actual physical measurements of the site should be taken to supply as many of the dimensions and data as might be useful. When trying to determine the incline length, any two of the three related values must be known: angle of incline (a), net lift (l), or the horizontal component of the incline length (h). Usually the net lift is the first to be known. Note: the maximum angle of incline should not exceed 25°.

A sketch similar to the one in Figure D - 2 should be drawn and the known information placed on it.

If the angle of incline and net lift are known, use Table D 1 to determine the sin of angle a (written sin a), and apply the following formula to determine the inclined length:

$$\text{Incline Length} = \text{Net Lift} \div \sin a$$

If only the net lift and the horizontal projection of the incline are known, then:

$$\text{Incline Length} = \sqrt{(\text{Net Lift})^2 + (\text{Horizontal Length})^2}$$

Example: An inclined belt conveyor with a 4' power feeder is fed by a 3'-0" high upstream conveyor and is inclined at 21° to an upper level of 15'-0" above the lower floor. The upper level extension length is 6'-0". See Figure D - 3.

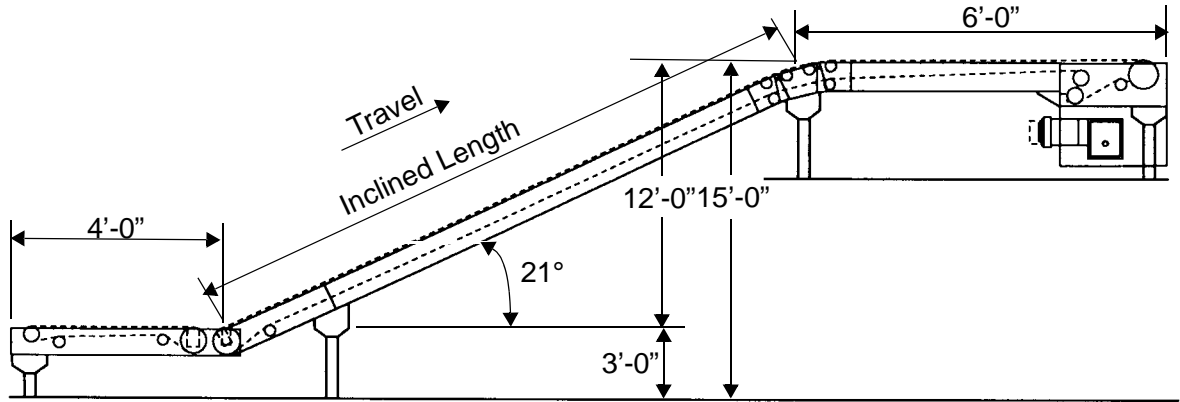

Figure D - 3 Calculation of Pertinent Values

Calculate as follows:

$$\text{Net Lift} = (15'-0") - (3'-0") = (12'-0")$$

$$\text{Inclined Length} = 12 \div .358 = 33.52' = 33'-6"$$

$$\text{Overall Length} = (4'-0") + (33'-6") + (6'-0") = 43'-6"$$

## Calculating Live Load

Use the appropriate formula to calculate the Live Load requirement for either a horizontal or inclined belt conveyor.

1. When WEIGHT and NUMBER of LOADS on a conveyor are known:

$$\text{Live Load (lbs./ft.)} = \frac{\text{Total Weight on Conveyor (lbs.)}}{\text{Conveyor Length (ft.)}}$$

Example: A Style 1, horizontal belt conveyor is 55'-0" long and has a total weight of 2200 pounds when fully loaded.

$$\text{Live Load (lbs./ft.)} = \frac{2200 \text{ lbs.}}{55 \text{ ft.}} = 40 \text{ lbs./ft.}$$

2. When load WEIGHTS and RATES are CONSTANT:

$$\text{Live Load (lbs./ft.)} = \frac{\text{Item Weight (lbs.)} \times \text{Rate (loads/min.)}}{\text{Conveyor Speed (fpm)}}$$

Example: A Style 3, inclined belt conveyor conveys 35 beverage cases per minute that weigh 25 pounds each. The conveyor's speed is 90 fpm.

$$\text{Live Load (lbs./ft.)} = \frac{25 \text{ lbs.} \times 35 \text{ cases/min.}}{90 \text{ fpm}} = 9.7 \text{ lbs./ft.}$$

3. When load WEIGHTS and RATES VARY:

$$\text{Live Load (lbs./ft.)} = \frac{\text{Max. Item Weight (lbs.)} \times \text{Max. Rate (loads/min.)}}{\text{Conveyor Speed (fpm)}}$$

Example: A Style 4, (descending) inclined belt conveyor conveys an assortment of cartons that weigh between 5 and 60 pounds each. The normal rate is 10 cartons per minute. The rate can increase to 40 cartons per minute. The conveyor's speed is 120 fpm.

$$\text{Live Load (lbs./ft.)} = \frac{60 \text{ lbs.} \times 40 \text{ cartons/min.}}{120 \text{ fpm}} = 20 \text{ lbs./ft.}$$

## Determining the Effective Belt Pull

### Horizontal Conveyors

Table D 2 contains values for the effective belt pull (per foot of conveyor length) for the standard Slider Bed. For Roller Beds with standard 9” centers, and optional 3” and 6” centers, use Table D 3.

The values in these Tables are based on bed type, width and live load. Multiply the appropriate value from the table by the length of the conveyor to find the Total Effective Pull (EPT) requirement.

$$\text{Effective Pull} = \text{Pull Value} \times \text{Conveyor Length}$$

The belt pull values for a Slider Bed (Table D 2) and a Roller Bed with 9” centers (Table D 3) are based on the standard belting furnished for horizontal and inclined belt conveyors.

The standard belting for Powered Belt Conveyors include:

- For horizontal conveyors - PVC-100 with “friction surface” top and bottom sides.
- For inclined conveyors - PVC-100 with a “friction surface” bottom side and a rough-surface on the top side.
- For power feeders - PVK-90 with a friction surface top side and a brushed bottom side.

Example: A Style 1 conveyor, 28” wide BCR (roller bed) with rollers on standard 9” centers is 55 feet long and carries a maximum load of 40 lb./ft. live load.

Per Table D 3, the pull for a 28” wide/9” centers BCR with 40 lb./ft. live load is 2.8 lb./ft.

$$EP = 2.8 \times 55 = 154 \text{ lb.}$$

Table D 2: Slider Bed - Belt Pull Values (lbs./ft.)

Live Load (lbs./ft.)	Conveyor Width - “W”				
	16”	22”	28”	34”	40”
<b>For BCS - Slider Bed and BCB Box Bed</b>					
0	0.3	0.4	0.5	0.6	0.8
5	2.0	2.1	2.2	2.3	2.5
10	3.7	3.8	3.9	4.0	4.2
15	5.4	5.5	5.6	5.7	5.9
20	7.1	7.2	7.3	7.4	7.6
25	8.7	8.9	9.0	9.1	9.3
30	10.4	10.6	10.7	10.8	11.0
40	13.8	14.0	14.1	14.2	14.3
50	17.2	17.4	17.5	17.6	17.7
60	20.6	20.8	20.9	21.0	21.1
80	27.4	27.6	27.7	27.8	27.9
100	34.2	34.3	34.5	34.6	34.7

Table D 3: Roller Bed - Belt Pull Values (lbs./ft.)

Live Load (lbs./ft.)	Conveyor Width - "W"				
	16"	22"	28"	34"	40"
<b>For BCR - Roller Bed - 3" Roller Center</b>					
0	0.5	0.7	0.9	1.1	1.3
5	0.8	1.0	1.2	1.4	1.6
10	1.1	1.3	1.5	1.7	1.9
15	1.4	1.6	1.8	2.0	2.2
20	1.7	1.9	2.1	2.3	2.5
25	2.0	2.2	2.4	2.6	2.8
30	2.3	2.5	2.7	2.9	3.1
40	2.9	3.1	3.3	3.5	3.7
50	3.6	3.7	3.9	4.1	4.3
60	4.2	4.3	4.5	4.7	4.9
80	5.4	5.6	5.7	5.9	6.1
100	6.6	6.8	7.0	7.1	7.3
<b>For BCR - Roller Bed - 6" Roller Center</b>					
0	0.3	0.4	0.5	0.6	0.8
5	0.6	0.7	0.8	1.0	1.1
10	0.9	1.0	1.1	1.3	1.4
15	1.2	1.3	1.4	1.6	1.7
20	1.5	1.6	1.7	1.9	2.0
25	1.8	1.9	2.1	2.2	2.3
30	2.1	2.2	2.4	2.5	2.6
40	2.7	2.8	3.0	3.1	3.2
50	3.3	3.5	3.6	3.7	3.8
60	3.9	4.1	4.2	4.3	4.4
80	5.2	5.3	5.4	5.5	5.6
100	6.4	6.5	6.6	6.7	6.8
<b>For BCR - Roller Bed - 9" Roller Center</b>					
0	0.3	0.3	0.4	0.5	0.6
5	0.5	0.8	0.7	0.8	0.9
10	0.8	0.9	1.0	1.1	1.2
15	1.1	1.2	1.3	1.4	1.5
20	1.4	1.5	1.6	1.7	1.8
25	1.8	1.8	1.9	2.0	2.1
30	2.1	2.1	2.2	2.3	2.4
40	2.7	2.8	2.8	2.9	3.0
50	3.3	3.4	3.4	3.5	3.6
60	3.9	4.0	4.1	4.1	4.2
80	5.1	5.2	5.3	5.4	5.4
100	6.3	6.4	6.5	6.6	6.7

## Ascending Conveyors

The effective pull calculations for the ascending conveyors consist of at least two (2) elements, and may include up to a maximum of four (4) elements. See Figure D - 4.

- EPa - the (optional) lower horizontal feeding element.
- EPb - the inclined element.
- EPc - the (optional) upper horizontal (runout) element.
- EPd - the elevation change (net lift) element.

The effective pull requirement of each element must be calculated and then added to that of the other elements to determine the conveyor's Total Effective Pull (EPT) requirement.

$$\text{EPT} = \text{EPa} + \text{EPb} + \text{EPc} + \text{EPd}$$

EPT is used as the basis for selecting the conveyor's drive series and determining the horsepower requirement for the power unit(s).

---

**Note:** The use of BCR (roller bed) sections for the inclined portion of the conveyor is recommended.

---

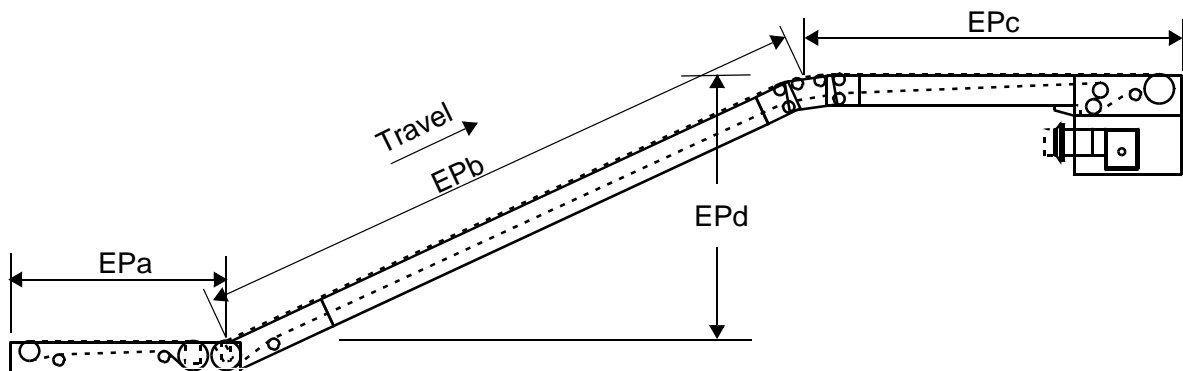

Figure D - 4 Ascending Belt Conveyor

$$\text{EPa} = \text{BCS Pull} * \times \text{Length (of lower horizontal feeding element)}.$$

$$\text{EPb} = \text{BCR Pull} * \times \text{Length (of inclined element)}.$$

$$\text{EPc} = \text{BCR/BCS Pull} * \times \text{Length (of upper horizontal runout element)}.$$

$$\text{EPd} = 1.15 \times \text{Live Load} \times \text{Net Lift}$$

\*Refer to Table D 2 and Table D 3.

---

Example: A Style 3 inclined belt conveyor, 22" wide with a 4'-0" power feeder, a 34'-6" inclined roller bed (with 9" roller centers), and a 6'-0" horizontal slider-bed runout. The live load is 10 lbs./ft. and the net lift is 12'-0".

Per Table D 2 and Table D 3, the pull(s) for 22" wide, BCS and BCR (9" roller centers) are:

$$\text{BCS} - 10 \text{ lbs./ft. live load} = 3.8 \text{ lbs./ft.}$$

$$\text{BCR} - 10 \text{ lbs./ft. live load} = 0.9 \text{ lbs./ft.}$$

$$\text{EPa} = 3.8 \times 4 = 15.2 \text{ lbs.}$$

$$\text{EPb} = 0.9 \times 34.5 = 31.1 \text{ lbs.}$$

$$\text{EPc} = 3.8 \times 6 = 22.8 \text{ lbs.}$$

$$\text{EPd} = 1.15 \times 10 \times 12 = \underline{138.0 \text{ lbs.}}$$

$$\text{EPT} = 207.1 \text{ lbs.}$$

Use 208 lbs. EPT as the basis for selecting the conveyor's drive series and determining the power unit's horsepower requirement.

## Descending Conveyors

The effective pull calculations for descending conveyors consist of the following basic elements:

- EP<sub>c</sub> - the (optional) upper horizontal feeding element.
- EP<sub>b</sub> - the declining element.
- EP<sub>a</sub> - the (optional) lower horizontal runout element.
- EP<sub>d</sub> - the elevation change (net lift) element.

The effective pull requirement of each element must be calculated separately and then added to that of the other elements to determine the conveyor's total effective pull requirement (EPT). See Figure D - 5.

$$EPT = EP_c + EP_b + EP_a + EP_d$$

Because the descending conveyor is lowering product, the calculated EP<sub>d</sub> is handled as a "negative" number, and subtracted from the sum of the other effective pulls. The negative net lift helps to power the belt.

EPT is used as the basis for selecting the conveyor's drive series and determining the horsepower requirement for the power unit(s).

---

Note: The use of BCS (slider bed) sections for the declined portion of the conveyor is recommended.

---

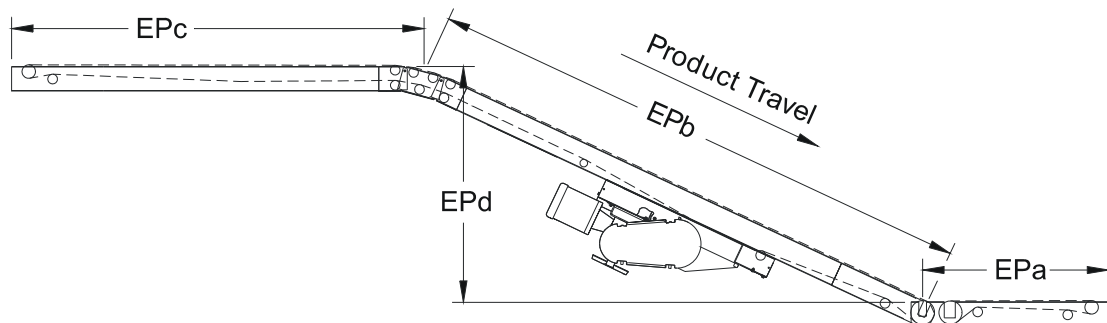

$$\text{Total Effective Pull} = EP_a + EP_b + EP_c - EP_d$$

8100FKI014a

Figure D - 5 Calculating EPT for Descending Conveyor

EP<sub>c</sub> = BCR/BCS Pull \* × Length (of upper horizontal feeding element).

EP<sub>b</sub> = BCS Pull \* × Length (of declining element).

EP<sub>a</sub> = BCR/BCS Pull \* × Length (of lower horizontal runout element).

EP<sub>d</sub> = 1.15 × Live Load × Net Lift

\*Refer to Table D 2 and Table D 3.

While ascending and descending conveyors consist of the same basic elements, the procedure for determining the conveyor's actual Total Effective Pull (EPT) differs.



Because of the many possible combinations of live load, bed-type(s), decline length, horizontal length(s), angles of incline, etc., a descending belt conveyor's EPT requirement must be calculated four times based on different operating conditions (modes). The first three modes deal with the loaded/empty condition of the inclined and horizontal elements. See Table D 4.

Table D 4: Operational Modes - Descending Belt Conveyor

Mode	EPa	EPb	EPc
1	Loaded	Empty	Loaded
2	Loaded	Loaded	Loaded
3	Empty	Loaded	Empty

Mode 4 represents the starting and stopping of the conveyor's "total moving weight". The power unit must have the capacity to handle this force.

$$EPT = .11 (\text{Total Live Load} + \text{Total Dead Load})$$

$$\text{Total Live Load} = \text{Live Load} \times \text{Overall Conveyor Length}$$

$$\text{Dead Load (DL)} = \text{See Table D 5}$$

$$\text{Total Dead Load} = (DLc + DLb + DLa)$$

$$DLc = \text{Dead Load} \times \text{Length (of upper feeder element)}$$

$$DLb = \text{Dead Load} \times \text{Length (of decline element)}$$

$$DLa = \text{Dead Load} \times \text{Length (of lower runout element)}$$

Table D 5: Descending Belt Conveyor Dead Load (DL) - lbs./ft.

Conveyor/Bed Type		Conveyor Width - "W"				
		16"	22"	28"	34"	40"
<b>Friction Surface Belt</b>						
<b>BCS</b>		1.3	1.9	2.4	3.0	3.6
<b>BCR</b>	9" C	3.4	4.8	6.2	7.6	9.0
	6" C	4.5	6.3	8.1	9.9	11.7
	3" C	7.8	10.8	13.8	16.8	19.8
<b>Rough Top Belt</b>						
<b>BCS</b>		2.2	3.3	4.4	5.4	6.4
<b>BCR</b>	9" C	4.4	6.3	8.2	10.0	11.9
	6" C	5.5	7.8	10.1	12.3	14.8
	3" C	8.7	12.2	15.7	19.2	22.8

Use the "highest" of the four (4) calculated EPT ratings as the basis for selecting the conveyor's drive series and determining the power unit's horsepower requirement.

Example: Use the same basic conveyor layout configuration as used for the ascending conveyor example, calculate for the four modes.

Per Table D 2 and Table D 3, the Pull(s) for 22" wide, BCS and BCR (9" roller centers) are:

BCR - 0 lbs./ft. Live Load = 0.3 lbs./ft.

10 lbs./ft. Live Load = 0.9 lbs./ft.

BCS - 0 lbs./ft. Live Load = 0.4 lbs./ft.

10 lbs./ft. Live Load = 3.8 lbs./ft.

Mode 1: Horizontal element(s) "loaded" and inclined element "empty":

$$EPT = (EPc + EPb + EPa + EPd) = 51.8 \text{ lbs.}$$

$$EPc = 3.8 \times 6 = 22.8 \text{ lbs.}$$

$$EPb = 0.4 \times 34.5 = 13.8 \text{ lbs.}$$

$$EPa = 3.8 \times 4 = 15.2 \text{ lbs.}$$

$$EPd = 1.15 \times 12 \times 0 = \underline{0 \text{ lbs.}}$$

$$EPT = 51.8 \text{ lbs.}$$

Mode 2: Horizontal element(s) "loaded" and inclined element "loaded":

$$EPT = (EPc + EPb + EPa + EPd) = 31.1 \text{ lbs.}$$

$$EPc = 3.8 \times 6 = 22.8 \text{ lbs.}$$

$$EPb = 3.8 \times 34.5 = 131.1 \text{ lbs.}$$

$$EPa = 3.8 \times 4 = 15.2 \text{ lbs.}$$

$$EPd = 1.15 \times (-12) \times 10 = \underline{-138.0 \text{ lbs.}}$$

$$EPT = 31.1 \text{ lbs.}$$

Mode 3: Horizontal elements "empty" and inclined element "loaded":

$$EPT = (EPc + EPb + EPa + EPd) = -2.9 \text{ lbs.}$$

$$EPc = 0.4 \times 6 = 2.4 \text{ lbs.}$$

$$EPb = 3.8 \times 34.5 = 131.1 \text{ lbs.}$$

$$EPa = 0.4 \times 4 = 1.6 \text{ lbs.}$$

$$EPd = 1.15 \times (-12) \times 10 = \underline{-138.0 \text{ lbs.}}$$

$$EPT = -2.9 \text{ lbs.}$$

Mode 4: EPT = .11 (total Live Load + Total Dead Load) = .11 (498 lbs.) = 53 lbs.:

Total Live Load = 10 lbs./ft. × 44.5 ft. = 445.0 lbs.

Dead Load (DL) = DL<sub>a</sub> = 1.9 lbs./ft. × 6.0 ft. = 11.4 lbs.

DL<sub>b</sub> = 6.3 lbs./ft. × 34.5 ft. = 217.5 lbs.

DL<sub>c</sub> = 3.3 lbs./ft. × 4.0 ft. = 13.2 lbs

= 687.1 lbs.

EPT = .11 (687 lbs.) = 76 lbs.

Use 76 lbs. as the basis for selecting the conveyor's drive series and determining the power unit's horsepower requirement.

### Additional Effective Pull for PTO

(If applicable) The Total Effective Pull of an adjoining conveyor must be ADDED to that of a belt conveyor when conveyors are connected via PTO unit.

Example: A Style 2 conveyor has an Effective Pull requirement of 171 lbs. and powers via PTO an "upstream" curve that has an EP requirement of 75 lbs.

Effective Pull = 171 + 75 = 246 lbs.

### Select the Drive Series

Based on the conveyor's Style and Effective Pull requirements, use Table D 6 to select the Drive Unit (series). A larger series unit may be used if desired.

Table D 6: Drive Unit Capacity - (EPT)

Conveyor	End Drives			Intermediate Drives	
	400	600	800	SA2000	SA2001
Styles 1 and 3	230 lbs.	473 lbs.	688 lbs.	-	-
Styles 2 and 4	-	-	-	900 lbs.	800 lbs.

Example: A Style 2 conveyor has an Effective Pull requirement of 246 lbs.

Table D 6 shows an SA2000 Intermediate Drive can be used for a Style 2 conveyor with 246 lbs. EPT.

The drive unit determined in this step is adequate for the defined application.

---

## Determining the Horsepower

Based on the conveyor's drive series and type, speed, and effective pull requirements, use Table D 7, Table D 8, or Table D 9 to determine the power unit horsepower requirement. Select the "lowest" horsepower with effective pull capacity that exceeds the conveyor's calculated requirement.

### Special Start-Up Condition

If the conveyor must:

- a) "start" when loaded with more than 70% of its calculated live load; and
  - b) the effective pull capacity of the selected horsepower in Table D 7 is highlighted,
- it is recommended that either an electrical "soft-start" unit be used with the power unit (preferred) or the selected "drive unit" be upgraded to the next higher series.

The actual capacities of these highlighted power units exceed the drive unit capacity by such a margin that a properly tensioned belt will probably slip on the drive pulley under this "loaded start-up" condition or cause other component damage.

Table D 7: Series 400, 600, and 800 End Drive Power Unit Capacity - (EP)

Speed fpm	Horsepower							
	1/2	3/4	1	1-1/2	2	3	5	7-1/2
<b>Series 400 Power Unit</b>								
30	<b>230</b>							
45	212	<b>230</b>						
60	176	230						
75	143	230						
90	121	206	<b>230</b>					
120	99	149	203	<b>230</b>				
150	82	123	164	230				
<b>Series 600 Power Unit</b>								
30	297	446	<b>473</b>					
45	216	348	464	<b>473</b>				
60	193	284	378	<b>473</b>				
75	156	249	332	473				
90	123	192	279	317	473			
120	101	151	207	317	428	<b>473</b>		
150	90	135	179	261	352	<b>473</b>		
180	70	106	141	214	292	449	<b>473</b>	
200	66	99	132	200	272	423	<b>473</b>	
250	52	78	104	158	215	334	<b>473</b>	
300	47	70	94	191	186	288	461	<b>473</b>
350	40	60	79	119	163	244	390	<b>473</b>
400	34	52	69	103	141	211	339	<b>473</b>
<b>Series 800 Power Unit</b>								
30	282	381	508	<b>688</b>				
45	226	359	451	652	<b>688</b>			
60	187	297	396	506	672	<b>688</b>		
75	152	242	322	472	627	<b>688</b>		
90	128	219	292	375	509	<b>688</b>		
120	105	158	216	332	416	593	<b>688</b>	
150	87	131	174	254	342	512	688	
180	74	111	148	224	305	437	688	
200	64	96	128	194	265	411	623	<b>688</b>
250	53	80	107	162	221	342	534	688
300	46	68	91	137	181	280	448	609
350	39	58	77	118	158	246	394	542
400	33	50	67	100	137	212	341	478

Table D 8: SA2000 Intermediate Drive Power Unit Capacity - (EP - lbs.)

Speed (rpm)	Reducer Mfg.	Drive Type	Horsepower							
			1/2	3/4	1	1-1/2	2	3	5	7-1/2
30	Grove	RC	361	553	728	900				
		TB	371	574	776	900				
	Reliance	RC	303	490	677	900				
		TB	324	514	678	900				
45	Grove	RC	241	369	485	749				
		TB	261	391	536	837				
	Reliance	RC	202	327	451	677				
		TB	229	362	483	748				
60	Grove	RC	193	293	391	603	816	900		
		TB	208	312	428	655	900			
	Reliance	RC	172	272	362	563	750			
		TB	182	273	399	612	816			
75	Grove	RC	154	235	313	482	653	900		
		TB	173	259	346	534	725	900		
	Reliance	RC	137	217	290	450	600			
		TB	161	242	336	503	671	900		
90	Grove	RC	144	215	287	432	587	900		
		TB	147	221	297	445	617	900		
	Reliance	RC	131	197	281	422	562	843		
		TB	137	205	273	437	577	900		
105	Grove	RC	123	185	246	370	503	763		
		TB	131	197	263	394	532	793	900	
	Reliance	RC	113	169	241	362	482	723		
		TB	124	185	247	382	517	742		
120	Grove	RC	110	166	221	334	452	674		
		TB	114	171	229	351	468	711	900	
	Reliance	RC	103	154	206	329	434	651		
		TB	108	162	216	334	446	679		
135	Grove	RC	98	147	196	297	402	599		
		TB	102	152	204	307	409	624	900	
	Reliance	RC	91	137	183	293	386	579		
		TB	96	144	192	297	396	604		
150	Grove	RC	91	137	183	274	368	599		
		TB	95	142	189	286	381	561	900	
	Reliance	RC	87	130	173	267	357	544		
		TB	91	136	182	273	371	543		

Table D 8: SA2000 Intermediate Drive Power Unit Capacity - (EP - lbs.) (Continued)

Speed (fpm)	Reducer Mfg.	Drive Type	Horsepower							
			1/2	3/4	1	1-1/2	2	3	5	7-1/2
165	Grove	RC	83	125	166	249	335	508		
		TB	86	129	172	260	346	510	900	
	Reliance	RC	79	118	157	243	324	494		
		TB	83	124	165	248	331	494		
180	Grove	RC	76	114	152	229	307	466		
		TB	79	118	158	239	319	480	789	900
	Reliance	RC	72	108	144	223	297	453		
		TB	76	114	152	227	303	470	783	
200	Grove	TB	72	108	144	217	289	433	731	900
	Reliance		70	104	139	209	278	423	705	
225	Grove	TB	64	96	128	193	257	385	644	900
	Reliance		62	93	124	186	248	378	626	
250	Grove	TB	58	86	115	173	231	347	585	900
	Reliance		56	84	111	167	223	341	564	
275	Grove	TB	53	79	106	158	211	317	530	805
	Reliance		52	78	104	157	203	310	513	
300	Grove	TB	48	73	97	145	195	292	469	738
	Reliance		48	72	96	144	191	287	470	
325	Grove	TB	45	67	89	134	179	270	433	681
	Reliance		44	66	88	132	177	265	449	
350	Grove	TB	41	62	83	124	166	251	402	627
	Reliance		41	62	82	123	164	246	417	
375	Grove	TB	39	58	77	116	155	234	375	583
	Reliance		38	57	77	115	153	230	398	
400	Grove	TB	36	54	73	109	145	219	352	554
	Reliance		36	54	72	108	144	215	365	
425	Grove	TB	34	51	68	102	138	206	331	522
	Reliance		34	51	68	101	135	203	342	
450	Grove	TB	32	48	64	97	129	195	313	493
	Reliance		32	48	64	96	128	191	323	
475	Grove	TB	31	46	61	92	122	185	296	467
	Reliance		30	45	60	91	121	181	306	
500	Grove	TB	29	44	58	87	116	176	293	422
	Reliance		29	43	57	86	115	172	291	

Note: RC = Roller Chain; TB = Timing Belt

Table D 9: SA2001 Intermediate Drive Power Unit Capacity - (EP - lbs.)

Speed (rpm)	Reducer Mfg.	Drive Type	Horsepower							
			1/2	3/4	1	1-1/2	2	3	5	7-1/2
30	Grove	RC	370	557	769					
		TB	371	574	728					
	Reliance	RC	324	513	715					
		TB	324	513	677					
45	Grove	RC	257	391	521	800				
		TB	261	391	536	800				
	Reliance	RC	229	362	483	750				
		TB	229	362	483	715				
60	Grove	RC	206	309	416	645	800			
		TB	216	324	432	668	800			
	Reliance	RC	183	274	398	616	800			
		TB	197	296	422	633	800			
75	Grove	RC	172	259	345	519	704	800		
		TB	177	267	356	539	730	800		
	Reliance	RC	158	237	338	507	675	800		
		TB	164	247	329	527	695	800		
90	Grove	RC	147	221	294	445	603	800		
		TB	152	230	307	460	609	800		
	Reliance	RC	137	206	274	439	579	800		
		TB	144	216	288	446	579	800		
105	Grove	RC	131	196	261	392	526	799		
		TB	131	196	263	394	532	800		
	Reliance	RC	124	185	247	382	509	777		
		TB	124	185	247	382	509	744		
120	Grove	RC	114	171	229	343	460	699		
		TB	144	171	230	345	460	702	800	
	Reliance	RC	108	162	216	334	446	680		
		TB	108	162	216	334	446	680		
135	Grove	RC	102	152	203	305	409	621		
		TB	105	158	212	317	423	624	800	
	Reliance	RC	96	144	192	297	396	604		
		TB	101	152	202	303	414	604		
150	Grove	RC	91	137	183	274	368	559		
		TB	95	142	189	286	381	576	800	
	Reliance	RC	87	130	173	267	357	544		
		TB	91	136	182	273	372	566	800	



Table D 9: SA2001 Intermediate Drive Power Unit Capacity - (EP - lbs.) (Continued)

Speed (fpm)	Reducer Mfg.	Drive Type	Horsepower							
			1/2	3/4	1	1-1/2	2	3	5	7-1/2
165	Grove	RC	83	125	166	249	335	508		
		TB	86	129	172	260	346	523	800	
	Reliance	RC	79	118	157	243	324	494		
		TB	83	124	165	248	331	508	800	
180	Grove	RC	79	118	158	237	316	476		
		TB	80	120	160	241	321	482	800	
	Reliance	RC	76	114	152	227	303	466		
		TB	77	116	155	232	309	473	800	
200	Grove	TB	72	108	144	217	289	436	731	800
	Reliance		70	104	139	209	278	426	620	
225	Grove	TB	64	96	128	192	257	385	650	800
	Reliance		62	93	124	186	247	379	592	
250	Grove	TB	58	86	115	173	231	347	585	800
	Reliance		56	84	111	167	223	341	568	
275	Grove	TB	53	79	106	158	211	319	512	800
	Reliance		52	78	104	157	209	315	513	
300	Grove	TB	48	73	97	145	193	292	469	739
	Reliance		48	72	96	144	191	289	482	
325	Grove	TB	45	67	89	134	179	270	433	682
	Reliance		44	66	88	133	177	265	405	
350	Grove	TB	41	62	83	124	166	251	402	633
	Reliance		41	62	82	123	164	246	413	
375	Grove	TB	39	58	77	116	155	234	375	591
	Reliance		38	57	77	115	153	230	385	
400	Grove	TB	36	54	73	109	145	219	352	554
	Reliance		36	54	72	108	144	215	361	
425	Grove	TB	34	51	68	102	137	206	331	522
	Reliance		34	51	68	101	135	203	340	
450	Grove	TB	32	48	64	97	129	195	313	493
	Reliance		32	48	64	96	128	191	321	
475	Grove	TB	31	46	61	92	122	185	296	467
	Reliance		30	45	60	91	121	181	304	
500	Grove	TB	29	44	58	87	116	175	281	443
	Reliance		29	43	57	86	115	172	262	

Note: RC = Roller Chain; TB = Timing Belt

## Determining Power Feeder Speed (fpm)

See Table D 10 for optional speed ratios for the descending and ascending conveyors

Table D 10: Power Feeder Speed (fpm)

Main Conveyor Speed (fpm)	Chain Drive Ratio				
	1.0:1	1.09:1	1.2:1	1.35:1	1.5:1
<b>For Descending Conveyors</b>					
30	30	33	36	41	45
45	45	49	54	61	68
60	60	65	72	81	90
75	75	82	90	101	113
90	90	98	108	122	135
120	120	131	144	162	180
150	150	164	180	203	225
180	180	196	216	243	270
200	200	218	240	270	300
250	250	273	300	338	375
300	300	327	360	405	450
350	350	382	420	473	525
<b>For Ascending Conveyors</b>					
30	30	28	25	22	20
45	45	41	38	33	30
60	60	55	50	44	40
75	75	69	63	56	50
90	90	83	75	67	60
120	120	110	100	89	80
150	150	138	125	111	100
180	180	165	150	133	120
200	200	183	167	148	133
250	250	229	208	185	167
300	300	275	250	222	200
350	350	321	292	259	233
400	400	367	333	296	267

## Effective Belt Pull Formula

### Roller Bed

$$\frac{F_r L(W_m + 2W_b + RC_t + RC_i) + (W_m)(h) + M_{AS} \times G}{F_t}$$

### Slider Bed

$$\frac{F_s L(W_m + W_b) + F_r L(W_b + RC_i) + (W_m)(h) + M_{AS} \times G}{F_t}$$

For declining conveyor, (h) is treated as a negative value. Resulting belt pull is treated as a positive pull value for component selection. Consideration must be given to the effects of starting, stopping, and varying load conditions.

Let  $\frac{V}{t} = 0$  unless used with frequent starts or with motors with service factor > 1.75.

Table D 11: Friction Factors

Type of Bed Surface	Friction Factor with Brushed Friction Surface (FS) Belting
Galvanized SB	.28
Bare Metal SB	.30
Powder Coated SB	.35

## Symbols

Table D 12: Symbols Table

Sym.	Meaning	Comment
$T_e$	Effective belt pull required to move the load.	
$V$	Conveyor speed. (feet per minute).	
$W_b$	Weight of belt = $.05 * [W-4]$ .	
$W_m$	Weight of conveyed material, (pounds per foot).	
$h$	Net change of elevation, (feet).	
$L$	Conveyor length, (feet) (meters).	
$R$	Unit weight of load-carrying roller less shaft, (pounds) (kilograms) = $W_R * (W-1)$ .	
$C_t$	Number of carrying rollers, (per foot).	
$C_i$	Number of return rollers, (per foot).	
$F_r$	Friction factor for roller bed = $.05$ .	
$F_s$	Friction factor slider bed supporting belt. See Table D 11.	
$F_t$	Terminal loss and contingencies factor	1 - Safety Factor + Bearing Loss 1 - $(.12 + .03) = .85$
$t$	Time for motor to reach full speed (seconds).	
$F_b$	Force due to belt wrap = approximately 2#/pulley with 180° wrap.	
$M_{AS}$	$(W_m + 2 * W_b + R_t C_t + R_i C_i) * L =$ (Total Live Load + Total Dead Load)	
$W$	Width of conveyor.	
$W_R$	Weight of roller (1.9" diameter x 16 ga.) = $.0981$ lbs./in. of width.	
$G$	Acceleration in G's = $\left[ \frac{V/60}{t} \right] \times \frac{1}{32.2}$	

**SECTION E: LAYOUT DIMENSIONS**

The section consists of dimensional drawings for Powered Belt Conveyor equipment.

**Intermediate Sections**

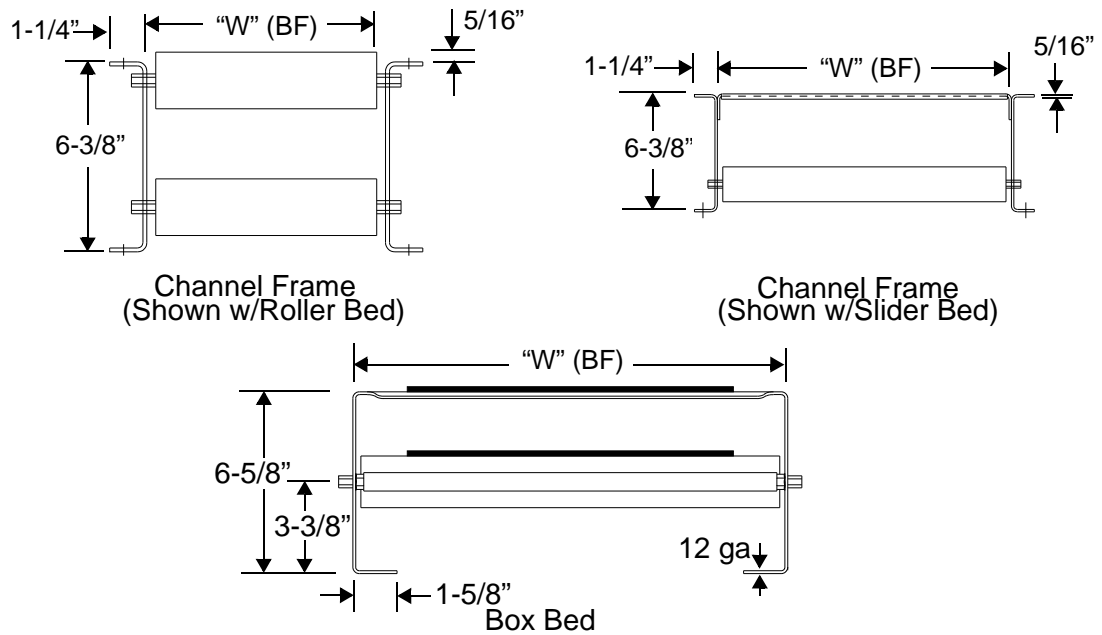
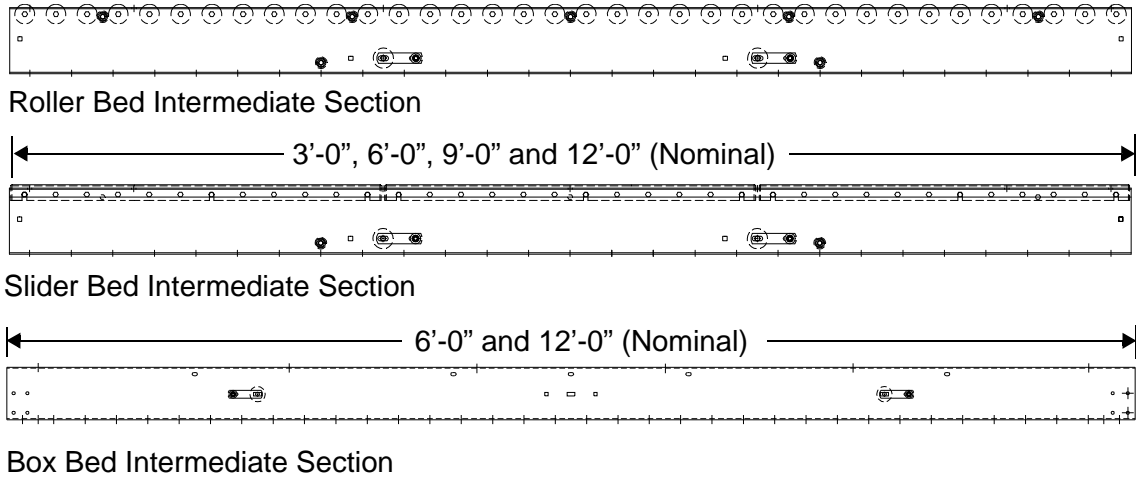
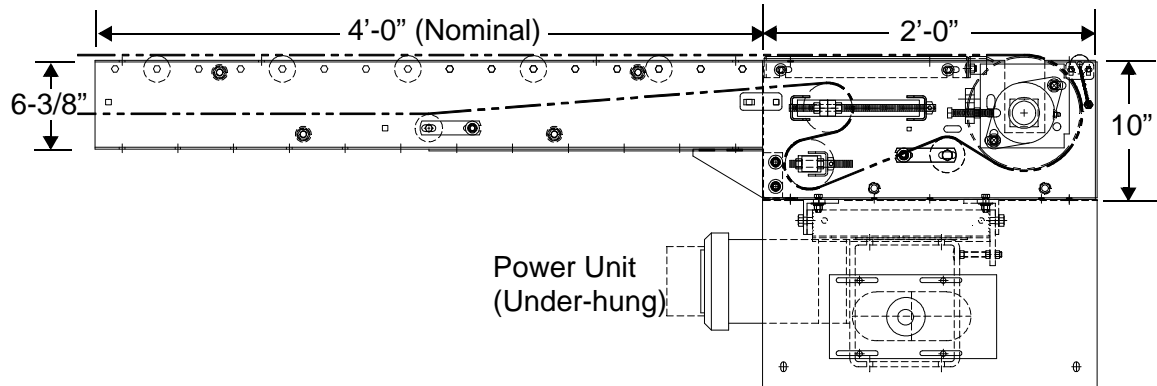

Figure E - 1 Intermediate Sections

## End Drive



(Typical for all - Series 800 Shown)

Figure E - 2 End Drive - Series 800

## End Idler

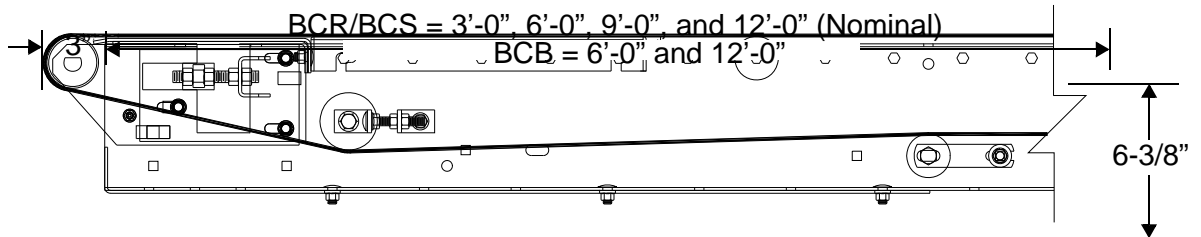

(3.5" and 6" Diameter Pulley Units also Available)

Figure E - 3 End Idler - Knife Edge Assembly (Shown)

Intermediate Drives

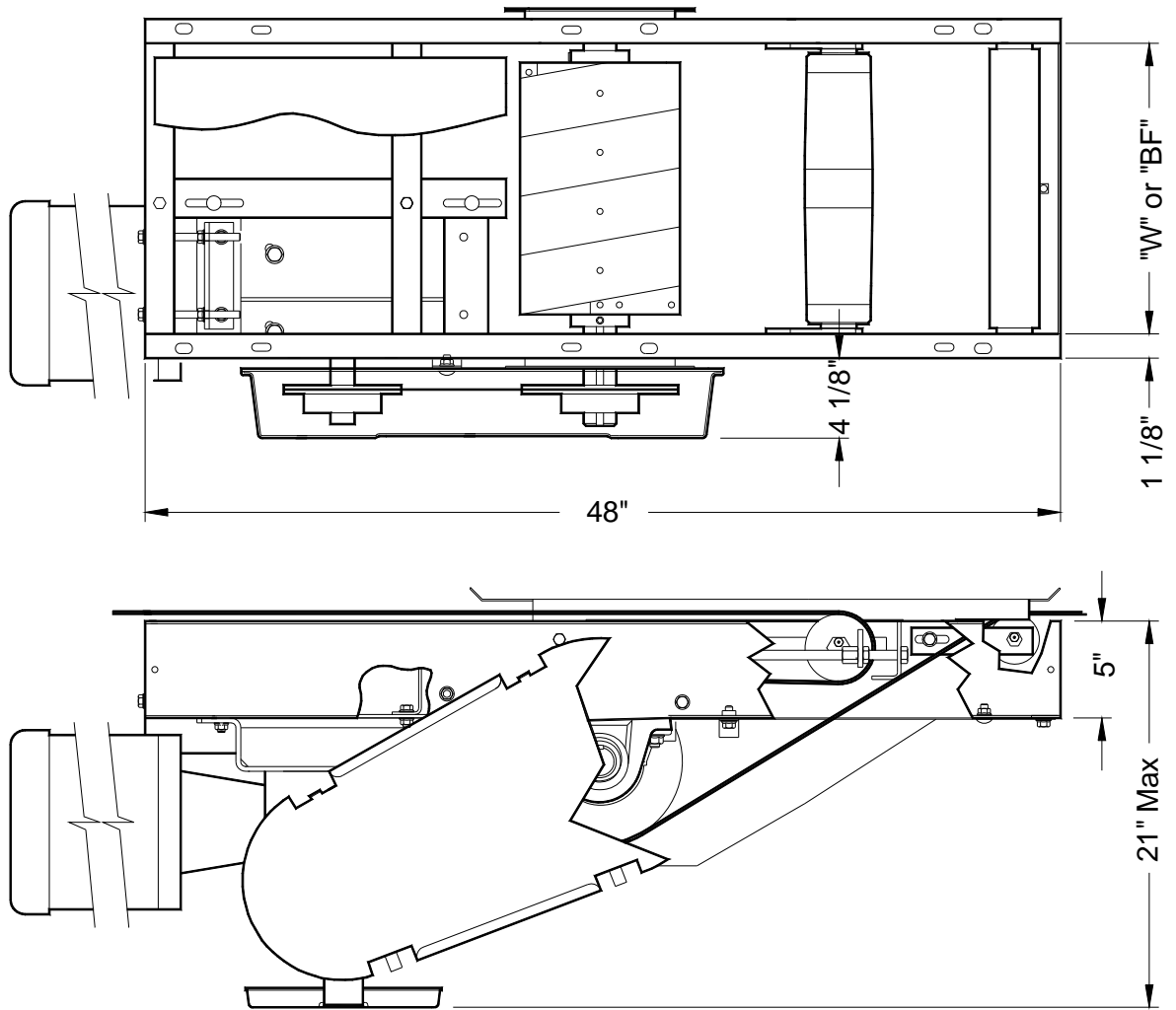

8100FK1007o

Figure E - 4 SA2000 - Intermediate Drive

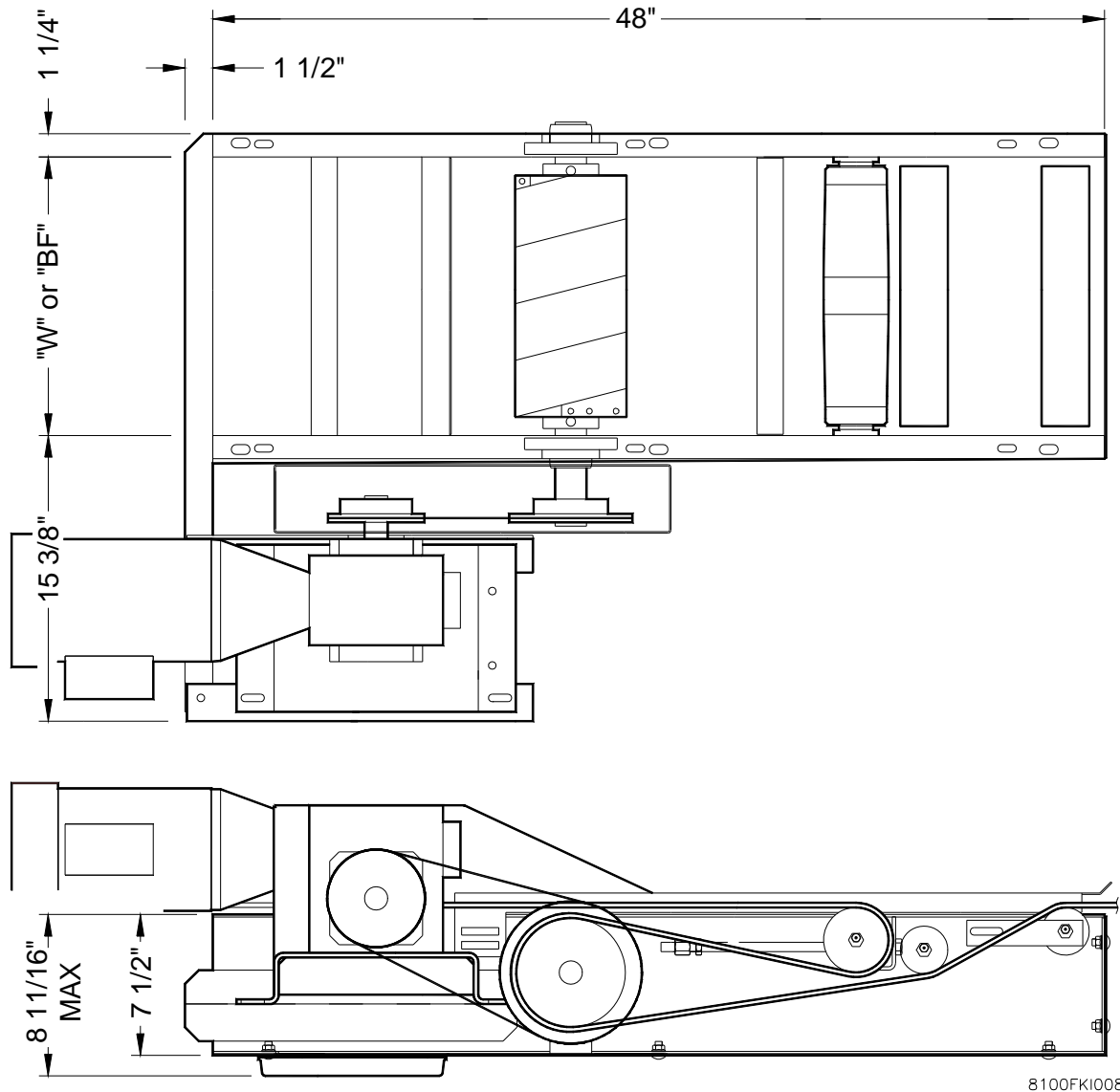

8100FKI008a

Figure E - 5 SA2001 - Intermediate Drive - Low Profile



## Auxiliary Take-Up Section

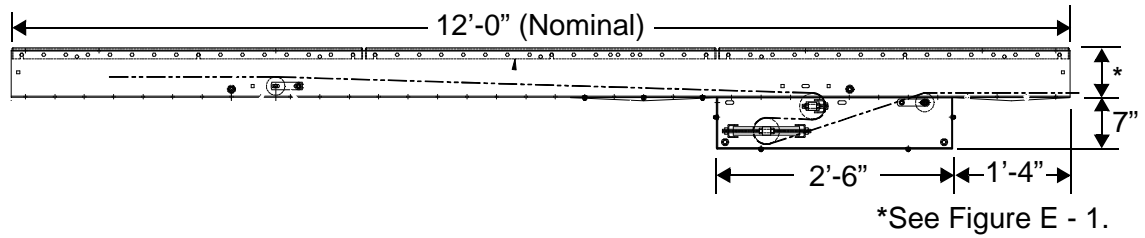

Figure E - 6 Auxiliary Take-Up Section - Series 400, 600, and 800 (3.5" Pulley(s))

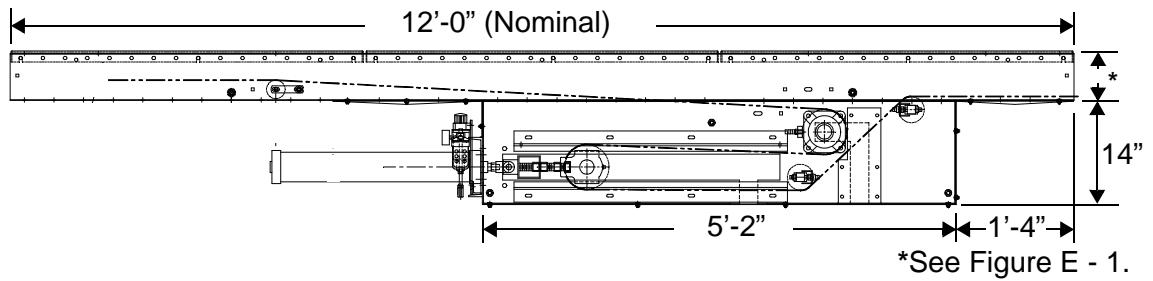

Figure E - 7 Auxiliary Take-Up Section - Automatic (Air) and Manual (6" Pulley(s))

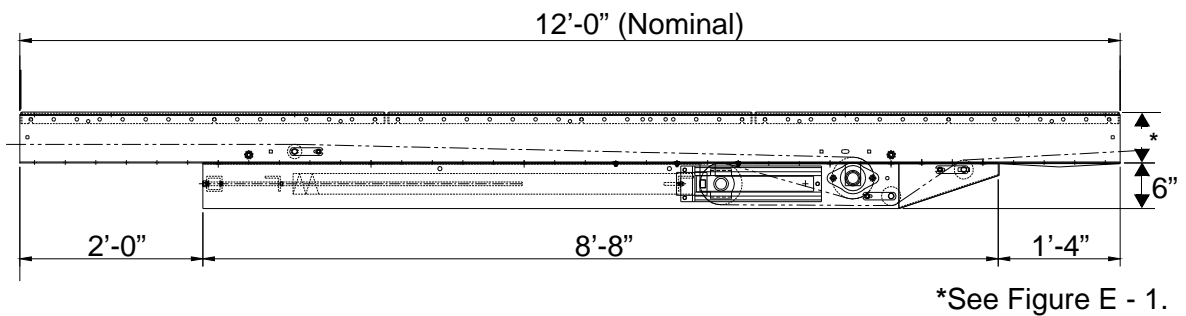
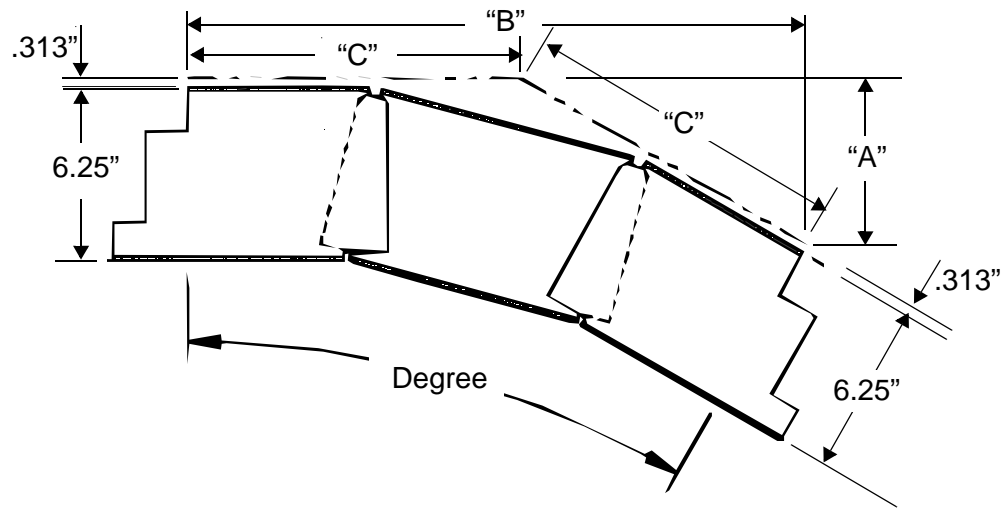

Figure E - 8 Spring Take-Up - Series 400, 600, and 800

## Upper Bend Section



Degree	"A"	"B"	"C"
10	2-1/16"	23-1/2"	11-13/16"
15	3-1/16"	23-7/16"	11-15/16"
20	4-1/8"	23-3/8"	12-1/16"
25	5-1/8"	23-1/8"	12-1/8"
30	6-1/8"	22-7/8"	12-1/4"

Figure E - 9 Upper Bend Unit

## Power Units

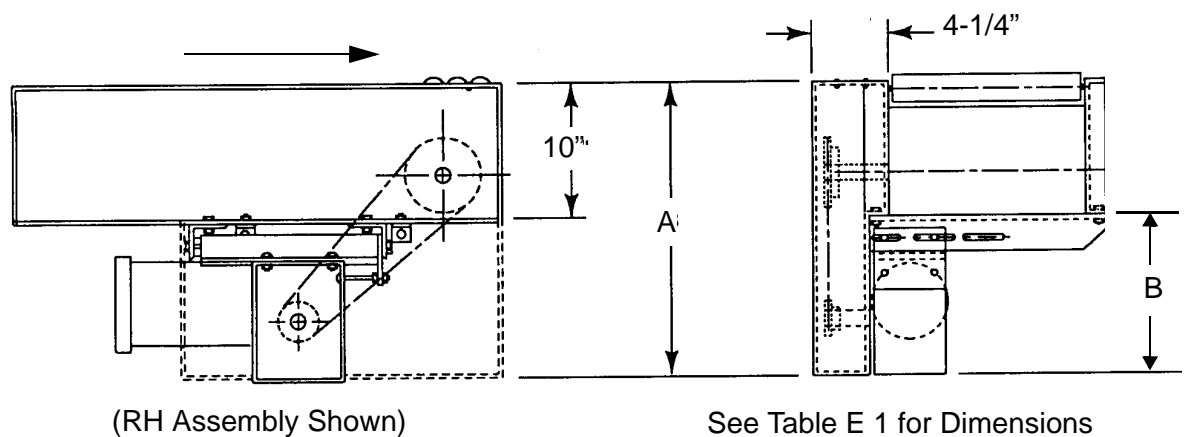

Figure E - 10 End Drive Power Unit - Under-hung Mount

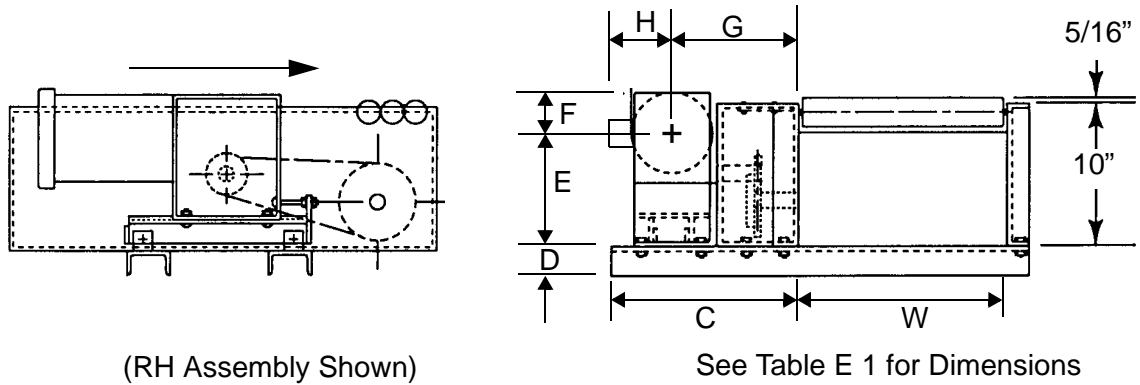
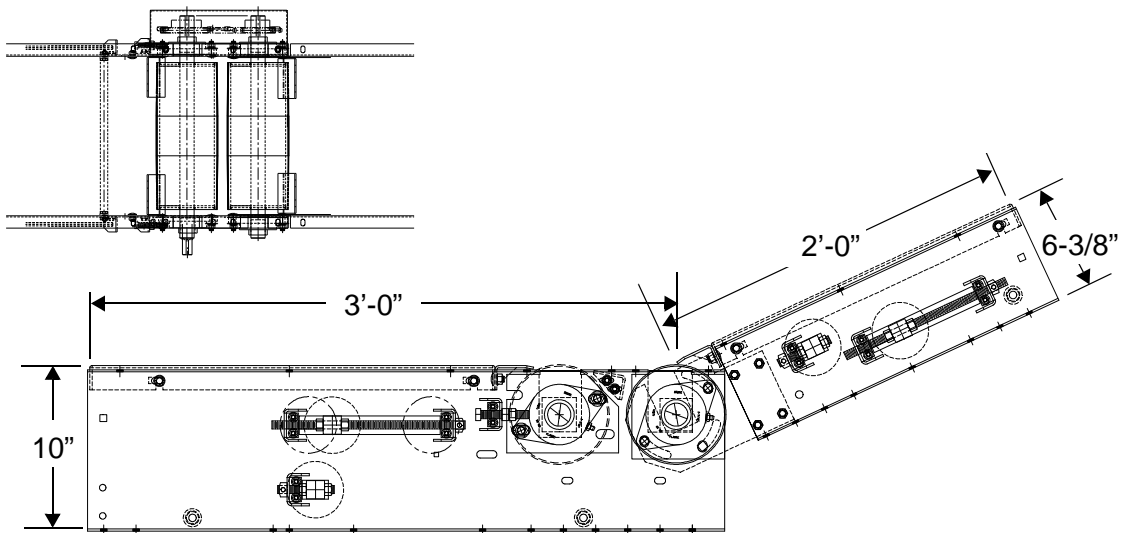

Figure E - 11 End Drive Power Unit - Side-Mounted

Table E 1: End Drive Power Unit Dimensions

Reducer No.									
Grove	Reliance	A	B	C	D	E	F	G	H
218	175	24.50"	10.88"	11.25"	1.44"	7.13"	3.69"	7.59"	6.00"
220	200	24.50"	11.38"	11.25"	1.44"	7.63"	3.69"	7.78"	6.00"
226	262	24.50"	12.06"	11.25"	1.44"	9.00"	4.81"	7.81"	7.06"
232	350	26.50"	15.80"	14.75"	1.44"	10.50"	4.81"	9.19"	7.06"

## Driven Jackknife



Note: Power Unit not shown (see Power Units)

Figure E - 12 Driven Jackknife

## Non-Driven Jackknife

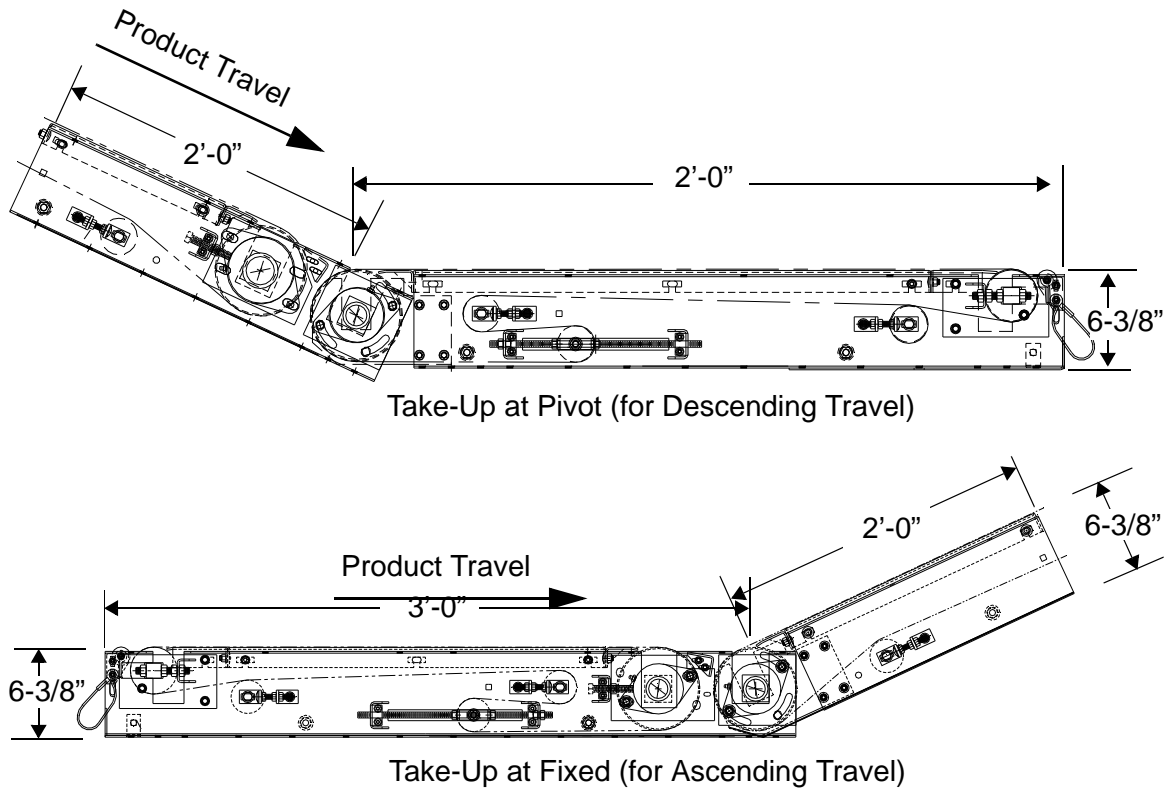
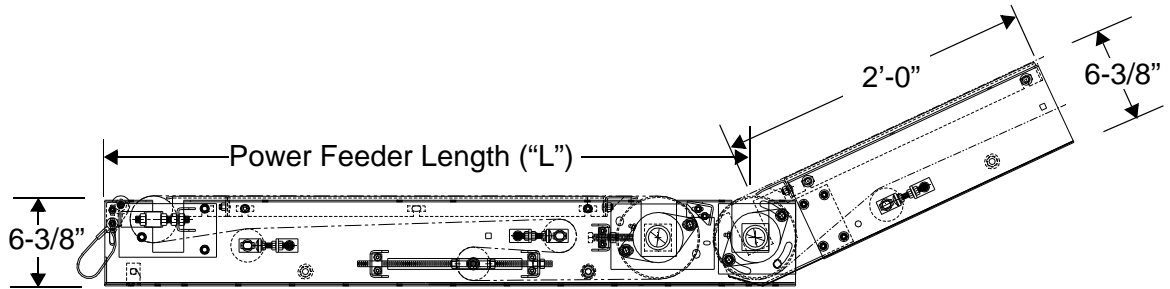

Figure E - 13 Non-Driven Jackknife - Take-Up at Fixed and Take-Up at Pivot

**Power Feeders**



Power Feeder Length "L"	Width "W" (BF)				
	16"	22"	28"	34"	40"
3'-0"	X	X			
4'-0"	X	X	X		
7'-0"				X	X

Figure E - 14 Power Feeder - Incline

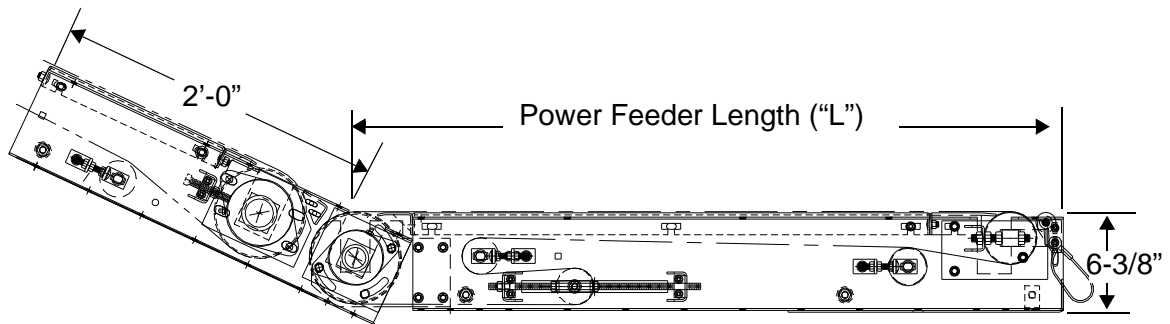

Figure E - 15 Power Feeder - Decline

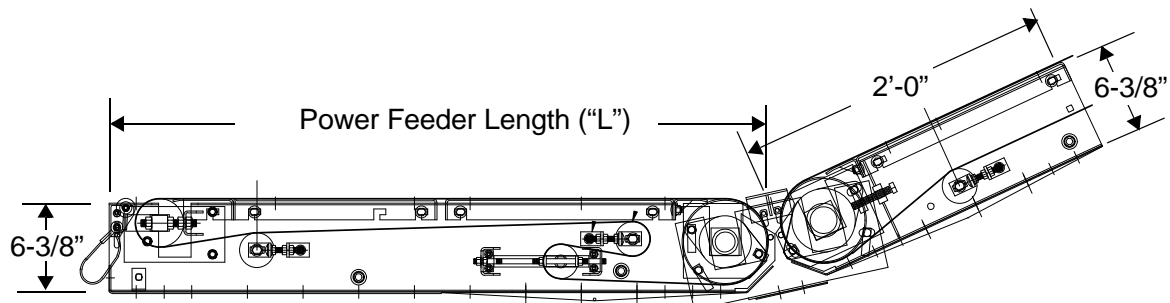

Figure E - 16 Power Feeder - Reversible



---

*SECTION F: ACCESSORIES***Powered Belt Conveyor Accessories**

Powered Belt Conveyor accessories include Floor Supports, Ceiling Hangers, Side Guides, and Case Deflectors. Refer to the following manuals for details:

- Floor Supports and Ceiling Hangers - Manual No. 5310
- Side Guides - Manual No. 5320
- Case Deflectors - Manual No. 5330





---

## **SECTION G:INSTALLATION PROCEDURES**

### **Accepting Shipment**

Immediately upon delivery, check that all equipment received agrees with the bill of lading or carrier's freight bill. Any shipping discrepancy or equipment damage should be clearly noted on the freight bill before signing.

### **Shortages or Errors**

Report any shortages or errors to the Manufacturer's Customer Service in writing within ten days after receipt of shipment.

### **Lost or Damaged Shipment**

Report lost shipments to the Manufacturer's Shipping Department.

If shipping damage is evident upon receipt of the conveyor equipment, note the extent of the damage on the freight bill and immediately contact the transportation carrier to request an inspection. Do not destroy the equipment crating and packing materials until the carrier's agent has examined them. Unless otherwise agreed by the manufacturer, the Purchaser (User) shall be responsible for filing claims with the transportation carrier. A copy of the inspection report along with a copy of the freight bill should be sent to the Manufacturer's traffic department.

### **Claims and Returns**

All equipment furnished in accordance with the Manufacturer's Agreement is not returnable for any reason except where authorized in writing by the Manufacturer. Notification of return must be made to the Manufacturer's Customer Service Department, and if approved, a "Return Authorization Tag" will be sent to the Purchaser (Users). The return tag sealed in the "Return Authorization Envelope" should be securely affixed to the exterior surface on any side of the shipping carton (not top or bottom), or affixed to any smooth flat surface on the equipment, if not boxed.

Send authorized return shipment(s) transportation charges prepaid to the address indicated on the Return Authorization Tag. If initial shipment is refused, the Purchaser (User) shall be liable for all freight charges, extra cost of handling, and other incidental expenses.

### **Codes and Standards**

The conveyor equipment is designed and manufactured to comply with the American National Standard Institute's "Safety Standards for Conveyors and Related Equipment" (ANSI B20.1) and with the National Electrical Code (ANSI/NFPA70).

The Purchaser/Operator shall be familiar with, and responsible for, compliance with all codes and regulations having jurisdiction regarding the installation, use, and maintenance of this equipment. Appropriate lockout/tagout policy and procedures shall comply with the minimum safety requirements outlined in the American National Standard Institute's current publication (ANSI Z244.1).

---

## Warning Signs

Warning signs and labels posted on or near the conveyor equipment shall not be removed, painted over, or altered at any time. All safety devices, warning lights, and alarms associated with the conveyor system should be regularly tested for proper operation and serviced as needed. If the original safety item(s) become defective or damaged, refer to the conveyor parts list(s) of bill(s)-of-materials for replacement part numbers.

## Safety Precautions

- DO turn off conveyor power source(s) and affix appropriate lockout/tagout device(s) to operating controls before servicing the equipment. ONLY trained and qualified personnel who are aware of the safety hazards should perform equipment adjustments or required maintenance while the conveyor is in operation.
- DO observe all warning signs, lights, and alarms associated with the conveyor operation and maintenance, and be alert at all times to automatic operation(s) of adjacent equipment.
- DO use extreme caution near moving conveyor parts to avoid the hazard of hands, hair, and clothing being caught.
- DO NOT sit on, stand on, walk, ride, or cross (over or under) the conveyor at any time except where suitable catwalks, gates, or bridges are provided for personnel travel.
- DO NOT attempt to repair any equipment while the conveyor is running, replace any conveyor component without appropriate replacement parts, or modify the conveyor system without prior approval by the manufacturer.
- DO NOT operate the conveyor until all safety guards are securely in place, all tools and non-product materials are removed from or near the conveying surfaces, and all personnel are in safe positions.
- DO NOT remove or modify any safety devices provided on or with the conveyor.
- DO NOT clear jams or reach into any unit before first turning off the equipment power source(s) and affixing appropriate lockout/tagout device(s).

## Parts Replacement

To minimize production downtime, selected conveyor spare parts should be stocked for replacement of defective components when required. Refer to the equipment bill(s)-of-materials where quantity requirements or code numbers are not indicated on the conveyor parts list. For added convenience, a list of selected spare parts for standard products is included in this manual (see Section I).

## Factory Assistance

Contact Field Service for installation, operation, or maintenance assistance, or Customer One Protection (COP) for replacement parts.

## Pre-Installation Set-up

Prior to installation, review the layout drawings to determine the proper location, orientation, and elevation of the conveyor sections. Read all instructions provided in this manual.

Review the plan drawings to identify the individual components that make up the conveyor unit and note the orientation, right-hand or left-hand, of the appropriate components and drives. Motor driven components (see Figures G - 1 through G - 4) have their orientation

shown on the plan of the conveyor by a box depicting a chain guard on one side of the conveyor.

Snap a chalk line on the floor or other support base to establish the centerline of the conveyor. Arrange the conveyor items and mounting supports along this base line according to the layout drawing to ensure that all components are present and are compatible for proper assembly. Leave field-installed rollers, photoelectric controls, and other accessory items in the shipping containers until all conveyor items are completely assembled, mounted on supports, and adjusted for proper elevation.

End drives are for one-way travel and must be assembled at the discharge end of the conveyor. One-way Intermediate Drives should be assembled as close as possible to the discharge end of the conveyor. Intermediate Drives for reversing operation should be located near the middle of the conveyor.

## **Style Identification**

Combinations of the equipment elements are varied. Figures G - 1 through G - 4 illustrate the conveyor styles that are available.

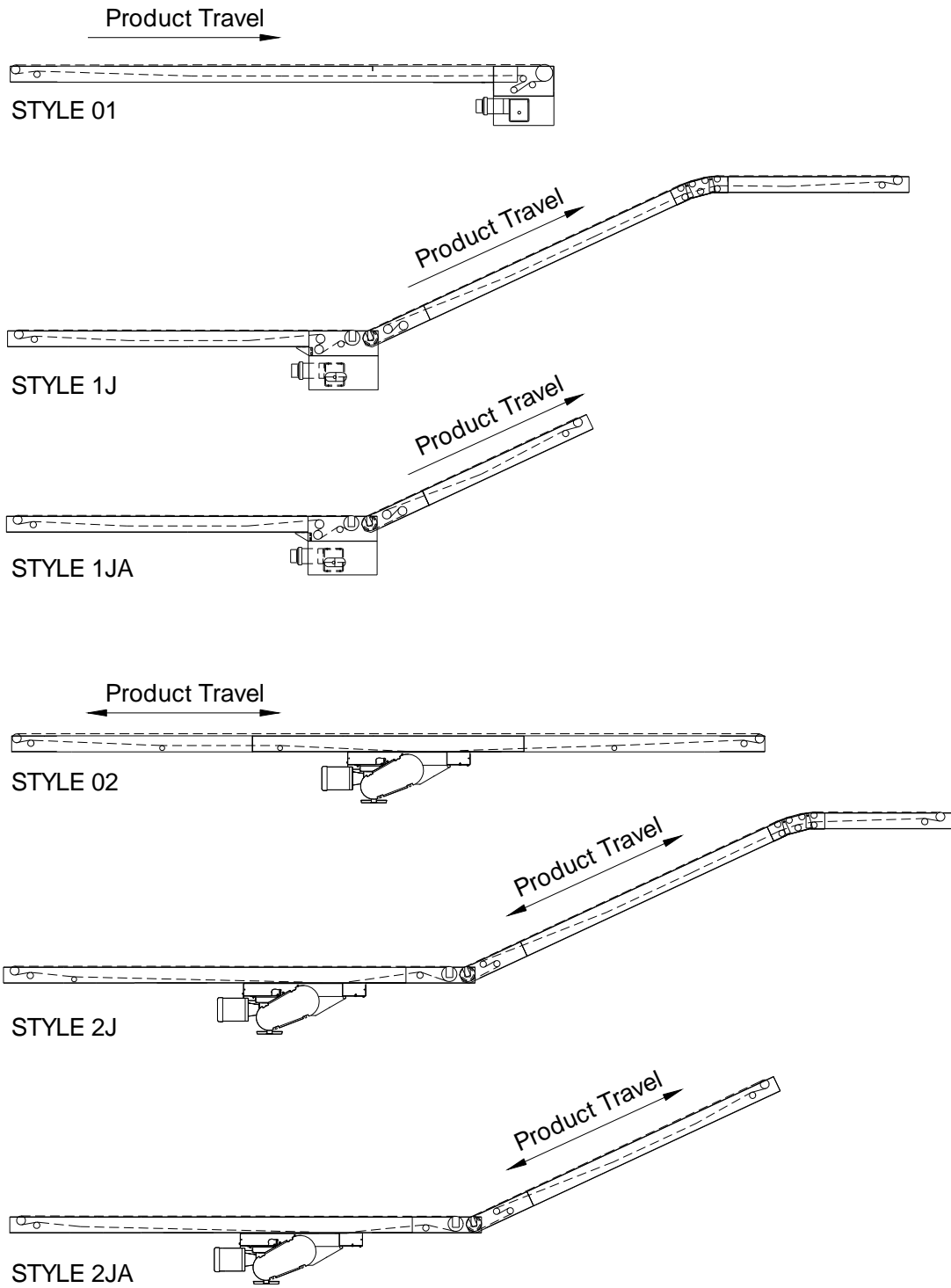

BUSFKI015A

Figure G - 1 Powered Belt Conveyor Style Identification - Sheet 1 of 4

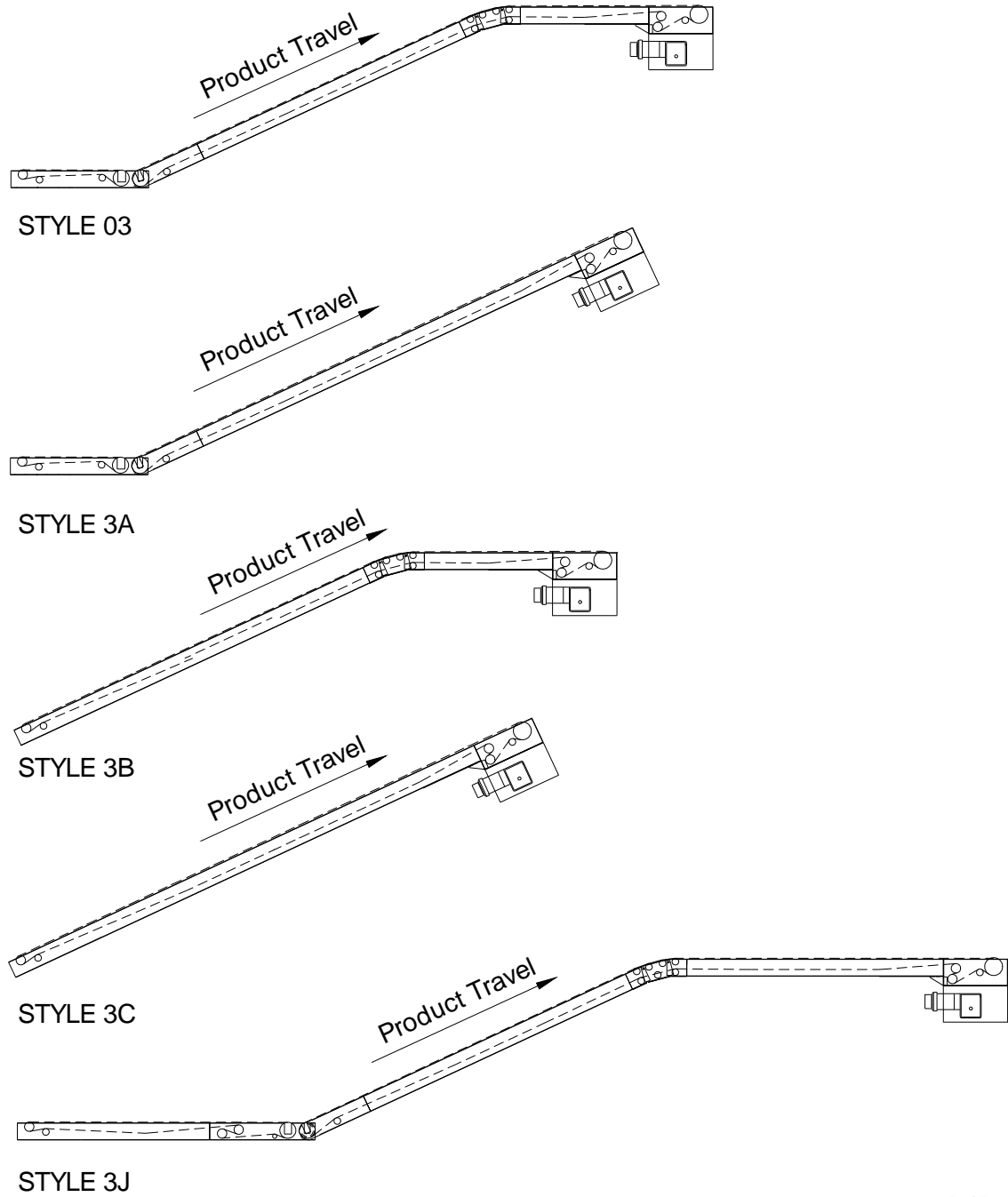

BUSFKI016A

Figure G - 2 Powered Belt Conveyor Style Identification - Sheet 2 of 4

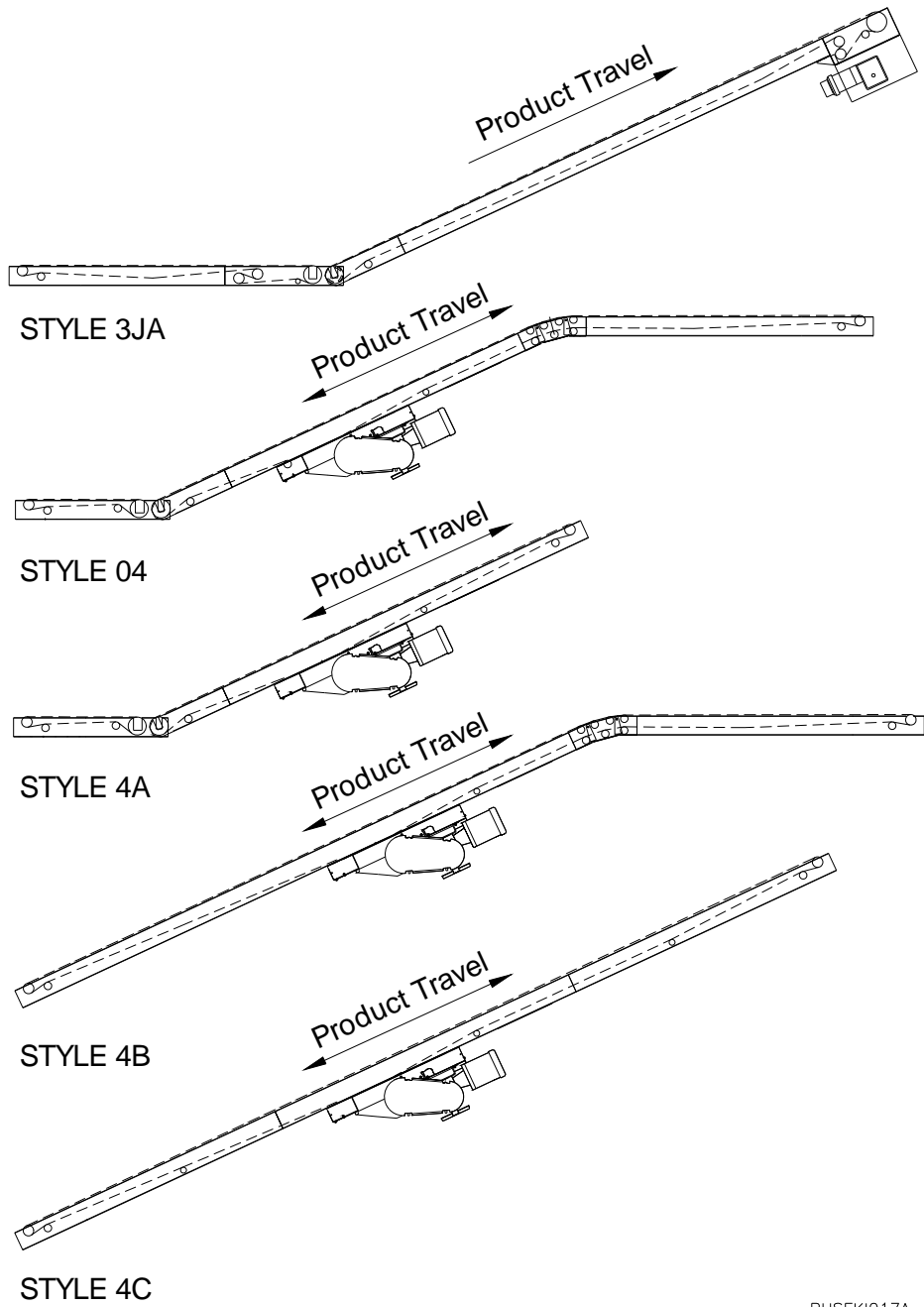

BUSFKI017A

Figure G - 3 Powered Belt Conveyor Style Identification - Sheet 3 of 4

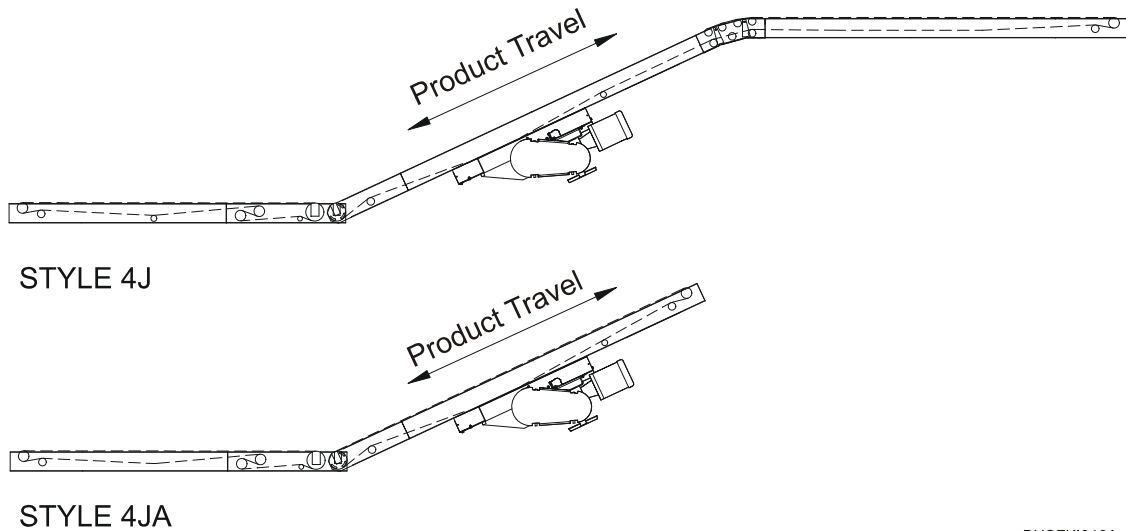

BUSFKI018A

Figure G - 4 Powered Belt Conveyor Style Identification - Sheet 4 of 4

## Assembling the Bed Section

Use the following steps to assemble the conveyor:

1. Remove any shipping braces and filler blocks and check the alignment of frames, pulleys, and rollers of each section before proceeding. Corner-to-corner diagonal frame measurements of each conveyor section should be equal within 1/16". Also, check that all idler rollers and pulleys rotate freely.
2. Starting at one end of the conveyor, attach two supports to the first section. Fasten it in place. See Figure G - 5 and Figure G - 6.

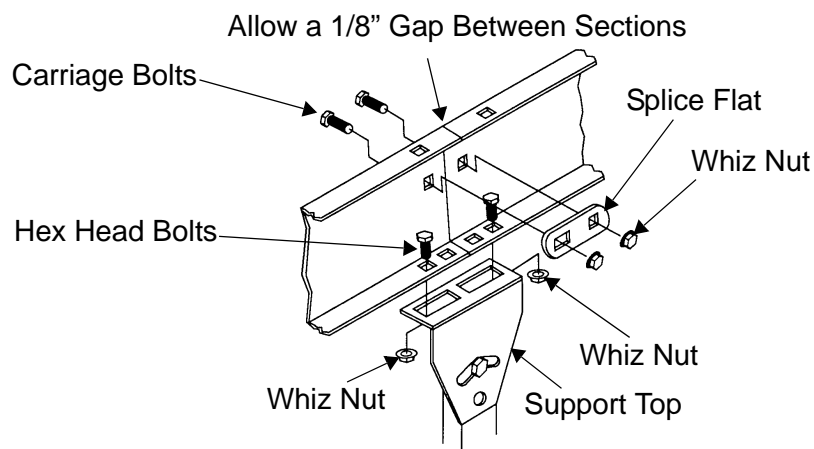

Figure G - 5 Standard Floor Support Assembly

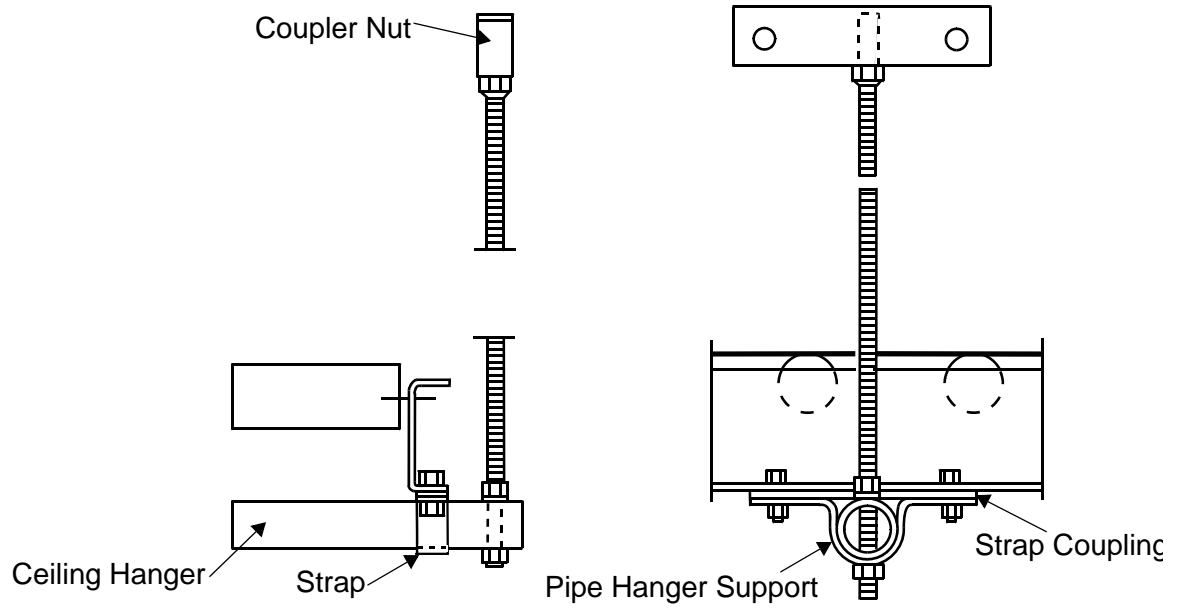

Figure G - 6 Ceiling Hanger Installation



3. Adjust the supports to the required height and level the conveyor section using a spirit level. Check the alignment of the frame, pulleys, and rollers.

**Note:** Frames, pulleys, and rollers **MUST** be square to properly track the belt. When the corner-to-corner squaring method is impractical, as with long narrow sections, use a steel square to check (and realign if necessary) pulleys, rollers, and bolted cross members to ensure they are mounted perpendicular to the conveyor side frames.

4. If not otherwise noted, return rollers should be mounted according to the following:
  - each 3'-0" and each 6'-0" long section has one return roller.
  - each 9'-0" and each 12'-0" long section has two return rollers, with the maximum distance between adjacent rollers not to exceed 6'-0".
5. Repeat steps 1 through 3 for the remainder of the conveyor sections. Position, align, level, square, and couple each conveyor section before moving to the next section.

If a splice is located directly over a support, the support and coupling strap securely couple the two sections together. If the splice is located somewhere other than over a support, a splice plate must be used. See Figure G - 7.

The maximum allowable center-to-center distance between supports is 12'-0".

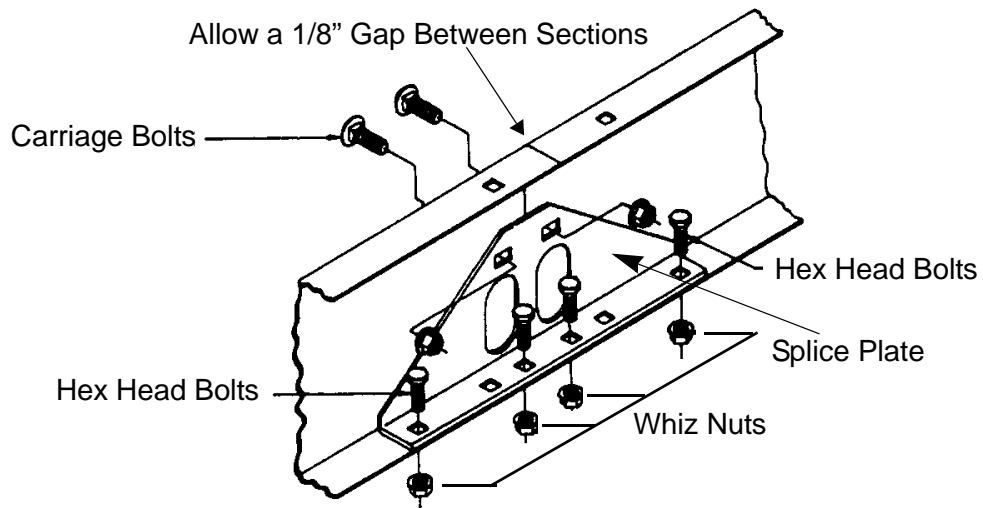

Figure G - 7 Splice Plate Assembly

## Power Unit Assembly

The Power Unit is shipped from the factory fully assembled to the drive section. When installing, check the following before starting.

### Lubricant

Check that the reducer lubricant is up to the “Oil Level Plug.” Before adding any lubricant, refer to the manufacturer’s tags attached to the reducer.

### Reducer Plugs/Fittings

Check that the oil level and drain plugs are properly installed and sufficiently tightened.

### Sprocket Alignment

**CAUTION:** Before working on a Power Unit or PTO unit, make certain the conveyor’s power disconnect is locked in the open position and tagged to prevent accidental or unexpected application of power.

Check alignment of chain and timing belt sprockets. See Figure G - 8.

Shafts (pulley and reducer) must be parallel.

For timing belt sprockets, misalignment should not exceed 1/4° (1/16” per foot of center distance).

See “Pre-Start-Up Preparation”, on page G - 17, for additional information.

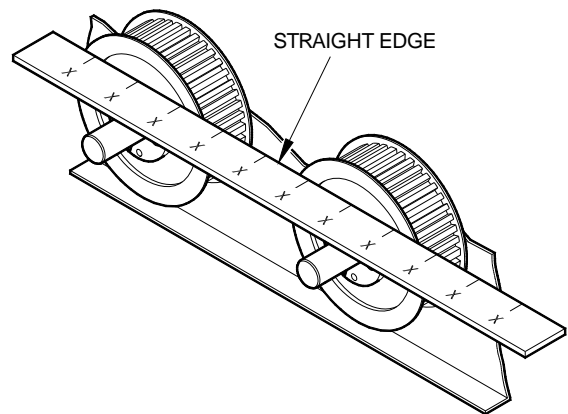

Figure G - 8 Checking Sprocket Alignment

8140TBC020a

### Set Screw Tightening Procedure (Type B Sprockets)

Check that set screws are tight. See Figure G - 9.

Use the following steps to tighten the set screws:

1. “Snug-up” both set screws.
2. Tighten (in sequence) “A” 25%, “B” 50%, “A” 75%, “B” 100%, and finally “A” 100% of recommended torque rating. See Table G 1 for recommended torque ratings.

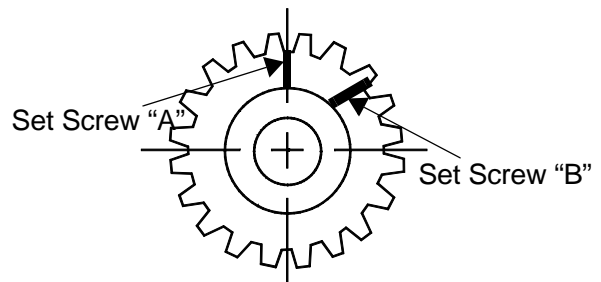

Figure G - 9 Type B Sprocket/Hub

Table G 1: Recommended Set Screw Torque

1/4”-20	5/16”-18	3/8”-16
70 inch-lbs.	130 inch-lbs.	230 inch-lbs.

## Installing the Upper Bend Unit

Upper Bend Units are shipped from the factory fully assembled at a pre-set angle of 30° (15° at each pivot point). The Upper Bend Unit is attached to a terminal end (End Drive or End Idler unit), or shipped separately to be attached on location to the Intermediate Sections when the conveyor has a horizontal run-out.

If the conveyor's angle of incline is other than 30°, it is recommended that the unit be reset to the required angle before the conveyor is installed. Use the following steps when resetting the unit's angle of incline:

1. Remove four Hex Head bolts (1/4" x 1/2") from the upper bend assembly. See Figure G - 9.
2. Loosen two 3/8" Hex Head bolts in each plate connection and swing each section to a setting that is 1/2 of the required angle.
3. Insert the 1/4" bolts into the appropriate hole (inset) in each of the four connections.
4. Retighten all bolts.

**Note:** The above instructions are provided for incline settings in 5° increments. If other than a 5° increment is required, use the following:

1. Follow steps 1 and 2 (above).
2. Retighten the 3/8" bolts.
3. Use a hole in the outer plate as a pilot and drill a new 1/4" diameter clearance hole in each plate connection.
4. Insert the 1/4" bolts into the new holes.
5. Retighten all bolts.

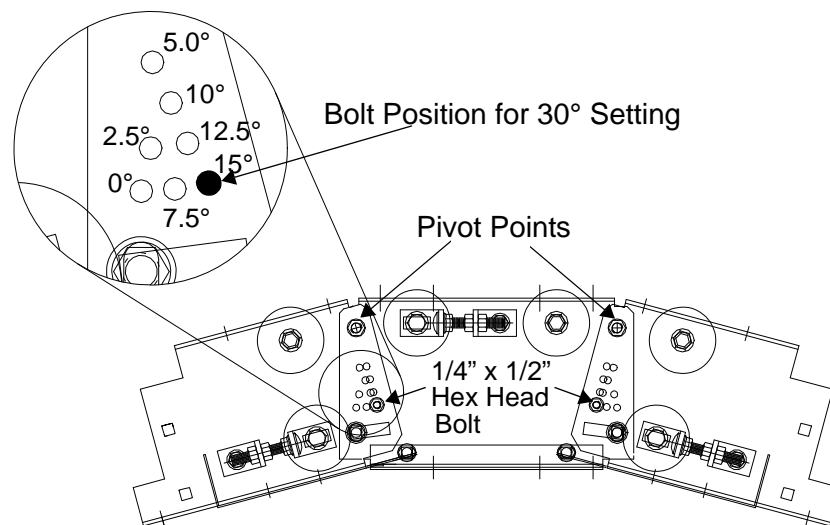

Figure G - 9 Upper Bend Unit

## Installing the Power Feeder and/or Jackknife Unit

Power Feeder Units are shipped from the factory fully assembled and ready to be attached to the intermediate bed section of the main inclined conveyor in the same manner as adjoining two Intermediate Sections. Mounting materials are shipped in hardware cartons. See Figure G - 5, Figure G - 10, Figure G - 11, and Figure G - 12.

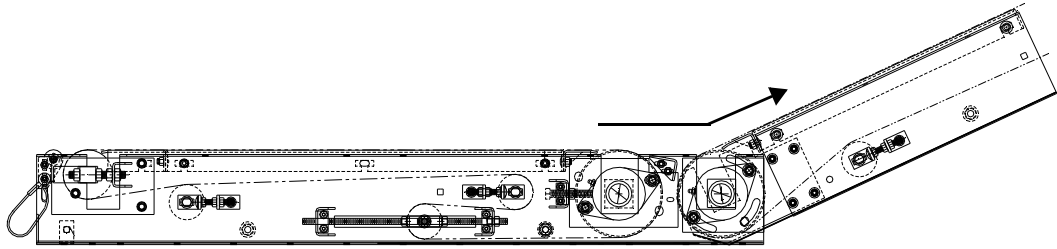

Figure G - 10 Power Feeder for Incline Conveyor

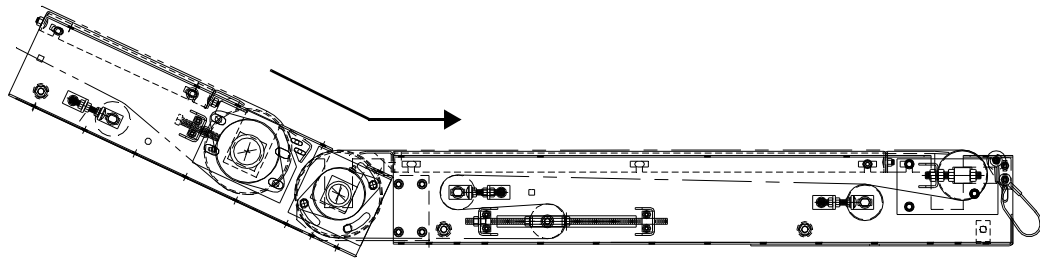

Figure G - 11 Power Feeder for Decline Conveyor

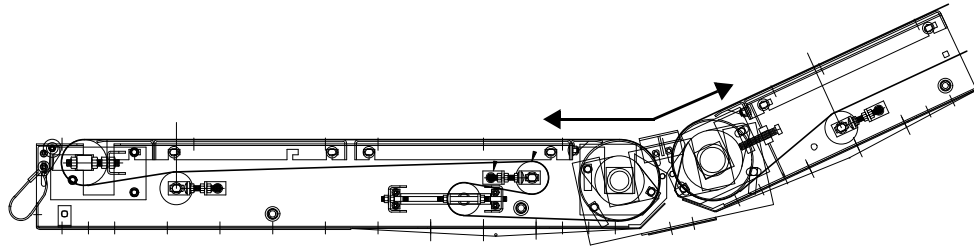

Figure G - 12 Power Feeder for Reversible Conveyor

## Connector Channel Assemblies

The adjoining terminal ends of two separate conveyors can be supported by a single floor support or ceiling hanger if the system is furnished with Connector Channel assemblies. See Figure G - 13. These assemblies consist of Connector Channels and Fill Flats that compensate for the difference in heights of various terminal ends. See Figure G - 14.

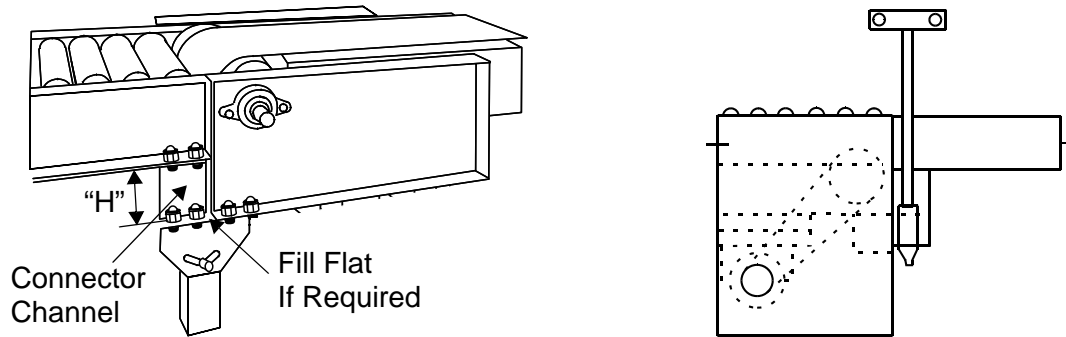

Figure G - 13 Connector Channel

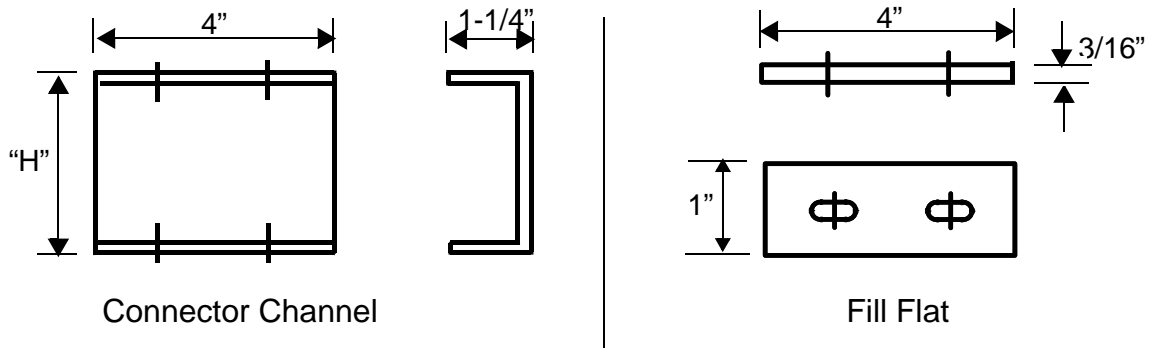

Figure G - 14 Connector Channel and Fill Flat Details

For example, when connecting a belt conveyor to a live roller or accumulator conveyor, the adjustable fill flats are inserted between the support top and the end plates of the roller type conveyor to keep the elevations of the belt and carrier rollers the same.

**Note:** These flats are not needed when connecting to another belt conveyor and may be discarded in such cases.

Each Connector Channel assembly includes:

- Connector channels with proper required dimensions
- Two adjustable fill flats
- Four 3/8" x 1" bolts with nuts, washers, etc.

**Note:** These parts are shipped in hardware cartons.

## Installing the Belt

Use the following steps to install the belt.

1. Before starting belt installation, make certain that:
  - all frame sections are level, properly aligned, and securely anchored,
  - all pulley and roller shafts are perpendicular to the conveyor frame,
  - all idler pulleys and rollers rotate freely,
  - no dips or humps exist along the conveyor bed surface, and
  - all sections are level.
2. Adjust all take-ups to their minimum take-up position.
3. Measure the required belt length.

For a short conveyor, thread a tape or rope through the conveyor following the path the belt will take and measure. Cut the belt to this length.

For longer units, the length of the conveyor can be doubled and 4'-0" added. This gives the approximate belt length required and cut to the approximate belt length.

4. Orient the belt properly on the unit.

For minimum friction (less belt drag), particularly on slider bed units, the brushed, non-glossy side of the belt must be face-down on the top side of the conveyor.

5. Thread the belt through the conveyor. Thread the belt through the bottom of the conveyor first. Position the belt near one end of the conveyor such that the brushed side of the belt is up and the first pulley to be encountered by the belt is the drive pulley. Large rolls of belting should be mounted on a shaft for ease of unrolling.

An alternative is to unroll the belt and lay it on the floor in large loops, taking care to avoid kinking the belt. The belt may then be pulled from the pile in the same manner it is pulled from a coil. Attach a suitable pulling clamp and cable to the lead end of the belt. See Figure G - 15. The clamp should distribute the pull evenly across the width of the belt. Then, with the assistance of a puller on the cable or rope, the lead end of the belt can be guided through the final path, around drive and take-up pulleys, over return rollers, around end pulleys, and finally, up to the top of the conveyor where it can be joined with the other end.

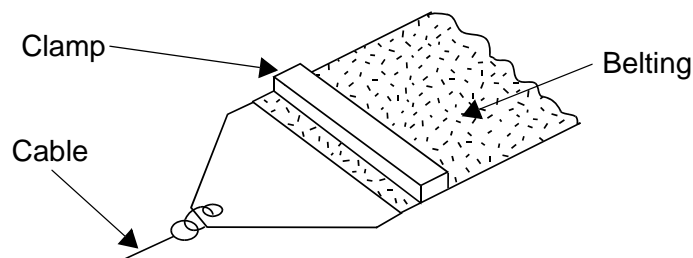

Figure G - 15 Belt Pulling Device

## Cutting the Belt Ends

Use the following steps to cut the belt ends:

1. Pull the belt ends together and secure them to the bed with appropriate clamps. See Figure G - 16. If excess belt remains, overlap the belt ends and pull the belt until the belt sag between the return rollers is about 1" (with conveyor take-up at minimum take-up position); then mark the cut line with chalk or pencil.

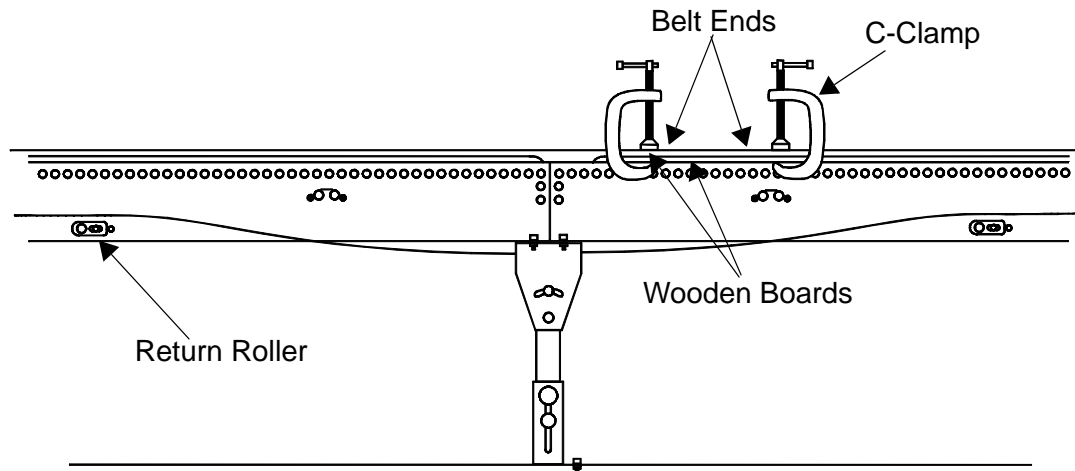

Figure G - 16 Clamping Belt Ends

2. Belt ends must be cut precisely square to ensure proper belt tracking and even distribution of the tension load through the belt splice.
  - Using chalk or pencil, mark the center of the belt at a number of points about 1 ft. apart in the vicinity of the planned cut.
  - Using a straightedge, mark the centerline of the belt by passing the line through as many center marks as possible.
  - Using a steel square, mark the cut line perpendicular to the drawn centerline.
  - Carefully cut the belt with a sharp knife or belt cutting tool.
3. Recommended: Corners on squared cut ends of the belt should be chamfered by cutting off a triangle measuring 1/2" (along the belt width) by 1-1/2" (measured along the belt length).
4. Recommended: Rough tops, ribs, chevrons, etc. should be skived back about 1" from the belt ends before lacing.

**Note:** Skiving is assumed by belting and lacing manufacturers when sizing belt fasteners for these types of belts.

## Splicing the Belt

Splice the belt with the supplied lacing. Follow the lacing manufacturer's instructions.

## Replacing the Belt(s)

When replacing the belt(s), it may be beneficial in certain applications to splice the belt on a bias to reduce noise. When the belt is spliced on a bias, Intelligrated engineering requires the angle of the splice to be less than 7 degrees. Use the table below as a guide for common belt widths and dimensions. Each end of the belt must be cut at the exact same angle to ensure proper belt tracking. Be sure to take the offset measurement before trimming 1/4" from the corners, so as not to exceed the maximum bias angle.

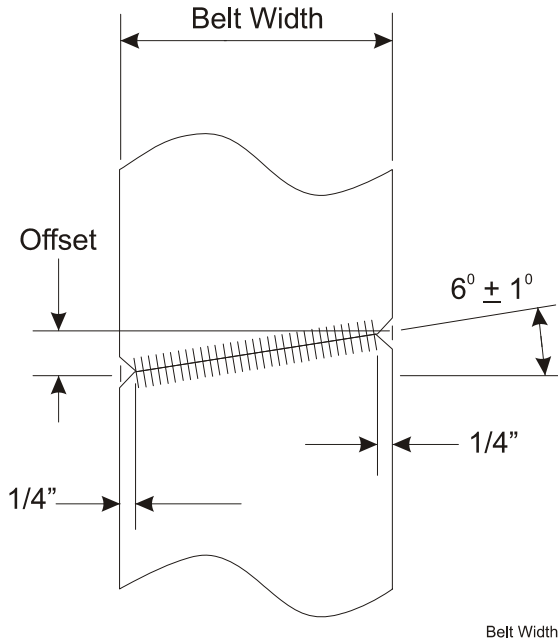

Common Belt Widths	Offset Dimension for 6 Degree Bias
12"	1-1/4"
18"	1-7/8"
24"	2-1/2"
30"	3-1/8"
36"	3-13/16"



---

## Installing Electrical Wiring

Electrical wiring must be installed by a competent licensed electrician. The licensed electrician must be familiar with the operation and adjustment requirements of the conveyor so that the conduit and apparatus do not interfere with required access.

A lockable disconnect switch, rated to the service, must be mounted near and wired to each drive motor. All power to be connected to the motor must be routed through the disconnect switch. This will permit local physical lockout of the motor by persons making repairs or adjustments to the drive.

After completion of the wiring, the electrician should “bump” each drive motor, and if necessary, modify the connections to achieve proper rotation for the required direction of belt travel.

## Pre-Start-Up Preparation

---

---

**CAUTION:** To prevent accidental start-up, make certain electrical power to the Power Unit is turned off and locked out.

---

---

## Pre-Operation Check List

The following describes the check list prior to equipment start-up:

1. Check conveyor elevation and adjust supports as needed.
2. Check conveyor alignment (lengthwise and width wise) with a spirit level. Adjust supports or add shims as needed and securely tighten all mounting bolts.
3. Check that all pulleys and rollers are mounted perpendicular (90°) to the direction of belt travel.
4. Check belt sag and adjust take-up pulley as needed. Do not over tension the belt.
5. Check driver/driven sprocket alignment with a straightedge. Securely tighten all sprocket fasteners.
6. Check drive chain tension and adjust as needed. Securely tighten all mounting bolts.
7. Check motor wiring connections.
8. Check other wiring connections and test all conveyor electrical controls for proper operation.
9. Check that all conveyor safety guards removed during the installation have been replaced.
10. Check that tools and all installation materials have been removed from the conveyor.
11. Check that the reducer lubricant is up to the oil level plug. If the reducer requires additional lubricant, refer to the manufacturer’s tag attached to the reducer before adding.  
Note: Before reinstalling the oil level and fill plugs, treat the plug threads to prevent oil leakage.
12. Review Safety Precautions listed in this Section. See “Safety Precautions” on page G - 2.

---

## Belt Tracking

At this point, the conveyor is properly installed, all sections are aligned, and all carrier rollers are level and square with the frame. The belt is installed with all pulleys, snub, and return rollers at right angles to the conveyor frame, and all pre-start-up precautions observed. Now you are ready to track the belt.

---

**WARNING:** Belt tracking is performed while the conveyor is running and is dangerous. Only trained and qualified personnel must perform the belt tracking function. The personnel must be instructed to always be alert for any unsafe condition and to use extreme care when tracking the belt.

---

## Principles of Belt Tracking

You must understand the principles of belt tracking in order to properly track the belt:

- **Crowned Pulleys** - Belts connecting parallel shafts tend to run toward that part of the pulley which is largest in diameter. Therefore, pulleys are crowned to keep the belt on center.
- **Taut Belt** - The belt must be sufficiently tensioned to not slip on the drive pulley. **DO NOT** overtighten.
- **Parallel Shafts** - If the pulley shafts are not parallel, the belt will creep toward the side where the shaft centers are closest. For pulley adjustment, see Figures G - 19 through G - 21.

## Belt Tracking Instructions

1. When first tracking the belt, station qualified personnel at each end of the conveyor to observe possible belt tracking problems.
2. It is seldom possible to make pulley shafts perfectly parallel. Corrective adjustments must be made with the snub rollers. See Figure G - 26 through Figure G - 28.
3. A common mistake is to adjust the end pulleys for any belt tracking problem. It is proper to adjust the end pulleys only for mis-tracking on the pulley at the discharge end of the conveyor. See Figure G - 19.
4. Note that the belt creeps toward the side of the pulley or snub roller that it touches first. Adjustments should be made accordingly. See Figure G - 18 through Figure G - 21.
5. All adjustments should be slight and you must allow sufficient time for the belt to react to the adjustment, (especially if the conveyor operates at slow speeds). Multiple revolutions of the belt are required for the belt to reach equilibrium.

## Examples of Belt Tracking

As shown in Figure G - 19 through Figure G - 21, the belt always creeps to the right side of the conveyor. The right side of the conveyor is the side to your right when you are facing in the direction of forward travel of the product. See Figure G - 17. For reversible conveyors, forward travel is that direction of travel which is used to convey the largest amount of product.

The terminal ends are identified by their location in relation to the forward direction of product travel.

The conveyor's infeed end (forward travel) is referred to as the "tail" end, and the discharge end is the "head" end. See Figure G - 18.

On reversible units, the head and tail end designations will remain the same for both directions of travel once the forward direction is established.

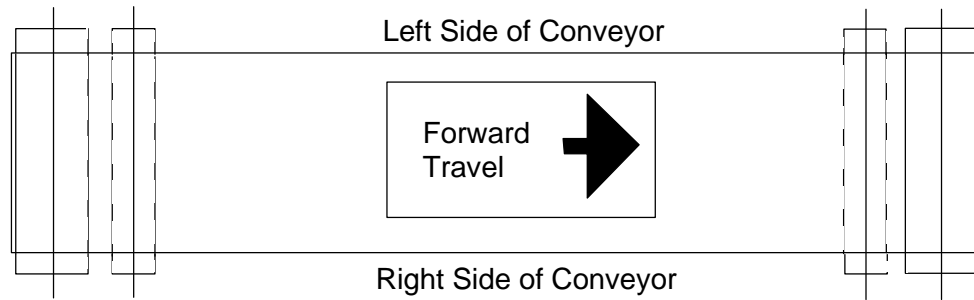

Figure G - 17 Direction of Travel

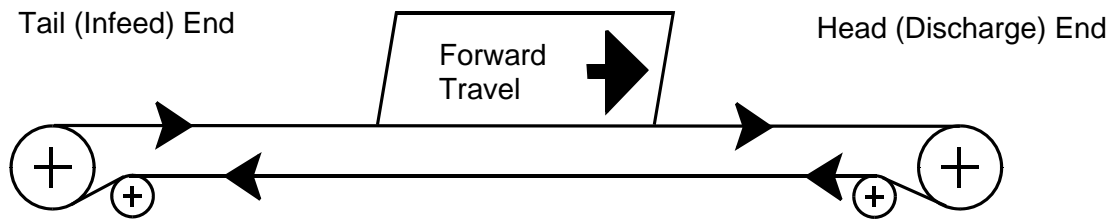

Figure G - 18 Product Travel From Tail End to Head End

During forward product travel, if the belt creeps to the right on the head pulley (drive/idler), adjust the right side of the head pulley in direction "F" (Forward) and/or the left side in direction "R" (Rearward). See Figure G - 19.

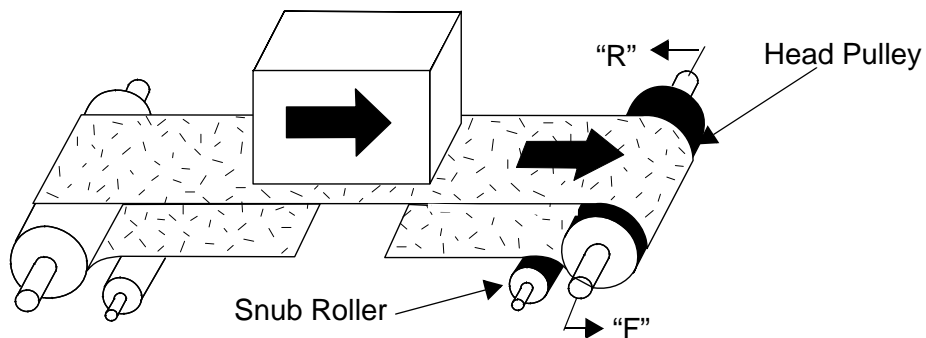

Figure G - 19 Adjusting the Right Side of the Head Pulley

During forward product travel, if the belt creeps to the right on the tail pulley, adjust the right side of the tail end snub roller in direction "R" and/or the left side in direction "F". See Figure G - 20.

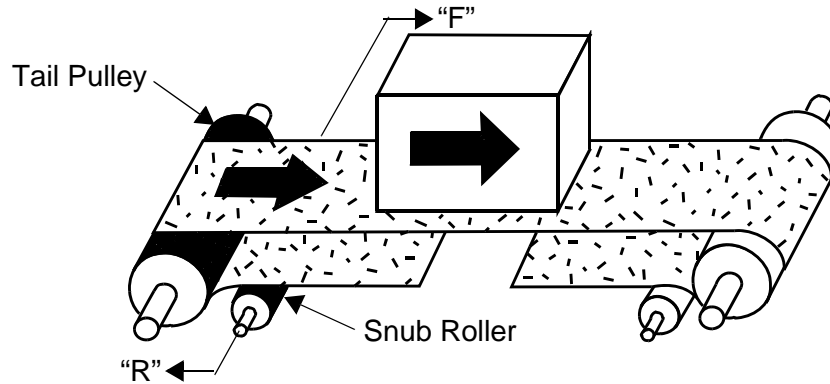

Figure G - 20 Adjusting the Right Side of the Tail End Snub Roller

During forward product travel, if the belt creeps to the right at the upper bend, adjust the right side of the upper bend roller A in direction "F" and/or the left side of upper bend roller B in direction "R". See Figure G - 21.

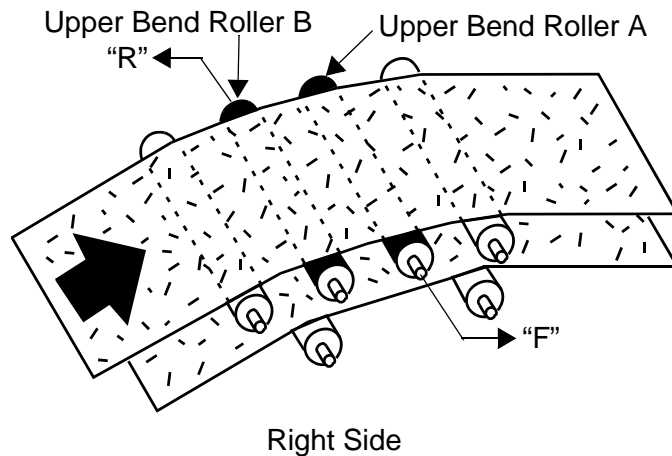

Figure G - 21 Adjusting Upper Bend Roller for Tracking the Upper Run of Belting

Proper installation is a key factor in tracking the belt at the Upper Bend. Make certain the unit is level (from side-to-side) and that both sides are adjusted evenly. See Figure G - 22.

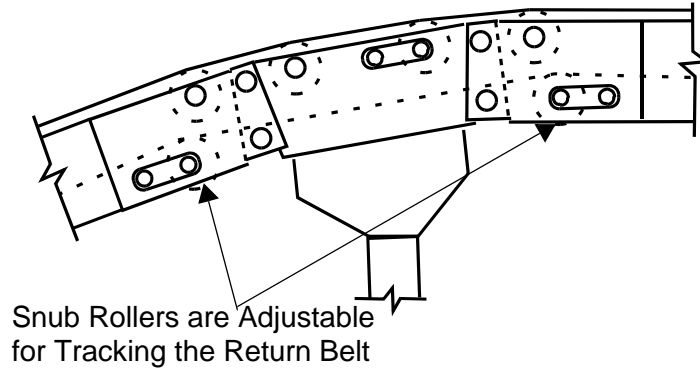

Figure G - 22 Adjusting Upper Bend Snub Rollers for Tracking the Return Run of Belting

In Figure G - 23 and Figure G - 24, the direction of product travel is not mentioned. This is necessary as the Intermediate Drives are reversible and may be installed as either right-hand or left-hand assemblies.

With the belt travel as shown in Figure G - 23, if the belt creeps to the near side of the drive and take-up pulleys, adjust the near side of snub roller A in direction "R" and/or the far side in direction "F."

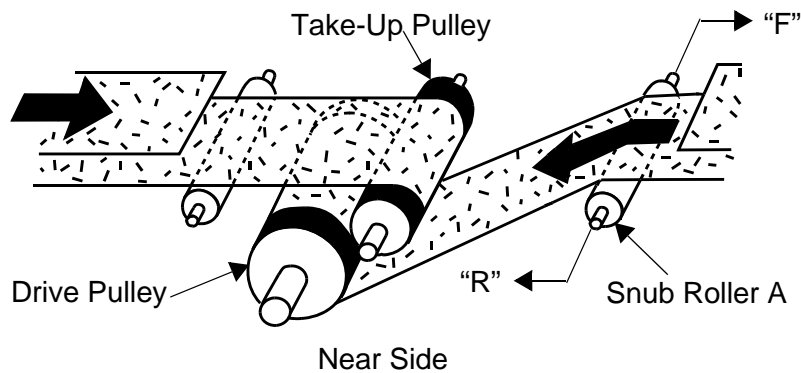

Figure G - 23 Adjusting the Near Side of the Snub Roller

With the belt travel as shown in Figure G - 24, if the belt creeps to the near side of the drive and take-up pulleys, adjust the near side of snub roller B in direction "R" and/or the far side in direction "F."

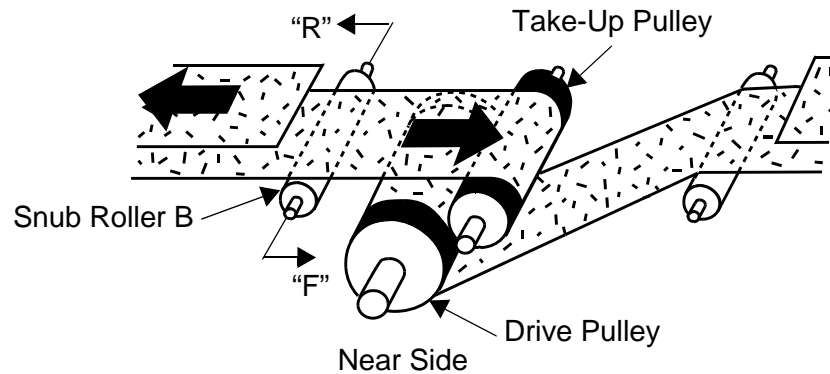

Figure G - 24 Adjusting the Near Side of Snub Roller B

### Belt Tracking Check List

1. Check the entire belt path for serious tracking problems that require immediate attention.
2. Watch the belt's position at a given point for at least one complete rotation. If the belt does wander off center and then returns back to the center position, there is no need to make any adjustments. When the belt wanders off center, it is caused by camber in the belt length which will tend to straighten out in time.
3. (Roller Bed Only) If the upper run of the belt moves off center in a particular section, check that section to see if the rollers are square to the frame rails. If they are not at right angles with the frame, the section(s) must be straightened.
4. If the upper run of belt runs "off-center" the full length of the conveyor, first make adjustments of the Snub Roller as shown in Figure G - 20. Then, if necessary, adjust the End Pulley as shown in Figure G - 19.
5. Observe the belt's return run and its position on each return roller. Adjust any roller that causes the belt to move off center.
6. If the belt mis-tracks at the Upper Bend Unit, adjust the Upper Bend and/or Snub Rollers as shown in Figure G - 21 and Figure G - 22.
7. If the belt mis-tracks at the Intermediate Drive, adjust the Snub Roller proceeding the drive as shown in Figure G - 23 and/or Figure G - 24.
8. On reversible unit, first track the belt in the forward direction of travel, then reverse the conveyor and repeat the tracking steps.

## Adjusting Belt Tension

Tension the belt by adjusting the Take-Up Pulley. See Figures G - 25 through G - 27. The adjustments must be made equally on both sides and in small increments.

Adjust the Take-Up Pulley so that the belt tension is just tight enough to prevent the belt from slipping on the Drive Pulley. Excess tension will reduce the life of the Belt, Lacing, Snub Rollers, and Pulley Bearings.

---

**WARNING:** Adjustment of the Take-Up Pulley may require the chain guard to be removed. When adjusting, be careful to stay clear of the chain and drive components.

---

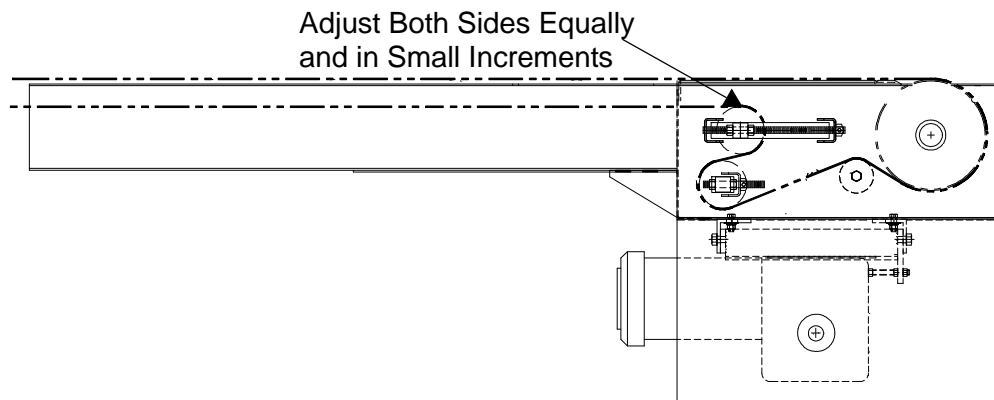
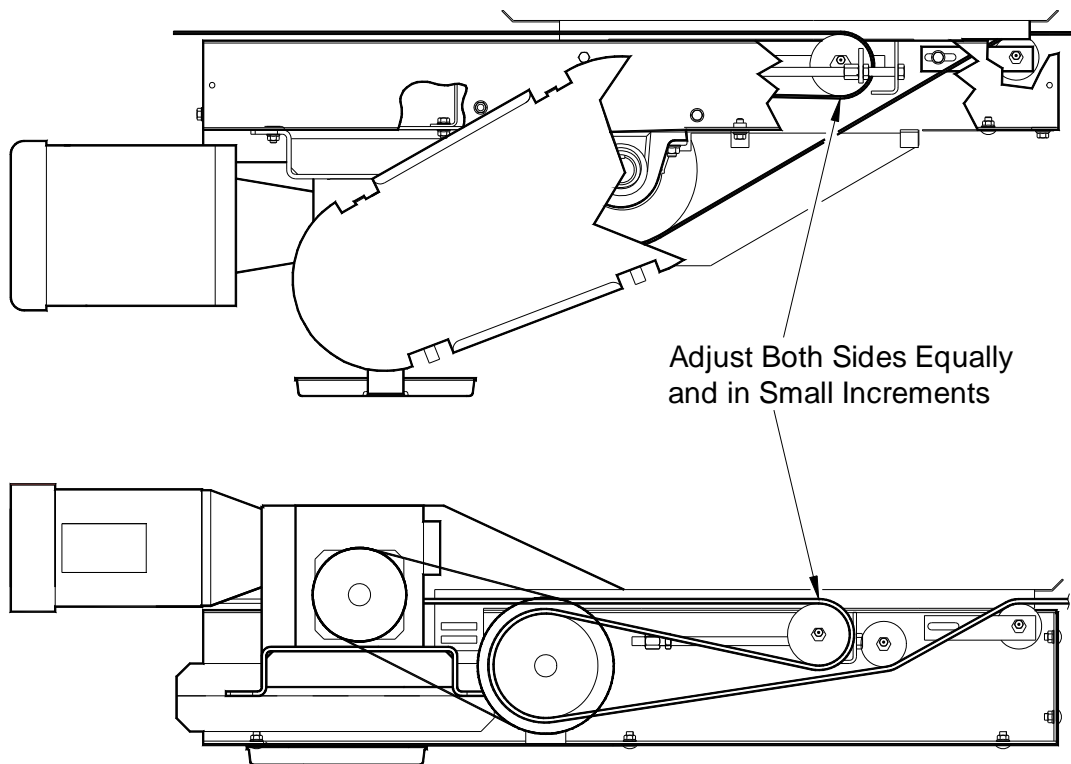

Figure G - 25 End Drive Take-Up



8100FKI011a

Figure G - 26 Intermediate Drive

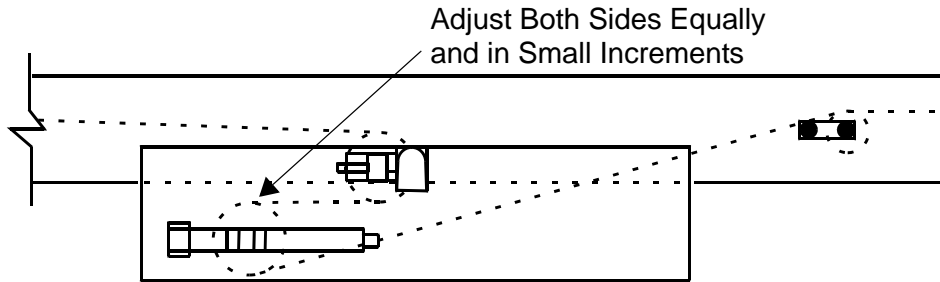

Figure G - 27 Auxiliary Take-Up

### Adjusting Snub Rollers

The assembly of the clips, bolts, etc. is common for all End Drive Take-Ups and Idlers. To adjust, loosen both the bolt and nut on one side and shift the roller as required.

End Drives also have a snub roller. Belt adjustment requires that the flanged hex bolt (A) be loosened before the roller can be shifted. See Figure G - 28.

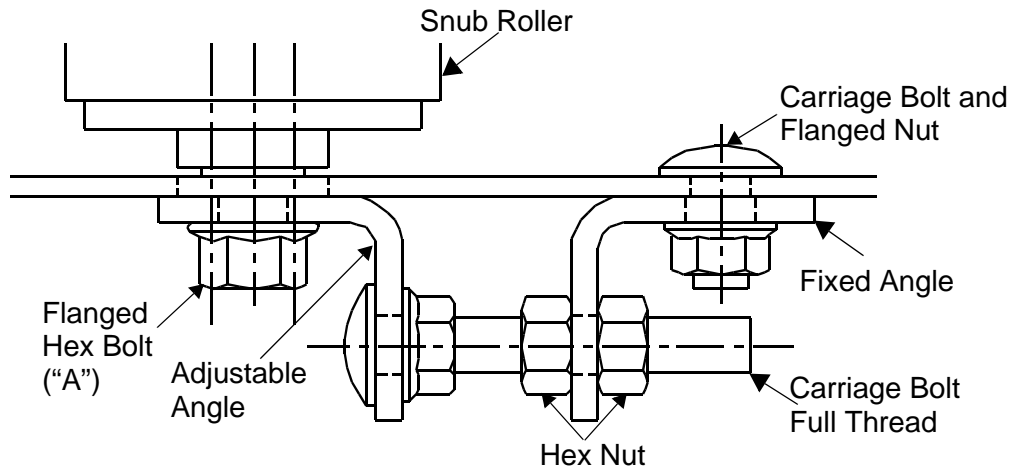

Figure G - 28 Adjustable Snub Roller Assembly



---

## SECTION H: MAINTENANCE

### General

The recommended inspection and maintenance functions described in this Section apply to intermittent-duty conveyor applications. Additional functions may be required for continuous-duty operation or extreme environmental conditions.

### Maintenance Safety

---

---

**WARNING:** Maintenance must be performed only by qualified personnel who are trained in normal and emergency operations of the conveyor and who are knowledgeable of all safety devices, their locations, and functions.

Before performing maintenance on a conveyor, make certain that the conveyor's power disconnect is locked in the OPEN position and tagged to prevent accidental or unexpected application of power.

Do not perform maintenance while the conveyor is running unless specifically instructed to do so in this manual.

Note: Other than belt tracking and checking chain tension, it is NOT necessary to have the conveyor turned ON to perform any of the work described in this section.

---

---

Before restarting a conveyor:

- Remove all foreign objects from the conveyor.
- Be sure that all guards and safety devices are properly installed and working.
- Make sure that all persons are clear of the conveyor and are aware that the conveyor is about to be restarted.

### New Installations

All newly installed equipment should be inspected frequently and serviced as needed during the first 40 hours of operation. See "Initial Start-up and Run-in Period" on page H - 1. Thereafter, an appropriate maintenance program should be established and followed. See Table H 1.

### Maintenance Logs

Maintenance logs should be kept on all conveyor installations. Each log sheet should show:

- The date when an Inspection or Maintenance function was performed
- Details of the Inspection or Maintenance function
- Names of personnel performing the Inspection or Maintenance function

### Initial Start-up and Run-in Period

#### Chain and Sprockets

Check the drive chain tension daily for the first week of operation, then monthly. Refer to the "Chain Maintenance" label on the inside of chain guard.

---

---

**WARNING:** Chain tension must be checked while the conveyor is running with the chain guard removed. When checking, be careful to stay clear of the chain and drive components.

---

---

## Power Unit Reducer

Grove and Reliance reducers are supplied with “lifetime” synthetic lubricants (Mobile SHC-634) that do not need to be changed after the unit is put into service.

**Note:** All reducers tend to run hot when first put into operation until the maximum break-in efficiency is reached (approximately 120 hours).

## Scheduled Inspections and Maintenance

Intervals indicated for performing inspections and maintenance should be considered for an 8 hour per day operation. An application may subject the equipment to conditions that would necessitate more frequent maintenance. This may best be determined by performing maintenance more frequently when the conveyor is first put into operation, and then lengthening the intervals based on experience.

Table H 1: Scheduled Maintenance

	Components	Item Check									
		Lubrication	Oil Level	Tension	Wear	Alignment	Fasteners	Set Screws	Proper	Physical	Operation
Weekly	Belt			X	X	X				X	
	Belt Lacing									X	
	Carrier/Belt Return Rollers									X	X
	Electrical Devices								X	X	X
	General Structure						X			X	X
	Power Unit - Reducer		X								
	Safety Guards/Devices								X	X	X
Monthly	Bearings - External						X	X		X	
	Drive Chains and Sprockets	X		X	X	X	X	X		X	
	Timing Belts and Sprockets			X	X	X	X	X		X	X
	Take-up/Idler Pulleys									X	X
	Power Unit - Motor						X			X	
	Power Unit - Reducer						X			X	
	Pulley Lagging									X	
	Supports and Hangers						X			X	
Semi Annually 1040 hrs.	Bearings - External	X									
	Power Unit - Motor	X									
	Power Unit - Reducer	X	X								

---

## Daily Inspections

General walk-through inspections of the conveyor equipment during daily plant operation is recommended. Listen for unusual noises and carefully observing the system. For continuous duty applications, conduct conveyor inspections once each shift.

Frequently check equipment safety guards, warning signs, lights, and alarms associated with the operation of the conveyor system and keep them in good condition to ensure the safety of all plant personnel. Any unusual conveyor noise, oil leaks, and operational problems should be immediately reported and promptly corrected.

## Weekly Inspections

### Belting

Check that the belt is tracking properly along the entire conveyor length. Make appropriate adjustments of snub rollers, etc. If required; check that the belt tension is sufficient to prevent the belt from slipping on the drive pulley under the maximum required load. Remove any buildup of product spillage.

### Belt Lacing

Check the lacing for damage or protrusions which might cause damage to the conveyor or product. If the lacing needs to be replaced and the take-up permits, cut both ends of the belt square and re-splice. If the take-up does not permit, cut and lace in a short length of belting (1'-0" long minimum).

### Carrier and Belt Return Rollers

Check that all rollers are in place and turning freely. Remove any buildup of dirt and/or product spillage. Take care in keeping cleaning materials from coming in contact with the ball bearings.

### General Structure and Operation

Check the conveyor's physical condition, looking for loose fasteners, damaged or wearing components. Listen for unusual noises such as squeaking bearings, chains jumping sprockets, etc.

Check that the conveyed product travels along the length of the conveyor without obstruction of hesitation.

### Power Unit Reducer

Check for signs of oil leakage on the floor and/or in the drip pan. If leakage persists or the amount of leakage is significant, repair or replace the unit. Until corrections are made, closely monitor the unit's oil level.

### Safety Guards and Devices

Check that the safety guards, warning signs, light, and alarms are in place and in proper working condition. Check that all Emergency Stop pull-cords and/or push buttons are functioning properly.

### Electrical Devices

Photocells, proximity sensors, limit switches, etc. should be periodically inspected and adjusted as needed. Lenses and reflectors on photoelectric devices should be wiped clean

---

on a daily basis. For additional maintenance provisions, refer to the appropriate vendors instructions provided.

## Monthly Maintenance

### External Bearings

Check that all mounting bolts, set screws, etc., are securely tightened, and that no lubricant is coming out of the seals. Listen for any unusual noises.

### Internal Bearings

Check that the bearings are fully-pressed into the roller tube, and that the lubricant is not coming out of the seals. Listen for any unusual noises.

### Power Unit Motor

Remove any build-up of dirt/dust around the motor vent openings. Check that all mounting bolts are securely tightened and that the motor lead wires are securely connected.

Unless specified, wick-oil sleeve bearings should be lubricated every 2000 to 4000 hours. After the first 4000 hours of operation lubricate with 3 or 4 drops of light grade mineral oil or SAE10W motor oil. Refer to the motor lubrication plate or vendors instruction tag(s).

### Power Unit Motor/Brake

Due to normal wear, the brakes require periodic inspection and adjustment. For instructions, refer to the vendors installation and maintenance manual or contact the manufacturer for additional information.

### Power Unit Reducer

Check the oil level while the unit is warm, but not running. If required, add oil through the "fill" hole until the oil begins to run out of the "oil level" hole. All standard reducers are filled by the manufacturer with a synthetic gear lubricant. When replenishing the oil, be sure to use the same brand and type. DO NOT MIX lubricants. For further information, refer to the instruction tag attached to the unit.

To prevent oil leakage, apply Teflon tape or Permatex to the threads of the fill plug and oil level plug before reinstalling. Properly install and tighten the plugs before putting the unit back into operation.

### Power Unit Sprockets

Check sprocket alignment by placing a straight edge across the face of the sprockets simultaneously.

Inspect chain sprockets for need of lubrication. If required, lubricate the chain lightly with SAE 30 oil. DO NOT use grease. Also check teeth for wear. Realign if required,

### Power Unit Chains

Lubricate and check tension per instructions given on the "Chain Maintenance" label located on the inside of the chain guard. Remove any dirt or dried oil with a kerosene soaked rag.

## Power Unit Timing Belts

Adjust reducer to remove any belt slack and achieve a snug belt tension.

Use the following steps to check belt tension:

1. Measure the center distance between the driver and driven sprockets to determine the belt span length. See Figure H - 1.
2. Determine the correct deflection for the span as follows: Deflection = Span Length ÷ 64.
3. Use a spring-scale tension checker (possible source Browning) to determine the force required to produce the required deflection. See Table H 2.

Table H 2: Timing Belt Deflection/Force

Belt		Deflection
Pitch	Width	Force
8mm	12mm	7 lbs.
	22mm	15 lbs.
	35mm	20 lbs.
Pitch	42mm	23 lbs.

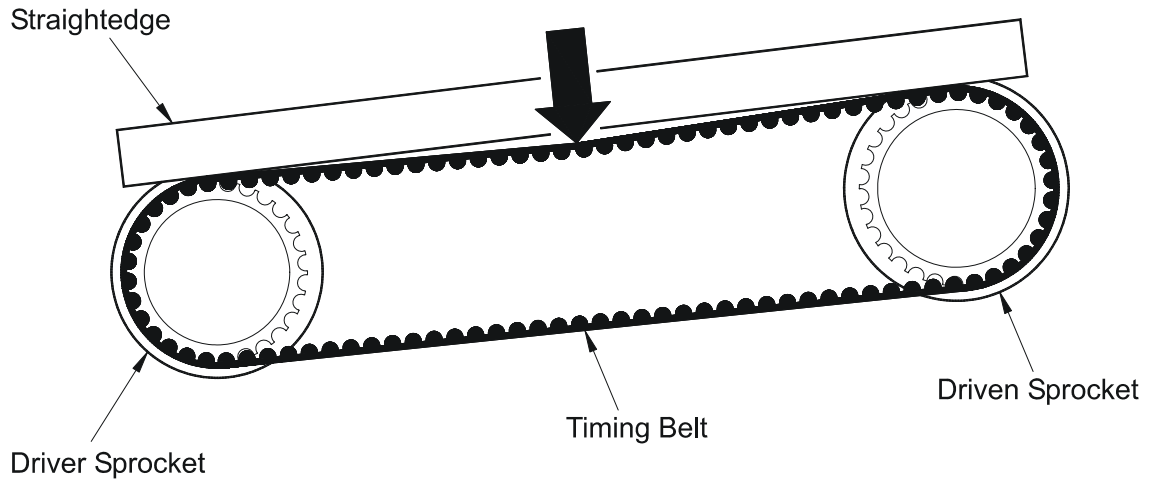

8100FKI013a

Figure H - 1 Measuring Timing Belt Deflection

### Drive Sprockets

Check the alignment by placing a straight-edge across the face of both sprockets simultaneously. Also check for wear on the sprocket teeth and side bars of the chain. If loose, tighten the sprocket fasteners.

### Drive Pulley and Lagging

Check the pulley alignment and make certain that all mounting bolts are securely tightened. Check for worn or damaged lagging on the drive pulley. Repair or replace as required.

---

## Supports and Hangers

Check that all floor supports and/or ceiling hangers are in good physical condition and have not been damaged. Check that all fasteners are securely tightened and that none are missing.

## Semi-Annual Maintenance

### Power Unit Motor

Units up to 5 HP are lubricated for life. For 7.5 HP motors, refer to the manufacturer's motor lubrication plate or operating instruction tag wired to the motor.

### Power Unit Reducer

Check that all fasteners are secure.

### External Pulley Bearings

All external bearings have lubed-for-life bearing cartridges, and do not require periodic lubrication.

If desired, the bearings may be re-lubricated using the grease-fitting that is provided in all bearing housings. Once grease is added, the bearing must be re-lubricated every 6 months with a lithium based ball bearing grease or compatible grease conforming to NLG1 Grade 2 consistency.

Add the grease slowly and sparingly while the pulley is rotating until a slight showing of grease forms around the seals. **DO NOT OVER LUBRICATE.** Too much grease may damage the seals. If a bearing is over greased; remove the fitting to allow the excess grease to escape. Replace the fitting and wipe clean before putting the conveyor back into operation.

### Internal Bearings

Check that the bearings are fully-pressed into the roller tube, and that the lubricant is not coming out of the seals. Listen for any unusual noises.

**Note:** For 2-1/4" diameter knife edge pulleys lubricate with Valvoline #633 every 1000 hours.

## Replacing the Belt(s)

When replacing the belt(s), it may be beneficial in certain applications to splice the belt on a bias to reduce noise. When the belt is spliced on a bias, Intelligrated engineering requires the angle of the splice to be less than 7 degrees. Use the table below as a guide for common belt widths and dimensions. Each end of the belt must be cut at the exact same angle to ensure proper belt tracking. Be sure to take the offset measurement before trimming 1/4" from the corners, so as not to exceed the maximum bias angle.

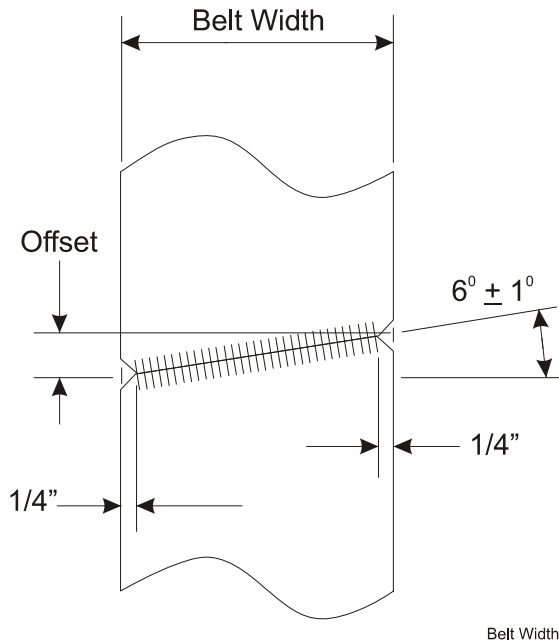

Common Belt Widths	Offset Dimension for 6 Degree Bias
12"	1-1/4"
18"	1-7/8"
24"	2-1/2"
30"	3-1/8"
36"	3-13/16"

## Troubleshooting

Basic troubleshooting provisions are outlined below. For troubleshooting for the specific conveyor system installed, always check the maintenance information. Basic troubleshooting is outlined in Table H 3.

**CAUTION:** Do not clear jams or reach into any unit before first turning off the equipment power source(s) and making certain that all moving parts are fully stopped. To avoid personal injury or equipment damage, lockout and tagged the conveyor operation control(s) before attempting to correct any malfunction.

Table H 3: Basic Troubleshooting Problems and Solutions

Problem	Cause	Solution
Conveyor does not start.	Electrical power shut off or control circuit NOT energized.  System control devices (photo-cells, limit switches, etc.) out of adjustment or defective.  Motor overload block open.	Check that system control panel(s) are energized. Be certain emergency stop devices are not activated.  Adjust or replace.  Check conveyor drive system and overload sizing before resetting.
Conveyor shuts off.	Accumulation photocell or other control device(s) actuated or defective.  Emergency stop activated.  Power or component failure at system control center.  Motor overload.	Check conveyor accumulation or obstruction of control device; replace control device if defective.  Correct condition and reset according to control logic.  Refer to vendor manuals.  Check conveyor drive system and overload sizing before re-starting.
One part of belt creeps to one side.	Belt ends not cut square.	Cut the belt ends perfectly square using a T-square.



Table H 3: Basic Troubleshooting Problems and Solutions (Continued)

Problem	Cause	Solution
Entire belt creeps to one side.	<p>Improper loading of belt.</p> <p>Belt shifts to low side. The base structure or conveyor frame is not level or is crooked.</p> <p>Alignment of pulleys; drive, tail, pulleys, or snub rollers are out of line or not perpendicular with the center line of the conveyor.</p> <p>Underside of the belt is dirty.</p>	<p>Center the product on the belt. Load in direction of travel.</p> <p>Stretch a string along the edge of the frame, check alignment of the frame and correct. Next, check the level of support structure.</p> <p>Use a T-square against the edge of the conveyor to recheck and square the pulleys.</p> <p>Remove foreign matter, because it creates a new crown on the pulley/roller face adversely affecting the tracking.</p>
Belt creeps to one side in head (discharge) pulley area.	Head pulley is out of alignment (not perpendicular with the center line of the conveyor).	First, adjust the snub roller. Second, realign the head pulley by advancing (belt travel direction) the end of the pulley to which the belt has shifted.
Belt creeps to one side in tail (infeed) pulley area.	Tail pulley is out of alignment (not perpendicular with the center line of the conveyor).	First, adjust the snub roller. Second, realign the tail pulley by advancing (return belt travel direction) the end of the pulley to which the belt has shifted.
Belt wanders irregularly.	<p>The conveyor is over-belted. This results in the belt being too stiff to properly operate over the pulley diameters.</p> <p>Off center or improper loading.</p>	<p>Change to the proper belt or use pulleys with larger diameters.</p> <p>Correct loading procedure.</p>
Edge wear is excessive.	<p>Belt edges fold up on conveyor guards and frame.</p> <p>Belt shifts to opposite side and rubs excessively due to side loading.</p> <p>Refer to previous Belt Problems to eliminate edge rubbing.</p>	<p>Remove the rough areas on the conveyor guards or frame.</p> <p>Loading in direction of belt travel will improve this condition.</p>

Table H 3: Basic Troubleshooting Problems and Solutions (Continued)

<b>Problem</b>	<b>Cause</b>	<b>Solution</b>
Belt fasteners pulling out.	Fasteners are incorrect size	Re-lace the belt with proper size fasteners.
	Too much tension on belt.	Relieve tension until belt will run without slipping on the drive pulley.
	Pulley diameters too small for the thickness of belt used.	Replace with larger diameter pulleys or thinner belt, if practical.

**SECTION I: PARTS IDENTIFICATION**

**General Information**

The purpose of this section is to identify parts for a quality preventative maintenance program and to minimize the chances for extended down time.

The following pages illustrate the location of these parts as they apply to each particular unit. Keep in mind that these illustrations only apply to the standard product line. These items will show on the bill-of-material as a coded item.

There will be items on the bill-of-material such as gearmotors, sprockets, chain, etc., that will show up on the price sheets only.

**Intermediate Sections**

**Roller Bed**

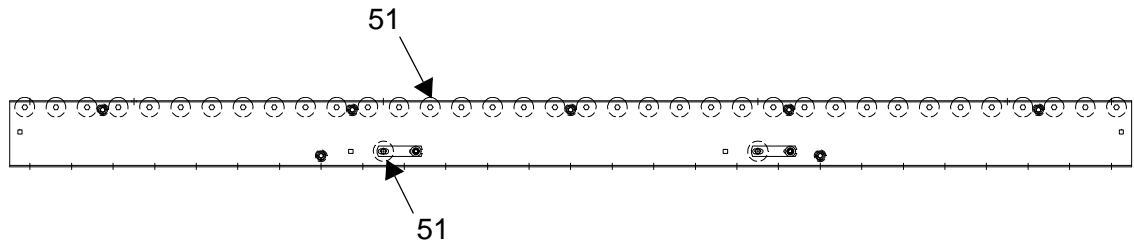

Figure I - 1 Roller Bed Intermediate Section

**Slider Bed**

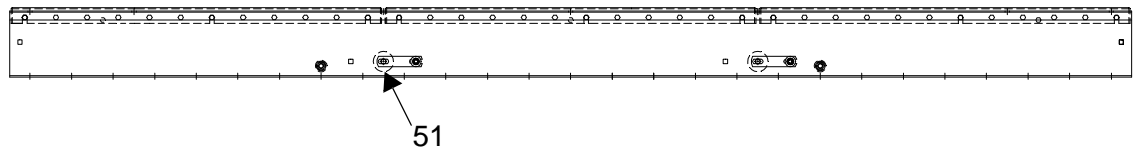

Figure I - 2 Slider Bed Intermediate Section

**Box Bed**

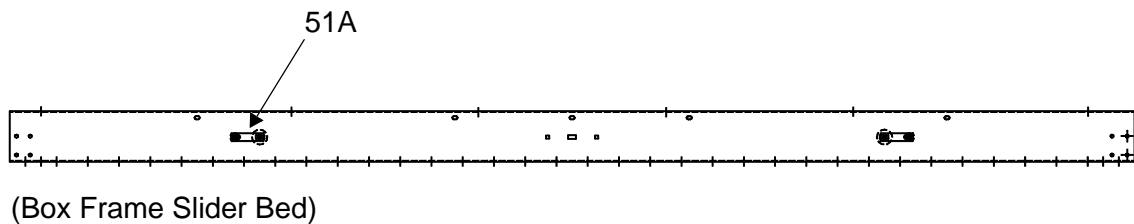

Figure I - 3 Box Bed Intermediate Section

## End Drives

### Series 400 with Take-Up

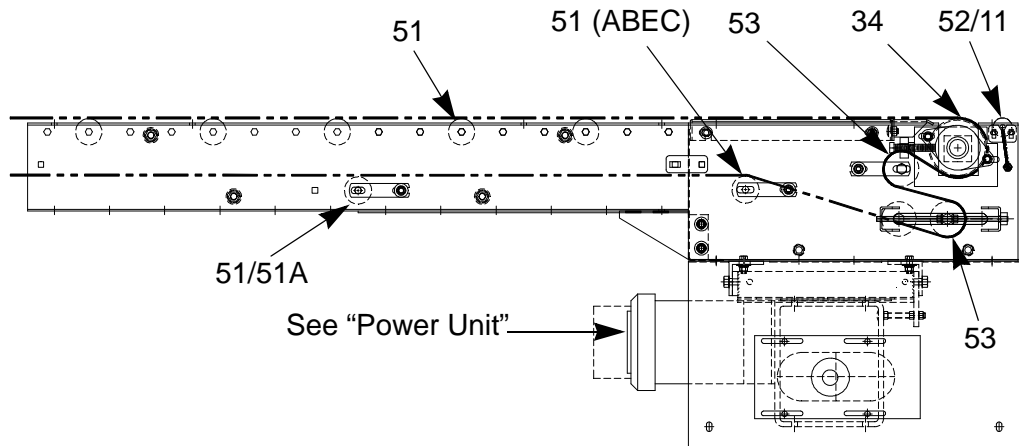
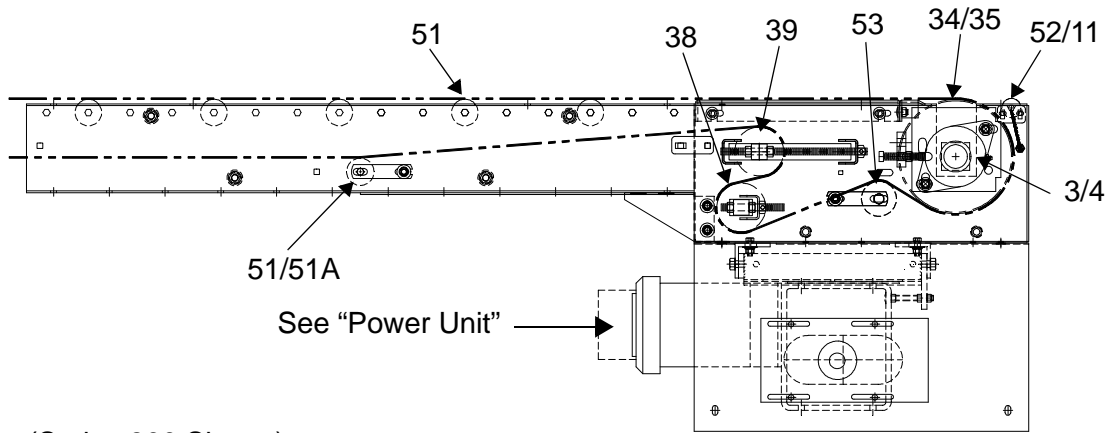

Figure I - 4 End Drive - Series 400 with Take-Up

### Series 600 and 800 with Take-Up



(Series 800 Shown)

Figure I - 5 End Drive - Series 600 and 800 with Take-Up

## End Idlers

### Series 400, 600, and 800

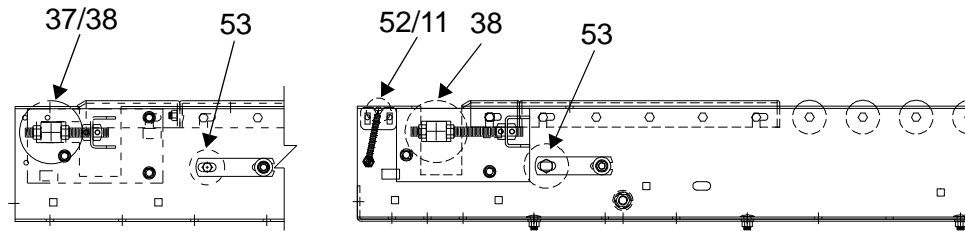

Figure I - 6 End Idlers - Series 400, 600, and 800

### Knife Edge Assembly

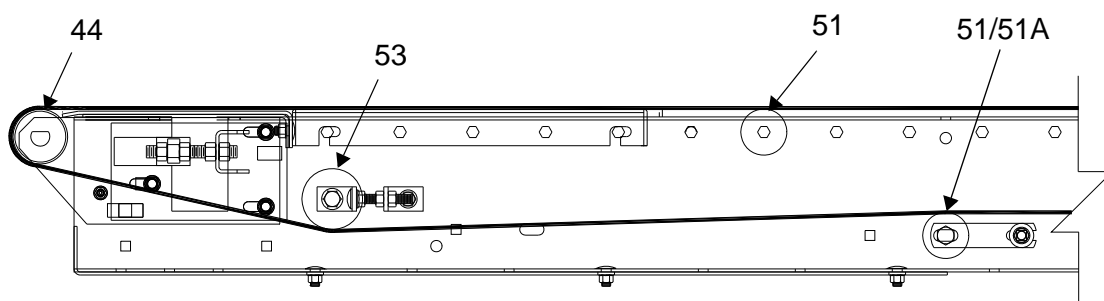
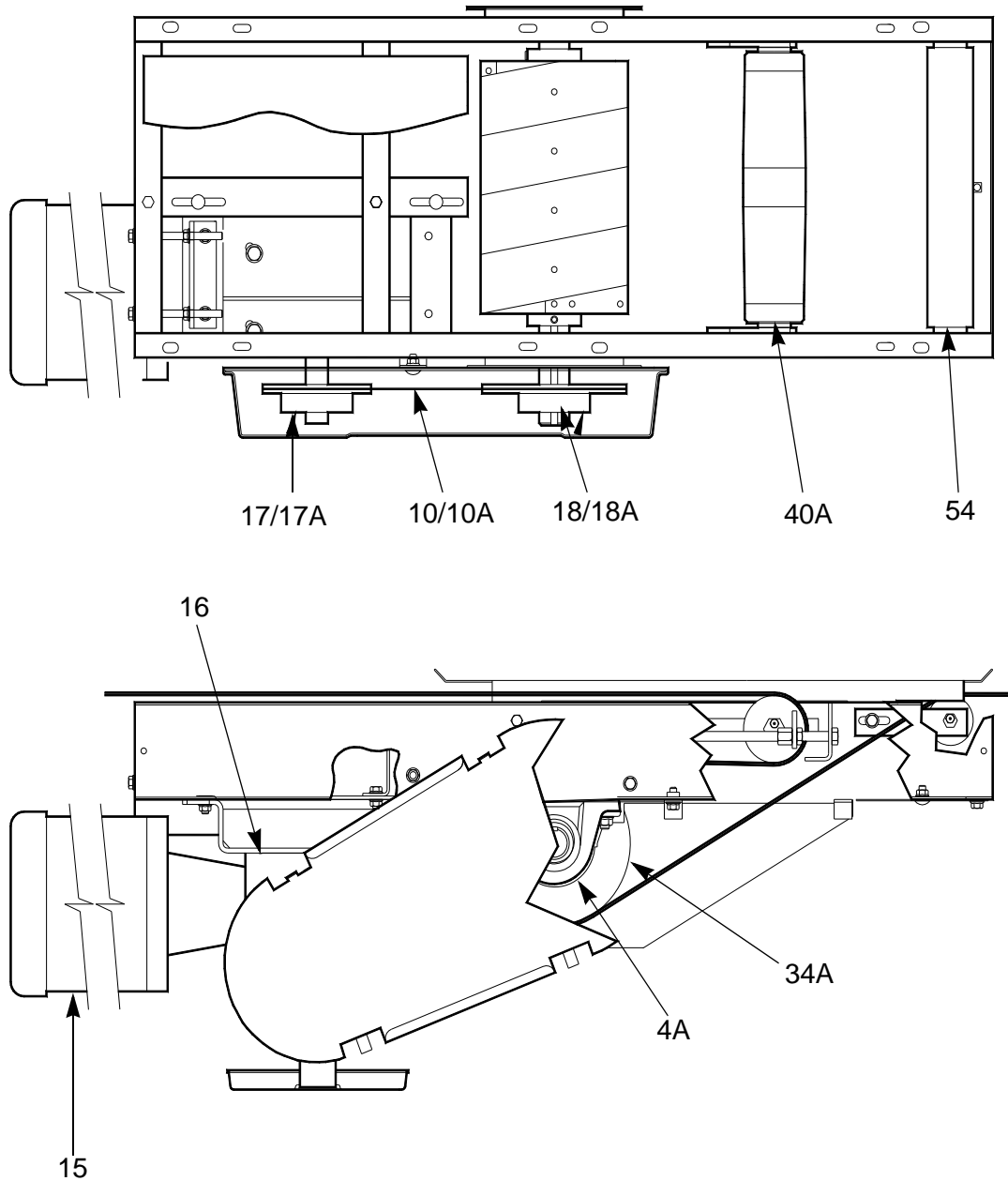

Figure I - 7 End Idler - Knife Edge Assembly

# Intermediate Drives

## SA2000 - Intermediate Section



8100FKI005a

Figure I - 8 SA2000 - Intermediate Section

SA2001 - Intermediate Section - Low Profile

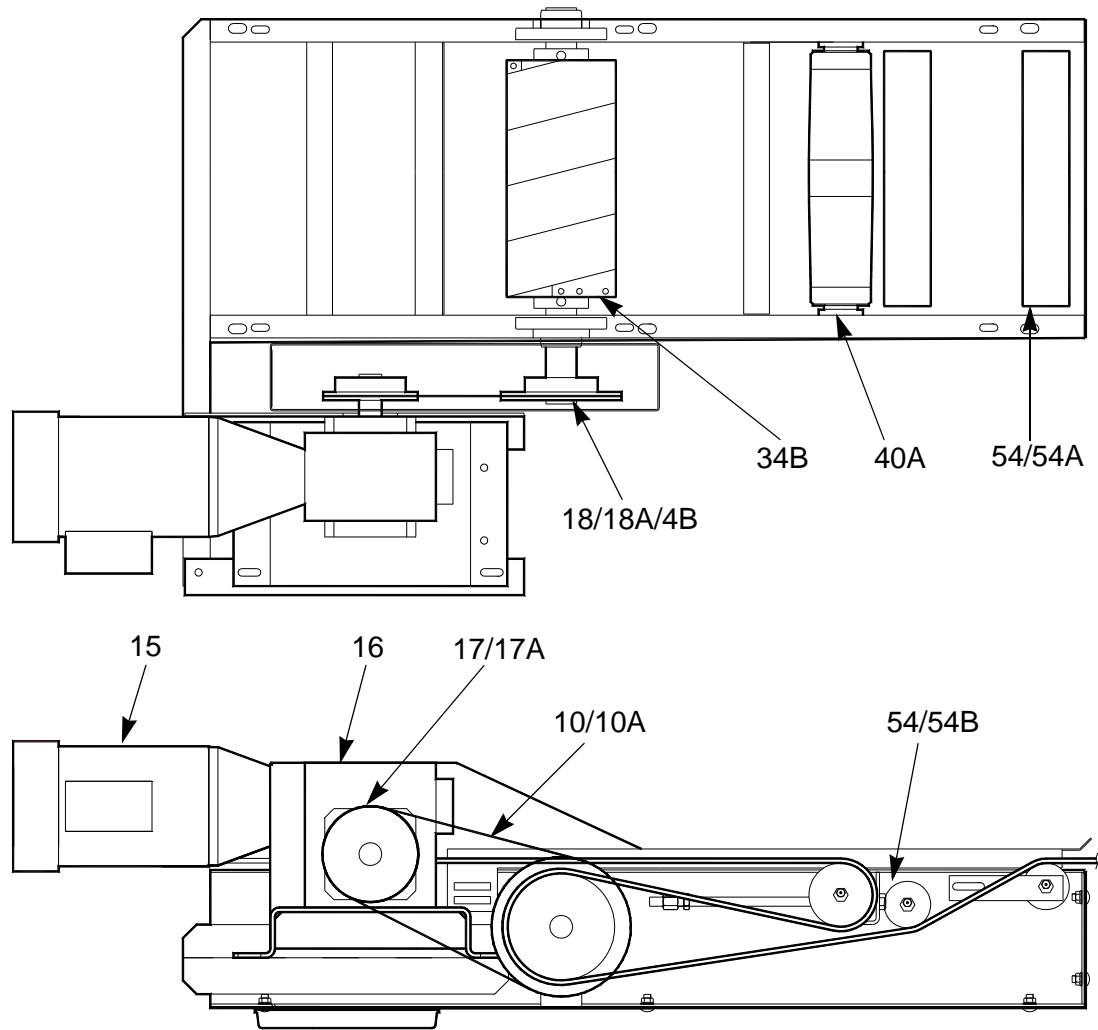

8100FK1006

Figure I - 9 SA2001 - Intermediate Section - Low Profile

---

## Auxiliary Take-Up Sections

### Manual (3.5" Pulleys)

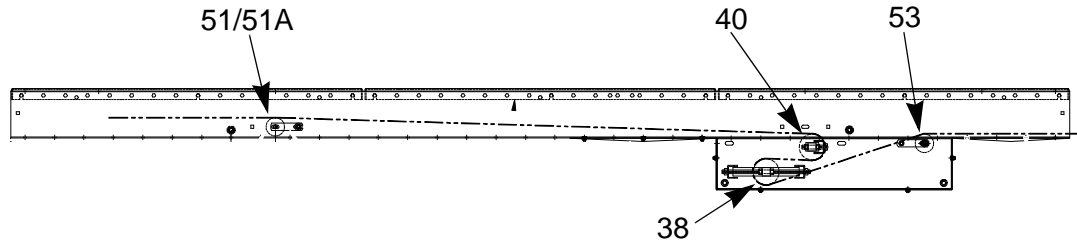

Figure I - 10 Auxiliary Take-Up Section - Manual (3.5" Pulleys)

### Manual (6" Pulleys)

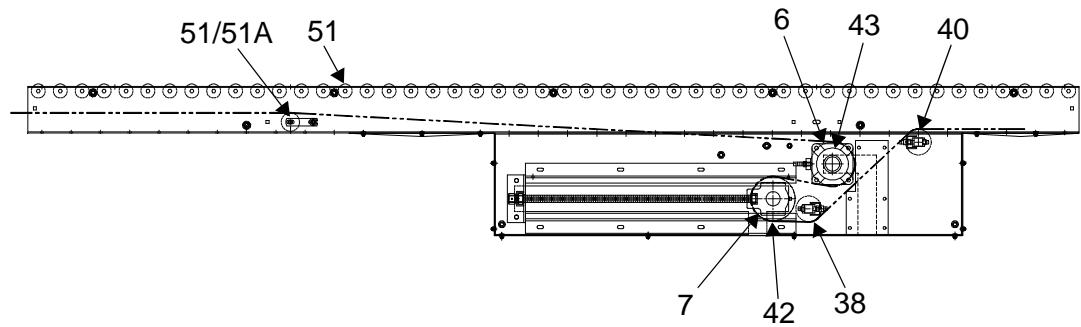

Figure I - 11 Auxiliary Take-Up Section - Manual (6" Pulleys)

### Automatic (Air) (6" Pulleys)

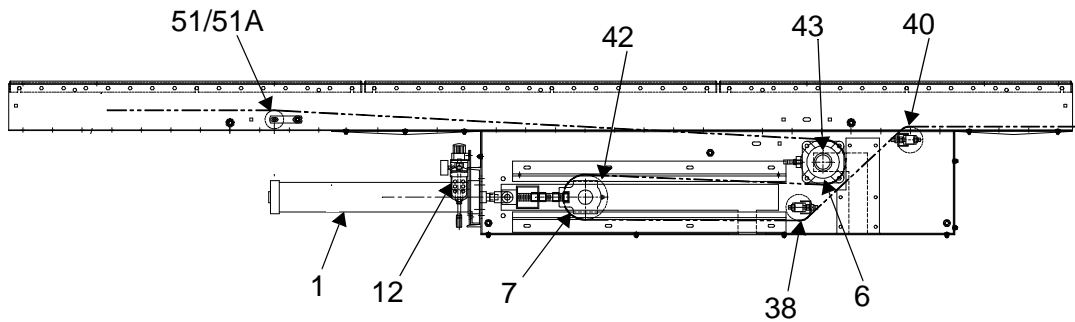

Figure I - 12 Auxiliary Take-Up Section - Automatic (Air) (6" Pulleys)



## Spring Take-Up

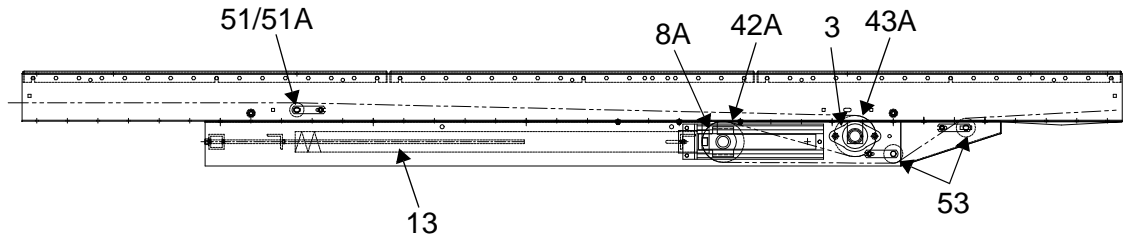

Figure I - 13 Spring Take-Up Section

## Upper Bend Sections

### 1.9" Rollers

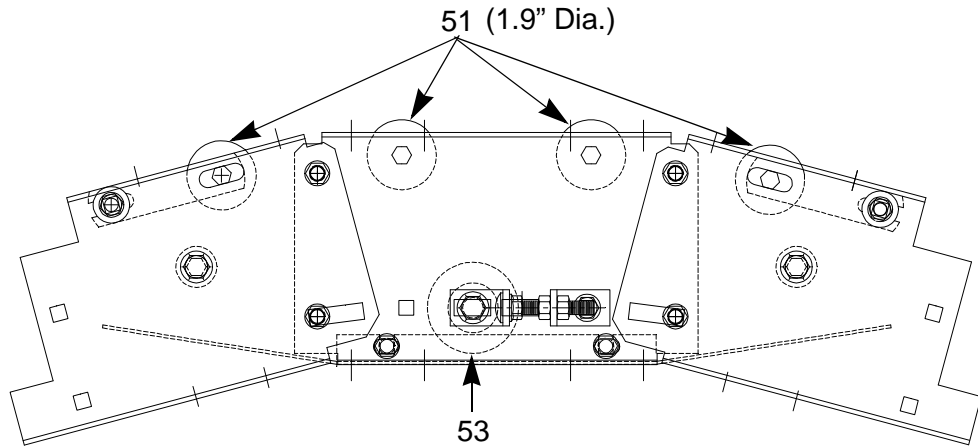

Figure I - 14 Upper Bend Section - 1.9" Rollers

### 2.5" Rollers

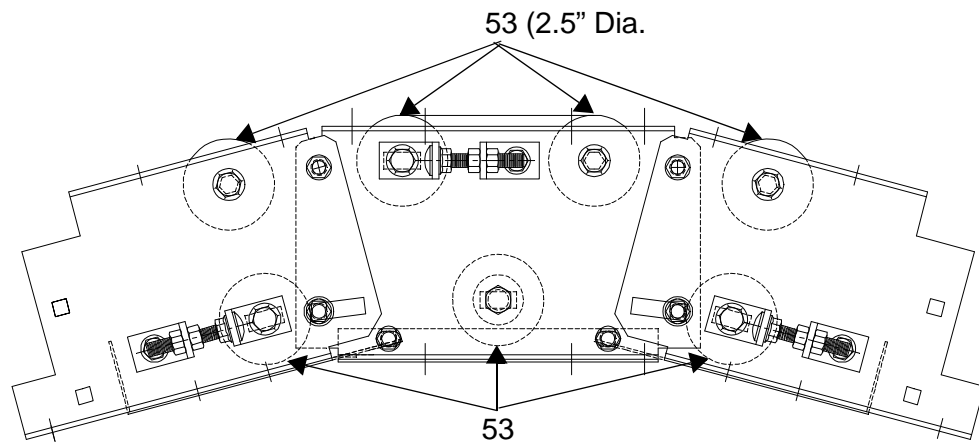
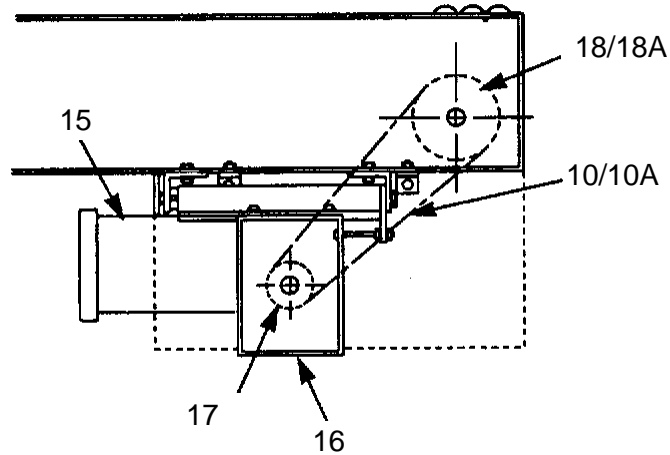

Figure I - 15 Upper Bend Section - 2.5" Rollers

# Power Units

## Under-hung Mount



(RH Assembly Shown)

Figure I - 16 Power Unit - Under-hung Mount

## Side-Mounted

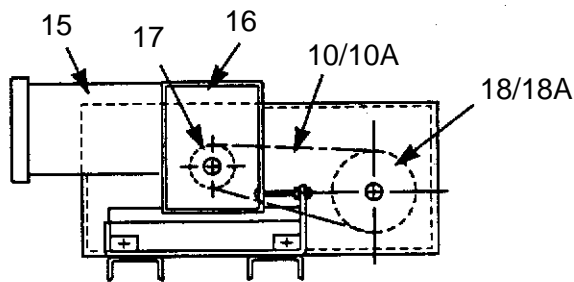

(RH Assembly Shown)

Figure I - 17 Power Unit - Side-Mounted

Table I 1: Reducer Assembly Designation

Under-hung Mount			Side-Mount		
Assembly	Brand	Designation	Assembly	Brand	Designation
Series 4/6/800 (RH-Shown) SA2000 (RH-Shown)	Grove	3	Series 4/6/800 (LH-Opp) SA2001 (LH-Opposite)	Grove	2
	Reliance	L1		Reliance	K1
Series 4/6/800 (LH-Opp) SA2000 (LH-Opposite)	Grove	2	Series 4/6/800 (RH-Shown) SA2001 (RH-Shown)	Grove	3
	Reliance	K1		Reliance	L1

**Driven Jackknife**

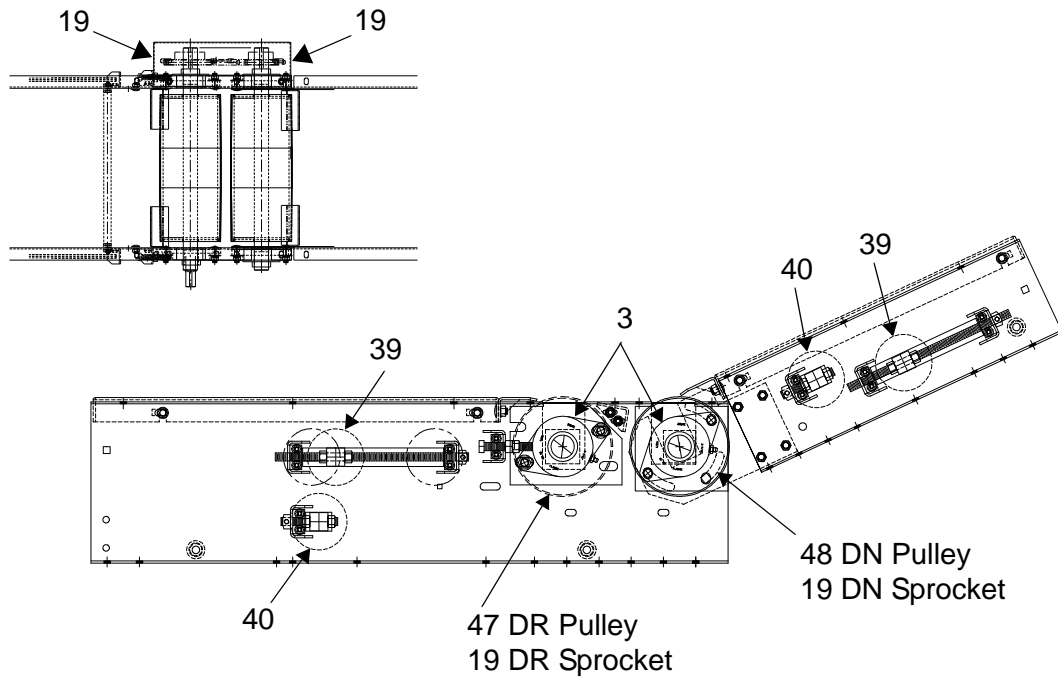

Figure I - 18 Driven Jackknife

**Non-Driven Jackknife**

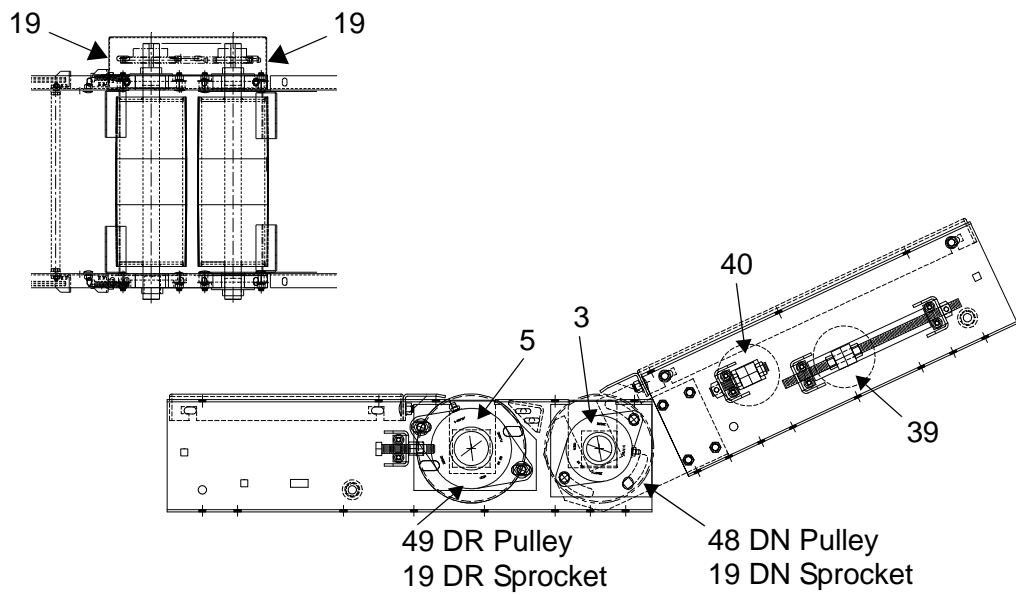

Figure I - 19 Non-Driven Jackknife

# Power Feeders

## Incline

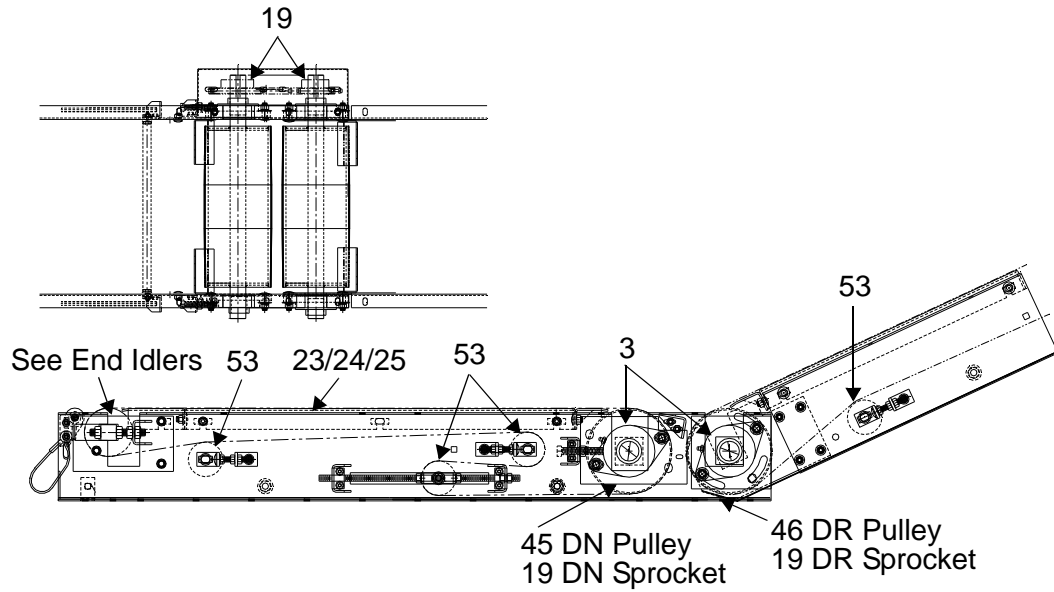

Figure I - 20 Power Feeder - Incline

## Decline

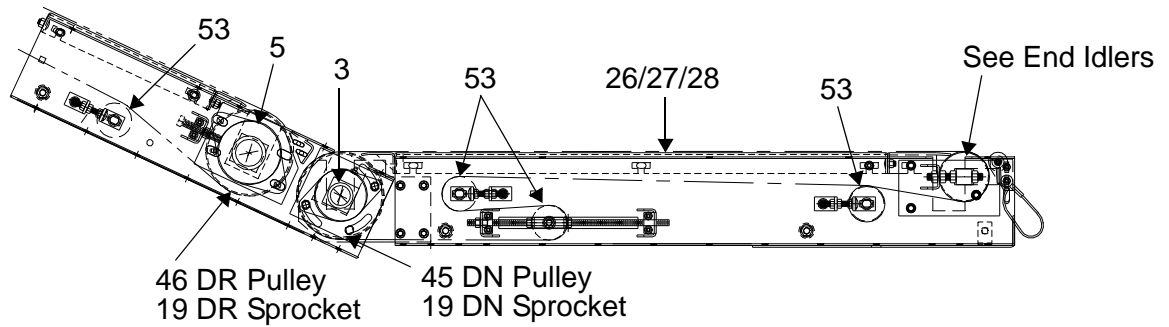

Figure I - 21 Power Feeder - Decline

---

Reversible

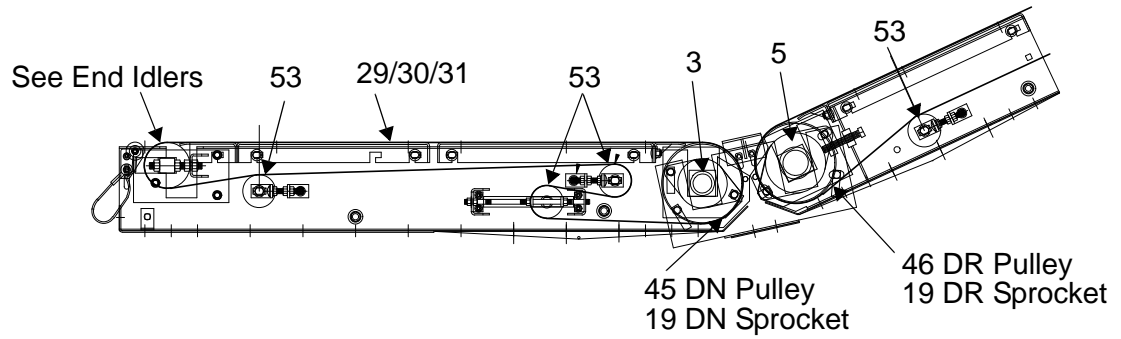

Figure I - 22 Power Feeder - Reversible

## Non-Width Related Parts

Key No.	Part Description	Part Number
1	Air Cylinder	27-2832
2	Bearing, 2-Bolt Flange, 1-3/16" BR - Pressure Lubricated	40-0985
3	Bearing, 2-Bolt Flange, 1-7/16" BR - Pressure Lubricated	40-0987
4	Bearing, 2-Bolt Flange, 1-11/16" BR - Pressure Lubricated	40-0990
4A	Bearing, 2-Bolt Flange, 1-11/16" BR - Pressure Lubricated (SA2000)	7522411
4B	Bearing, Pillow Block, 1-11/16" BR - Pressure Lubricated (SA2001)	7712387
5	Bearing, 2-Bolt Flange, 1-15/16" BR - Pressure Lubricated	40-0995
6	Bearing, 4-Bolt Flange, 1-15/16" BR - Pressure Lubricated	40-0970
7	Bearing, Take-Up, 1-15/16" BR (5/16" Wide Slot)	70-0145
8	Bearing, Take-Up, 1-15/16" BR (11/16" Wide Slot)	70-0161
8A	Bearing, Take-Up, 1-7/16" BR	40-1150
9	Bearing - For 3-1/2" Idler/Take-Up Pulley (1-1/8" SQ BR)	35-0360
	Bearing - For 3-1/2" Idler/Take-Up Pulley (1-1/16" HX BR)	7220706
10	Chain - RC-50	20-0970
	Chain - RC-50 Connector Link	20-0040
	Chain - RC-60 (High-Speed)	20-0987
	Chain - RC-60 Connector Link	20-0986
	Chain - RC-80 (High Speed)	20-0989
	Chain - RC-80 Connector Link	20-0070
	Chain - RC-100 (High Speed)	20-1000
	Chain - RC-100 Connector Link	20-0080
10A	Timing Belt - Pitch / Width / Length	
	8mm / 21mm / 1200mm	7001504
	8mm / 21mm / 1280mm	7001506
	8mm / 36mm / 1200mm	7001512
	8mm / 36mm / 1280mm	7001514
	14mm / 37mm / 1400mm	7001519
11	Cable - Safety / Fill Roller	50-0843
12	Filter Regulator	27-1241
13	Spring - Extension	31-1000

Key No.	Part Description	Part Number			
	C-Face Motor	Baldor		Reliance	
		Motor	Brake Motor	Motor	Brake Motor
15	208-230/460V-3PH-60HZ - Standard Efficiency				
	1/2HP 56C	7155562	7742489	7001600	7001631
	3/4HP 56C	7150592	7150962	7001601	7704084
	1HP 56C	7745139	7716179	7001602	7172635
	1-1/2HP 145C	7778225	7716197	7001603	7001511
	2 HP 145TC	7274611	7325286	7001604	7704091
	3 HP 182TC	7747525	7747295	7001605	7704708
	5 HP 184TC	7747294	7817618	7001606	7001612
	7-1/2 HP 213TC	7329946	7005792	7001607	7001613
	208-230/460V-3PH-60HZ - Premium Efficiency				
	1/2HP 56C	7002040	7002030	7830000	7001621
	3/4HP 56C	7002041	7002031	7001615	7001622
	1HP 56C	7002042	7002032	7888089	7001623
	1-1/2HP 145C	7002043	7002033	7001632	7001625
	2 HP 145TC	7002044	7002034	7001617	7001626
	3 HP 182TC	7002045	7002035	7001633	7001627
	5 HP 184TC	7002046	7002036	7001618	7001628
	7-1/2 HP 213TC	7002047	7002037	7001619	7001629
	575V-3PH-60HZ - Standard Efficiency				
	1/2HP 56C	7717583	-	7002088	-
	3/4HP 56C	7717584	7152666	7002089	7002090
	1HP 56C	7717598	7717586	-	7002091
	1-1/2HP 145C	7331614	-	-	-
	2 HP 145TC	7763322	-	-	-
	3 HP 182TC	7362599	-	-	-
	5 HP 184TC	7866559	-	-	-
	7-1/2 HP 213TC	7005793	-	-	-
	575V-3PH-60HZ - Premium Efficiency				
	1/2HP 56C	7002050	7002060	7001621	7002092
	3/4HP 56C	7002051	7002061	7001622	7002093
	1HP 56C	7002052	7002062	7001623	7002094
	1-1/2HP 145C	7002053	7002063	7001625	7002095
	2 HP 145TC	7002054	7002064	7001626	7002096
	3 HP 182TC	7002055	7002065	7001627	7002097
	5 HP 184TC	7002056	7002066	7001628	7002098
	7-1/2 HP 213TC	7002057	7002067	7001629	7002099

Key No.	Item		Part Number			
	C-Face Reducer					
			Assembly			
			Series 400, 600, 800 RU-LS		Series 400, 600, 800 LU-RS	
			SA2000 - Shown (RH)		SA2000 - OPP (LH)	
			SA2001 - OPP (LH)		SA2001 - Shown (RH)	
	Reducer		Grove	Reliance	Grove	Reliance
Reducer Model	Motor Frame	3	L1	2	K1	
16	<b>5:1 Ratio</b>					
	218	56C	7005800		7005801	-
	218	145TC	7005802	-	7005803	-
	220	56C	7005804	-	7005805	-
	220	145TC	7005806	-	7005141	-
	220	184TC	7005807	-	7005808	-
	224	145TC	7005809	-	7005810	-
	224	182TC	7005035	-	7005811	-
	226	56C	7030646	-	7030645	-
	226	145TC	7030649	-	7030648	-
	226	182TC	7005021	-	7030474	-
	226	184TC	7005021	-	7030474	-
	230	184TC	7005039	-	7005812	-
	232	213TC	7005813	-	7005814	-
	175	56C	-	7005899	-	7005900
	175	145TC	-	7005901	-	7005902
	200	56	-	7005920	-	7005921
	200	145TC	-	7005922	-	7005923
	200	182TC	-	7005924	-	7005925
	262	56C	-	7005940	-	7005941
	262	145TC	-	7005942	-	7005943
	262	182TC	-	7005944	-	7005945
	262	184TC	-	7005944	-	7005945
350	184TC	-	7005968	-	7005969	



Key No.	Item		Part Number			
	C-Face Reducer					
			Assembly			
			Series 400, 600, 800 RU-LS		Series 400, 600, 800 LU-RS	
			SA2000 - Shown (RH)		SA2000 - OPP (LH)	
			SA2001 - OPP (LH)		SA2001 - Shown (RH)	
	Reducer		Grove	Reliance	Grove	Reliance
Reducer Model	Motor Frame	3	L1	2	K1	
16	<b>7.5:1 Ratio</b>					
	220	56C	7005815	-	7005025	-
	220	145TC	7005159	-	7005027	-
	224	145TC	7005816	-	7005036	-
	224	182TC	7005817	-	7005818	-
	230	184TC	7005819	-	7005820	-
	232	213TC	7005821	-	7005822	-
	242	213TC	7005823	-	7005824	-
	200	56C	-	7005926	-	7005927
	200	145TC	-	7005928	-	7005929
	262	182TC	-	7005946	-	7005947
	350	182TC	-	N/A	-	N/A
16	<b>10:1 Ratio</b>					
	218	56C	7005825	-	7005826	-
	220	56C	7005223	-	7005312	-
	220	145TC	7005827	-	7005828	-
	224	145TC	7005830	-	7005831	-
	226	56C	7031010	-	7031017	-
	226	145TC	7030471	-	7030470	-
	230	182TC	7005832	-	7005833	-
	232	182TC	7031008	-	7031009	-
	232	184TC	7031008	-	7031009	-
	242	184TC	7005834	-	7005835	-
	242	213TC	7005836	-	7005837	-
	175	56C	-	7005903	-	7005904
	200	56C	-	7005930	-	7005931
	200	145TC	-	7005932	-	7005933
	262	56C	-	7005948	-	7005949
	262	145TC	-	7005950	-	7005951
350	182TC	-	7005972	-	7005973	

Key No.	Item		Part Number			
	C-Face Reducer					
			Assembly			
			Series 400, 600, 800 RU-LS		Series 400, 600, 800 LU-RS	
			SA2000 - Shown (RH)		SA2000 - OPP (LH)	
			SA2001 - OPP (LH)		SA2001 - Shown (RH)	
	Reducer		Grove	Reliance	Grove	Reliance
Reducer Model	Motor Frame	3	L1	2	K1	
16	<b>15:1 Ratio</b>					
	218	56C	7005838	-	7005839	-
	220	56C	7005221	-	7005840	-
	220	145TC	7005033	-	7005841	-
	224	56C	7005037	-	7005158	-
	224	145TC	7005038	-	7005032	-
	226	56C	7031016	-	7031014	-
	226	145TC	7005086	-	7005030	-
	230	182TC	7005142	-	7005731	-
	232	145TC	7005842	-	7005843	-
	232	182TC	7005092	-	7005091	-
	242	184TC	7005844	-	7005845	-
	242	213TC	7005846	-	7005847	-
	175	56C	-	7005905	-	7005906
	200	56C	-	7005934	-	7005935
	262	56C	-	7005952	-	7005953
	262	145TC	-	7005954	-	7005955
	350	145TC	-	7005974	-	7005975
	350	182TC	-	7005976	-	7005977

Key No.	Item		Part Number			
	C-Face Reducer					
			Assembly			
			Series 400, 600, 800 RU-LS		Series 400, 600, 800 LU-RS	
			SA2000 - Shown (RH)		SA2000 - OPP (LH)	
			SA2001 - OPP (LH)		SA2001 - Shown (RH)	
	Reducer		Grove	Reliance	Grove	Reliance
Reducer Model	Motor Frame	3	L1	2	K1	
16	<b>20:1 Ratio</b>					
	218	56C	7005848	-	7005849	-
	220	56C	7005850	-	7005851	-
	224	56C	7005852	-	7005853	-
	224	145TC	7005854	-	7005333	-
	226	56C	7031012	-	7031013	-
	226	145TC	7005081	-	7005080	-
	230	182TC	7005855	-	7005320	-
	232	145TC	7030647	-	7031018	-
	232	182TC	7005090	-	7005089	-
	242	182TC	7005856	-	7005857	-
	242	184TC	7005856	-	7005857	-
	175	56C	-	7005907	-	7005908
	200	56C	-	7005936	-	7005937
	262	56C	-	7005746	-	7005956
	262	145TC	-	7005957	-	7005958
	350	145TC	-	7005978	-	7005979
350	182TC	-	7005980	-	7005981	

Key No.	Item		Part Number			
	C-Face Reducer					
			Assembly			
			Series 400, 600, 800 RU-LS		Series 400, 600, 800 LU-RS	
			SA2000 - Shown (RH)		SA2000 - OPP (LH)	
			SA2001 - OPP (LH)		SA2001 - Shown (RH)	
	Reducer		Grove	Reliance	Grove	Reliance
Reducer Model	Motor Frame	3	L1	2	K1	
16	<b>25:1 Ratio</b>					
	218	56C	7005858	-	7005859	-
	220	56C	7005860	-	7005861	-
	224	56C	7005862	-	7005863	-
	224	145TC	7005864	-	7005865	-
	226	56C	7031015	-	7031011	-
	230	145TC	7005866	-	7005867	-
	232	145TC	7005085	-	7005084	-
	232	182TC	7005088	-	7005087	-
	175	56C	-	7005909	-	7005910
	200	56C	-	7005744	-	7005913
	262	56C	-	7005754	-	7005742
	262	145TC	-	7005959	-	7005960
	350	145TC	-	7005982	-	7005983
	350	182TC	-	7005984	-	7005985
	<b>30:1 Ratio</b>					
	218	56C	7005868	-	7005869	-
	224	56C	7005870	-	7005783	-
	226	56C	7005069	-	7005068	-
	230	56C	7005871	-	7005872	-
	232	145TC	7005083	-	7005082	-
	242	145TC	7005874	-	7005875	-
	242	182TC	7005766	-	7005876	-
	175	56C		7005911		7005912
	200	56C		7005914		7005915
	262	56C		7005961		7005962
	350	145TC		7005986		7005541

Key No.	Item		Part Number			
	C-Face Reducer					
			Assembly			
			Series 400, 600, 800 RU-LS		Series 400, 600, 800 LU-RS	
			SA2000 - Shown (RH)		SA2000 - OPP (LH)	
			SA2001 - OPP (LH)		SA2001 - Shown (RH)	
	Reducer		Grove	Reliance	Grove	Reliance
Reducer Model	Motor Frame	3	L1	2	K1	
16	<b>40:1 Ratio</b>					
	220	56C	7005877	-	7005878	-
	224	56C	7005879	-	7005328	-
	226	56C	7005065	-	7005064	-
	230	56C	7005880	-	7005881	-
	232	145TC	7005075	-	7005074	-
	242	145TC	7005882	-	7005883	-
	242	182TC	7005321	-	7005884	-
	200	56C	-	7005916	-	7005917
	262	56C	-	7005752	-	7005963
	350	145TC	-	7005987	-	7005988
16	<b>50:1 Ratio</b>					
	224	56C	7005885	-	7005886	-
	232	56C	7005887	-	7005888	-
	232	145TC	7005073	-	7005072	-
	242	145TC	7005889	-	7005890	-
	200	56C	-	7005918	-	7005919
	262	56C	-	7005964	-	7005965
	350	56C	-	7005989	-	7005990
350	145TC	-	7005991	-	7005992	

Key No.	Item		Part Number			
	C-Face Reducer					
			Assembly			
			Series 400, 600, 800 RU-LS		Series 400, 600, 800 LU-RS	
			SA2000 - Shown (RH)		SA2000 - OPP (LH)	
			SA2001 - OPP (LH)		SA2001 - Shown (RH)	
	Reducer		Grove	Reliance	Grove	Reliance
Reducer Model	Motor Frame	3	L1	2	K1	
16	<b>60:1 Ratio</b>					
	220	56C	7005891	-	7005892	-
	224	56C	7005893	-	7005894	-
	226	56C	7005061	-	7005060	-
	230	56C	7005895	-	7005896	-
	232	56C	7005067	-	7005066	-
	232	145TC	7005071	-	7005070	-
	242	145TC	7005897	-	7005898	-
	200	56C	-	7005938	-	7005939
	262	56C	-	7005966	-	7005967
	350	56C	-	7005993	-	7005994
	350	145TC	-	7005995	-	7005996

Key No.	Item		Part Number					
	Chain Sprocket (Power Unit - Driver)							
	Size - Teeth - Belt Width	Sprocket Hub Type (TL Bushing No.)	Reducer Output Shaft Diameter					
.875			1.000	1.125	1.250	1.500	1.875	
17	Series 400 / 600 / 800 - End Drive							
	RC50 - 11T	Type B Hub	745505					
	RC50 - 13T	Type B Hub	745513	745512	745510			
	RC50 - 14T	Type B Hub			745514			
	RC50 - 17T	Type B Hub			745517			
	RC60 - 9T	Type B Hub	745100					
	RC60 - 10T	Type B Hub	745101		745102			
	RC60 - 11T (TL Bushing)	Type B Hub	745111	745110	745112			
		Type TL Hub (1008)	745631		745631			
	RC60 - 13T (TL Bushing)	Type B Hub			745133			
		Type TL Hub (1210)	745633	745633	745633			
	RC60 - 14T (TL Bushing)	Type B Hub			745142		745144	
		Type TL Hub (1210)	745634	745634	745634		745634	
	RC60 - 15T (TL Bushing)	Type TL Hub (1610)	745635	745635	745635		745635	
			230746	230747	230748		230753	
	RC60 - 16T (TL Bushing)	Type B Hub					745165	
		Type TL Hub (1610)					745636	
	RC60 - 17T (TL Bushing)	Type B Hub					230753	
		Type TL Hub (1610)			745637		745637	
	RC60 - 18T (TL Bushing)	Type TL Hub (1610)			230748		230753	
			745638	745638	745638		745638	
RC60 - 19T (TL Bushing)	Type TL Hub (1610)			230748		230753		
		745639	745639	745639		745639		
RC60 - 20T (TL Bushing)	Type TL Hub (2012)					745640		
						230785		
RC60 - 21T (TL Bushing)	Type TL Hub (2012)					745641		
						230785		

Key No.	Item		Part Number					
	Chain Sprocket (Power Unit - Driver)							
	Size - Teeth - Belt Width	Sprocket Hub Type (TL Bushing No.)	Reducer Output Shaft Diameter					
.875			1.000	1.125	1.250	1.500	1.875	
17	RC60 - 22T (TL Bushing)	Type TL Hub (2012)		745642	745642		745642	
				230777	230778		230785	
	RC60 - 25T (TL Bushing)	Type TL Hub (1008)????					745645	
	RC60 - 26T (TL Bushing)	Type TL Hub (1210)					745646	
	RC60 - 29T (TL Bushing)	Type TL Hub (1610)					745649	
							230753	
	RC60 - 30T (TL Bushing)	Type TL Hub (1610)					745650	
							230753	
	RC80 - 11T	Type B Hub					745313	
	RC80 - 12T	Type B Hub					745322	
	(TL Bushing)	Type TL Hub (1615)					745683	
							230766	
	RC80 - 13T	Type B Hub					745333	
	(TL Bushing)	Type TL Hub (1615)					745684	
							230766	
	RC80 - 14T	Type B Hub					745342	
	(TL Bushing)	Type TL Hub (1615)					745685	
							230766	
	RC80 - 16T	Type B Hub					745360	
	(TL Bushing)	Type TL Hub (2012)						745687
							230786	
RC80 - 17T	Type B Hub						745372	
(TL Bushing)	Type TL Hub (2012)						745688	
							230786	
RC80 - 18T	Type TL Hub						745689	
(TL Bushing)	(2012)						230786	
RC80 - 19T	Type TL Hub						745690	
(TL Bushing)	(2012)						230786	
RC80 - 20T	Type TL Hub						745691	
(TL Bushing)	(2517)						230798	
RC80 - 21T	Type TL Hub						745692	
(TL Bushing)	(2517)						230798	
RC80 - 23T	Type TL Hub						745694	
(TL Bushing)	(2517)						230798	



Key No.	Item		Part Number						
	Chain Sprocket (Power Unit - Driver)								
	Size - Teeth - Belt Width	Sprocket Hub Type (TL Bushing No.)	Reducer Output Shaft Diameter						
.875			1.000	1.125	1.250	1.500	1.875		
17	RC100 - 10T	Type B Hub						745500	
	RC100 - 11T	Type B Hub						745432	
		Type TL Hub						745718	
		(SDS)						230759	
	RC100 - 12T	Type B Hub						745440	
		Type TL Hub						745719	
		(SDS)						230759	
	RC100 - 13T	Type TL Hub						745723	
		(2012)						230786	
	RC100 - 14T	Type TL Hub						745758	
		(2517)						230798	
	SA2000 / 2001 - Intermediate / Low-Profile Drive								
	RC60 - 16T (TL Bushing)	Type TL Hub (1610)		7788120	7788120	7788120	7788120		
				7115210	7115213	7115223	7115228		
	RC60 - 19T (TL Bushing)	Type TL Hub (1610)		7742721	7742721	7742721	7742721		
				7115210	7115213	7115223	7115228		
	RC60 - 20T (TL Bushing)	Type TL Hub (2012)		7743918	7743918	7743918	7743918		
				7115235	7115228	7115227	7721059		
	RC60 - 21T (TL Bushing)	Type TL Hub (2012)		7120512	7120512	7120512	7120512	7120512	
				7115235	7115228	7115227	7721059	7115234	
RC60 - 22T (TL Bushing)	Type TL Hub (2012)		7000092	7000092	7000092	7000092			
			7115235	7115228	7115227	7721059			
RC60 - 23T (TL Bushing)	Type TL Hub (2012)		7125294	7125294	7125294	7125294			
			7115235	7115228	7115227	7721059			
RC60 - 25T (TL Bushing)	Type TL Hub (2012)		7730801	7730801	7730801	7730801	7730801		
			7115235	7115228	7115227	7721059	7115234		

Key No.	Item		Part Number					
	Chain Sprocket (Power Unit - Driver)							
	Size - Teeth - Belt Width	Sprocket Hub Type (TL Bushing No.)	Reducer Output Shaft Diameter					
.875			1.000	1.125	1.250	1.500	1.875	
17A	Timing-Belt Sprocket (Power Unit - Driver)							
	8mm-30T-21 (TL Bushing)	Type TL Hub (1108)		7001533				
				7001513				
	8mm-32T-21 (TL Bushing)	Type TL Hub (1210)		7001534	7001534			
				7200560	7115208			
	8mm-32T-36 (TL Bushing)	Type TL Hub (1210)				7001551		
						7115207		
	8mm-34T-21 (TL Bushing)	Type TL Hub (1610)		7001535	7001535	7001535		
				7115210	7115213	7115223		
	8mm-34T-36 (TL Bushing)	Type TL Hub (1210)				7001552		
						7115207		
	8mm-36T-21 (TL Bushing)	Type TL Hub (1610)		7001536	7001536			
				7115210	7115213			
	8mm-36T-36 (TL Bushing)	Type TL Hub (1610)			7001553			
					7115213			
	8mm-38T-21 (TL Bushing)	Type TL Hub (1610)		7001537	7001537	7001537		
				7115210	7115213	7115223		
	8mm-38T-36 (TL Bushing)	Type TL Hub (1610)			7001554	7001554	7001554	
					7115213	7115223	7732428	
	8mm-40T-21 (TL Bushing)	Type TL Hub (2012)		7001538	7001538	7001538		
				7115235	7115228	7115227		
	8mm-40T-36 (TL Bushing)	Type TL Hub (2012)				7001555		7001555
						7115227		7115234
	8mm-42T-21 (TL Bushing)	Type TL Hub (2012)		7001539	7001539	7001539		
				7115235	7115228	7115227		
	8mm-42T-36 (TL Bushing)	Type TL Hub (2012)			7001556			
					7115228			
	8mm-45T-21 (TL Bushing)	Type TL Hub (2012)		7001540	7001540	7001540		
			7115235	7115228	7115227			
8mm-48T-21 (TL Bushing)	Type TL Hub (2012)		7001541	7001541	7001541			
			7115235	7115228	7115227			
8mm-48T-36 (TL Bushing)	Type TL Hub (2012)				7001558			
					7115227			
8mm-50T-21 (TL Bushing)	Type TL Hub (2012)		7001542	7001542	7001542			
			7115235	7115228	7115227			

Key No.	Item		Part Number					
	Chain Sprocket (Power Unit - Driver)							
	Size - Teeth - Belt Width	Sprocket Hub Type (TL Bushing No.)	Reducer Output Shaft Diameter					
.875			1.000	1.125	1.250	1.500	1.875	
17A	14mm-28T-37 (TL Bushing)	Type TL Hub (2012)					7001566	7001566
							7721059	7115234
	14mm-30T-37 (TL Bushing)	Type TL Hub (2517)				7001568	7001568	7001568
						7001524	775668	7174980
	14mm-32T-37 (TL Bushing)	Type TL Hub (2517)					7001570	7001570
							7756668	7174980
	14mm-34T-37 (TL Bushing)	Type TL Hub (2517)					7001572	7001572
							7756668	7174980
	14mm-36T-37 (TL Bushing)	Type TL Hub (2517)					7001574	7001574
							7756668	7174980
	14mm-40T-37 (TL Bushing)	Type TL Hub (3020)				7001578		
						7001527		

Key No.	Item	Part Number			
18	Chain Sprocket (Pulley Driven)				
	Size - Teeth - Belt Width	Sprocket Hub Type (TL Bushing No.)	<b>Reducer Output Shaft Diameter</b>		
			1.187"	1.427"	1.675"
	Series 400, 600, and 800 - End Drive				
	RC50 - 13T	Type B Hub	745511		
	RC60 - 21T  (TL Bushing)	Type B Hub		745207	
		Type TL Hub (2012)		745641	
				230781	
	RC60 - 27T  (TL Bushing)	Type B Hub			745270
		Type TL Hub (2012)			745647
					230782
	RC80 - 15T  (TL Bushing)	Type B Hub		745350	
		Type TL Hub (1615)		745686	
				230769	
	RC80 - 19T  (TL Bushing)	Type B Hub			745392
		Type TL Hub (2012)			745690
					230782
	RC100 - 15T  (TL Bushing)	Type TL Hub			745725
		(2517)			230793
	SA2000 / 2001 - Intermediate / Low Profile				
RC60 - 26T  (TL Bushing)	Type TL Hub			7717361	
	(2012)			7115238	
RC60 - 32T  (TL Bushing)	Type TL Hub			7742328	
	(2012)			7115238	

Key No.	Item	Part Number			
18A	Timing-Belt Sprocket (Pulley - Driven)				
	8mm-71T-21 (TL Bushing)	Type TL Hub (2517)			7001548
					7115239
	8mm-71T-36 (TL Bushing)	Type TL Hub (2517)			7001563
					7115239
	8mm-75T-21 (TL Bushing)	Type TL Hub (2517)			7001549
					7115239
	8mm-75T-36 (TL Bushing)	Type TL Hub (2517)			7001564
					7115239
	8mm-80T-21 (TL Bushing)	Type TL Hub (2517)			7001550
					7115239
	8mm-80T-36 (TL Bushing)	Type TL Hub (3020)			7001565
				7000084	
14mm-50T-37 (TL Bushing)	Type TL Hub (3020)			7001582	
				7000084	
14mm-53T-37 (TL Bushing)	Type TL Hub (3020)			7001583	
				7000084	
14mm-56T-37 (TL Bushing)	Type TL Hub (3525)			7001584	
				7000085	
19	Chain Sprocket (Power Feeder, Jackknife Pulley - Driver / Driven)				
	RC50 - 15T (H Bushing)	Type H Hub		745551	
				239510	
	RC50 - 17T (TL Bushing)	Type TL Hub (1610)		1225017	
				230950	
	RC50 - 19T (TL Bushing)	Type TL Hub (1610)		1225019	
				230950	
	RC50 - 21T (TL Bushing)	Type TL Hub (1610)		1225021	
			230950		
RC50 - 23T (TL Bushing)	Type TL Hub (2012)		1225023		
			230981		
Note: "B" = Sprocket with finished bore. "TL" = Sprocket with taper-bore bushing. "H" = Sprocket with split taper bushing.					

## Width Related Parts

Key No.	Part Description	Part Number				
		16"	22"	28"	34"	40"
		Note: Belt Width = Conveyor Width MINUS 4".				
21	Belt - Horizontal Conveyor (Specify Footage Required)					
	PVC 100 Brushed x FS (Black)	19-0355	19-0491	19-0550	19-0582	19-0595
22	Belt - Incline/Decline Conveyor (Specify Footage Required)					
	PVC 100 RT x FS (Black)	19-0360	19-0492	19-0580	19-0583	19-0594
23	Belt - Inclined Power Feeder - FS x FS (Cut to Length; No Lacing/Pin)					
	3'-0" lg. Power Feeder (91" lg.)	19-0266	19-0272			
	4'-0" lg. Power Feeder (116" lg.)	19-0185	19-0192	19-0198		
	7'-0" lg. Power Feeder (188" lg.)				19-0204	19-0210
24	Belt - Inclined Power Feeder - RT x FS (Cut to Length; No Lacing/Pin)					
	3'-0" lg. Power Feeder (91" lg.)	19-0267	19-0273			
	4'-0" lg. Power Feeder (116" lg.)	19-0186	19-0193	19-0199		
	7'-0" lg. Power Feeder (188" lg.)				19-0205	19-0211
25	Belt - Declined Power Feeder - FS x FS (Cut to Length; No Lacing/Pin)					
	3'-0" lg. Power Feeder (104" lg.)	19-0373	19-0375			
	4'-0" lg. Power Feeder (131" lg.)	19-0377	19-0379	19-0381		
	7'-0" lg. Power Feeder (203" lg.)				19-0383	19-0385
26	Belt - Decline Power Feeder - RT x FS (Cut to Length; No Lacing/Pin)					
	3'-0" lg. Power Feeder (104" lg.)	19-0374	19-0376			
	4'-0" lg. Power Feeder (131" lg.)	19-0378	19-0380	19-0382		
	7'-0" lg. Power Feeder (203" lg.)				19-0384	19-0386
27	Belt - Reversible Power Feeder - FS x FS (Cut to Length; No Lacing/Pin)					
	4'-0" lg. Power Feeder (124" lg.)	19-0235	19-0242	19-0248		
	7'-0" lg. Power Feeder (196" lg.)				19-0254	19-0260
28	Belt - Reversible Power Feeder - RT x FS (Cut to Length; No Lacing/Pin)					
	4'-0" lg. Power Feeder (124" lg.)	19-0236	19-0243	19-0249		
	7'-0" lg. Power Feeder (196" lg.)				19-0255	19-0261

Key No.	Part Description	Part Number				
		16"	22"	28"	34"	40"
32	Belt Lacing - Clipper (Quantity Required)					
	No. 1A, 6" lg. (FS x FS)	19-0701(4)	19-0701(6)	19-0701(8)	19-0701(10)	19-0701(12)
	No. 1, 6" lg. (RT x FS)	19-0702(4)	19-0702(6)	19-0702(8)	19-0702(10)	19-0702(12)
	Belt Lacing Pin - Clipper					
	No. 25 (for No. 1/1A Lacing)	19-0709(1)	19-0709(1.5)	19-0709(2)	19-0709(2.5)	19-0709(3)
33	Belt Lacing with Pin - Alligator					
	No. 7 (FS x FS)	19-0880	19-0892	19-0894	19-0896	19-0898
	No. 15 (RT x FS)	19-0966	19-0968	19-0970	19-0980	19-0990
34	Pulley/Shaft, Drive, Crown Face, Lagged, Single Shaft Extension (Power Unit)					
	Series 400 - 4-3/16" x 1-3/16"	48-53016	48-53022	48-53028	58-53034	48-53040
	Series 600 - 6-3/16" x 1-7/16"	48-52416	48-52422	48-52428	48-52434	48-52440
	Series 800 - 8-3/16" x 1-11/16"	48-52716	48-52722	48-52728	48-52734	48-52740
34A	Pulley w/Shaft, Drive, Crown Face, Lagged (SA2000 Intermediate Drive)					
	8-1/4" dia., 1-11/16" Shaft	7005177	7005179	7005008	7005181	7005183
34B	Pulley w/Shaft, Drive, Crown Face, Lagged (SA2001 Low Profile Intermediate Drive)					
	6-1/4" dia., 1-11/16" Shaft	7005289	7005291	7005004	7005293	7005295
35	Pulley/Shaft, Drive, Crown-Face, Lagged, Double Shaft Extension (Power Unit w/PTO)					
	Series 600 - 6-3/16" x 1-7/16"	48-52516	48-58522	48-52528	48-52534	48-52450
	Series 800 - 8-3/16" x 1-11/16"	48-52316	48-52322	48-52328	48-52334	48-52340
37	Pulley/Shaft, Idler, Crown-Face, Lagged, Single Shaft Extension (Idler w/PTO)					
	6" x 1-15/16" (Stepped to 1-7/16")	68-1468	68-1469	68-1470	68-1472	68-1473
38	Pulley/Axle, Idler, Crown-Face (End Idler)					
	3-1/2" x 1-1/8" SQ BR	50-1243	50-1244	50-1245	50-1246	50-1250
	Axle - 1-1/8" SQ (End Idler Assy.)	69-0909	69-0910	69-0919	69-0920	69-0970
39	Pulley/Axle, Take-Up, Crown-Face (Series 600/800) End Dr - Jackknife/Power Feeder					
	3-1/2" x 1-1/8" SQ BR	50-1243	50-1244	50-1245	50-1246	50-1250
	Axle - 1-1/8" SQ CRS	69-0942	69-0943	69-0944	69-0945	69-0946
40	Pulley/Axle, Idler, Flat Face, (Series 600/800) End Dr - Jackknife/Power Feeder					
	3-1/2" x 1-1/8" SQ BR	50-1238	50-1239	50-1240	50-1241	50-1247
	Axle - 1-1/8" SQ CRS	69-0942	69-0943	69-0944	69-0945	69-0946
40A	Pulley & Axle, Take-Up, Crown Face, (SA2000 / 2001 Intermediate / Low Profile)					
	3-1/2" x 1-1/16" HX BR	7005184	7005188	7005009	7005186	7005187
	Axle - 1-1/16" CRS Hex	7005188	7005189	7005010	7005190	7005191

Key No.	Part Description	Part Number				
		16"	22"	28"	34"	40"
42	Pulley/Shaft, Take-Up - Crown Faced, No Shaft Extension - Auxiliary TU					
	6" x 1-15/16"	48-52616	48-52622	48-52628	48-52634	48-52640
42A	Pulley/Shaft, Take-Up - Crown Faced, No Shaft Extension - Auxiliary Spring TU					
	5.5" x 1-7/16"	68-5036	68-5037	68-5038	68-5039	68-5040
43	Pulley/Shaft, Idler - Flat Faced, No Shaft Extension - Auxiliary TU					
	6" x 1-7/16"	48-52916	48-52922	48-52928	48-52934	48-52940
43A	Pulley/Shaft, Idler - Flat Faced, No Shaft Extension - Auxiliary Spring TU					
	5.5" x 1-5/16"	68-5026	68-5027	68-5028	68-5029	68-5030
44	Pulley - Idler Knife Edge					
	2-1/4" x 3/4" BR	51-0001	51-0002	51-0003	51-0004	51-0005
45	Pulley/Shaft, Driven (DN) Power Feeder, Crown-Face, Lagged, Single Shaft Ext.					
	Incl./Decl/Rev PF 6-3/16" x 1-7/16"	68-3251	68-3252	68-3253	68-3254	68-3255
46	Pulley/Shaft, Driver (DR) - Power Feeder, Crown-Face, Lagged, Single Shaft Ext.					
	Inclined PF 6-3/16" x 1-7/16"	68-3251	68-3252	68-3253	68-3254	68-3255
	Decl/Rev PF 6-3/16" x 1-15/16"	68-3256	68-3257	68-3258	68-3259	68-3260
47	Pulley/Shaft, Driver (DR) - Powered Jackknife, Crown-Face, Double Shaft Ext.					
	Incline JK 6-3/16" x 1-7/16"	4852516	4852522	4852528	4852534	4852540
48	Pulley/Shaft, Driven (DN) - Powered Jackknife, Crown-Face, Lagged, Single Shaft Ext.					
	Incline JK 6-3/16" x 1-7/16"	4852416	4852422	4852428	4852434	4852440
49	Pulley/Shaft Driver (DR) - Non-Powered Jackknife, Crown-Face, Lagged, Single Shaft Ext.					
	Decline JK 6-3/16" x 1-15/16"	68-1468	68-1469	68-1470	68-1472	68-1473
50	Pulley/Shaft Drive (DN) - Non-Powered Jackknife, Crown-Face, Lagged, Single Ext. Shaft					
	Decline JK 6-3/16" x 1-7/16"	4852416	4852422	4852428	4852434	4852440



Key No.	Part Description	Conveyor Width "W" Part Number				
		16"	22"	28"	34"	40"
51*	Roller/Shaft - Carrier/Belt Return (Roller BED - BCR, and Slide Bed - BCS)					
	RLR G196 GH P 01 __-__ NC	7017540	7017541	7017542	7017543	7017544
	RLR G196 A1 P 01 __-__ NC	7015687	7015688	7015689	7015690	7015691
51A*	Roller/Shaft - Belt Return (Box-Bed - BCB)					
	RLR G196 GH P 01 15.81 NC	7496328	-	-	-	-
	RLR G196 GH P 01 21.81 NC	-	7496429	-	-	-
	RLR G196 GH P 01 27.81 NC	-	-	7496521	-	-
	RLR G196 GH P 01 33.81 NC	-	-	-	7496600	-
	RLR G196 GH P 01 39.81 NC	-	-	-	-	7496655
	RLR G196 A1 P 01 15.81 NC	7491816	-	-	-	-
	RLR G196 A1 P 01 21.81 NC	-	7491817	-	-	-
	RLR G196 A1 P 01 27.81 NC	-	-	7491818	-	-
	RLR G196 A1 P 01 33.81 NC	-	-	-	7491819	-
52	Roller and Axle - Fill					
	No. G131P (1-5/16" x 3/8" HX BR)	501095	501096	501097	501098	501099
53	Roller/Shaft - Snub/Take-Up					
	No. G251AB 2-1/2" x 11/16" HX BR	501056	501057	501058	501059	501060
54	Roller - Adjustable / Fixed Snub SA2000 and SA2001					
	2-9/16" x 11/16 HX BR	7005192	7005193	7005011	7005194	7005195
54A	Shaft - Adjustable Snub SA2001					
	11/16' CRS Hex	7005196	7005197	7005012	7005198	7005199
54B	Shaft - Fixed Snub SA2001					
	11/16' CRS Hex	7005296	7005297	7005045	7005298	7005299

(\*) Roller Description Explanation

(Example) RLR G 196 GH P 01 16.00 NC

NC = No Cover  
 16.00 = Conveyor Width "W"  
 01 = Spring-Loaded Axle; Fixed Roller w/o Grooves  
 P = Plain Steel Axle  
 A1 = (Bearing Type) ABEC Precision Bearing  
 GH = (Bearing Type) Greased, Commercial Bearing  
 196 = (Roller Tube) 1.90" dia x 16 gage (.065" wall)  
 G = (Roller Tube Material/Finish) Galvanized Steel  
 RLR = Roller

---

## Lubricants and Paints

Part Description	Part Number
Reducer Lubricant	
Groove / Reliance Reducer, +20° F (1) Gallon	Consult Factory
Grove / Reliance Reducer, -20° to +20° F (1) Gallon	Consult Factory
Paint	
FKI Logistex Satin Gray - Spray Can	7900005

**SECTION J: PRODUCT INDEX**

**Roller Bed**

**Belt Conveyors - Power Feeders, Incline, and Decline**

**ITEMCLASS**

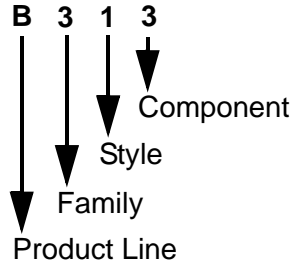

- (F1) BC FEEDER UNIT ASSY 6" PULLEY
- (F2) BC 3.5" or KNIFE EDGE IDLER
- (F3) SNUB ROLLERS

- (F4) SPEED RATIO-GUARD and BACKPLATE
- (F5) BC PF BELT and LACING

DESCRIPTION	Dwg. No.	16W	22W	28W	34W	40W
BC PF RB&SB INCLINE 3-0/_	19393D	825481	825482			
BC PF RB&SB INCLINE 4-0/_	19393D	825483	825484	825485		
BC PF RB&SB INCLINE 7-0/_	19393D				825486	825487
BC PF RB&SB DECLINE 3-0/_	19394D	825488	825489			
BC PF RB&SB DECLINE 4-0/_	19394D	825490	825491	825492		
BC PF RB&SB DECLINE 7-0/_	19394D				825493	825494
BC PF RB&SB REVERSE 4-0/_	19293D	823091	823092	823093		
BC PF RB&SB REVERSE 7-0/_	19293D				823094	823095

BC = BELT CONVEYOR  
PF = POWER FEEDER

RB = ROLLER BED  
SB = SLIDER BED

**Belt Conveyors - Upper Bend**

**ITEM CLASS B 3 1 6**

- (F1) UB PARTS 1.9 or 2.5
- (F2) UB BED ROLLER 1.9/2.5

- (F3) UB G251AB SNUB

DESCRIPTION	Dwg. No.	16W	22W	28W	34W	40W
BC, UB, RB, and SB 10 to 30° W__	19294D	823096	823097	823098	823099	823100

BC = BELT CONVEYOR  
UB = UPPER BEND

RB = ROLLER BED  
SB = SLIDER BED

## Belt Conveyors - Jackknife Non-Drive Units

### ITEM CLASS B 3 1 5

(F1) BC JACKKNIFE UNIT ASSY 6" PULLEY (F3) SPEED RATIO-GUARD and BACKPLATE  
 (F2) SNUB ROLLERS

DESCRIPTION	Dwg. No.	16W	22W	28W	34W	40W
BC JK NON-DRN 2-0/___TU @ PIVOT	19295D	823101	823102	823103	823104	823105
BC JK NON-DRN 3-0/___TU at FIXED	19091D	823941	823942	823943	823944	823945

BC = BELT CONVEYOR  
 JK = JACKKNIFE

NON-DRN = NON-DRIVEN  
 TU = TAKE-UP

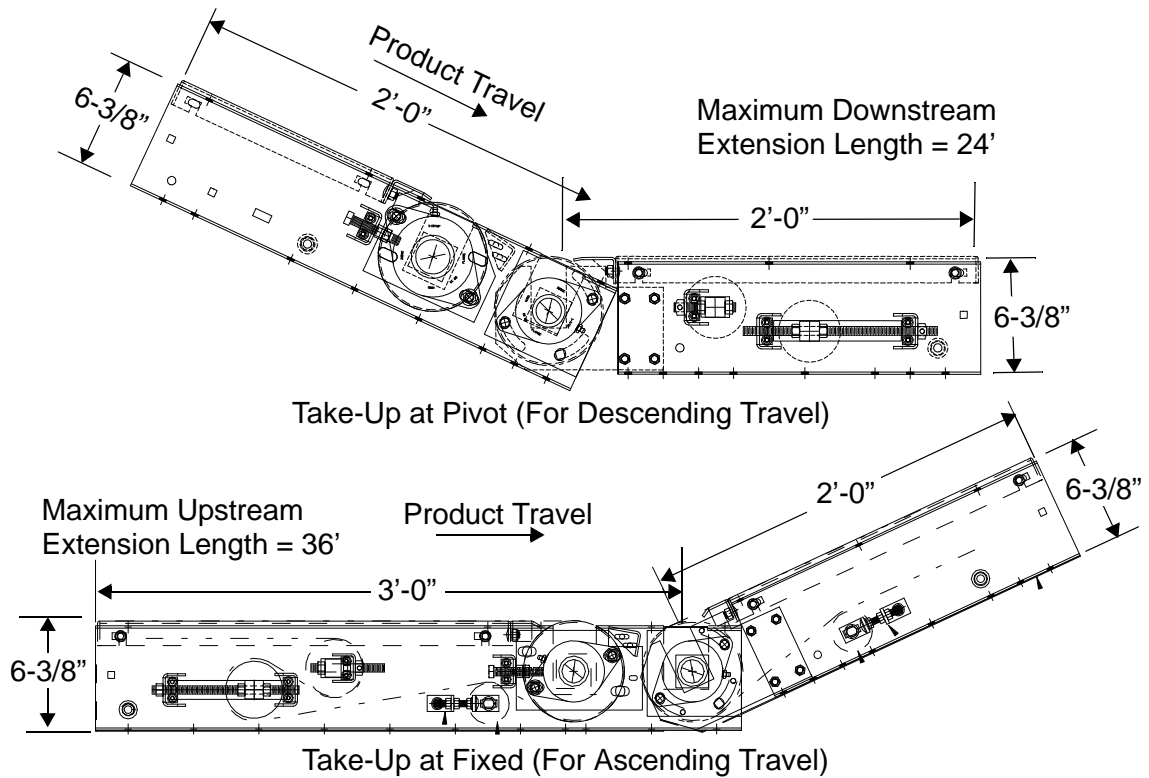

Figure J - 1 Jackknife Non-Drive Units

## Belt Conveyors - Roller Bed, Idler Units

### ITEM CLASS B 3 1 2

(F1) BC 3.5", 6" or KNIFE EDGE IDLER  
(F2) BC IU CHAN RAIL RB

(F3) BED and RETURN ROLLERS  
(F4) SNUB ROLLER

DESCRIPTION	Dwg. No.	16W	22W	28W	34W	40W
BC IU RB 3"CTR 3-0/___	19197D	823106	823107	823108	823109	823110
BC IU RB 6"CTR 3-0/___	19197D	823111	823112	823113	823114	823115
BC IU RB 9"CTR 3-0/___	19197D	823116	823117	823118	823119	823120
BC IU RB 3"CTR 6-0/___	19197D	823121	823122	823123	823124	823125
BC IU RB 6"CTR 6-0/___	19197D	823126	823127	823128	823129	823130
BC IU RB 9"CTR 6-0/___	19197D	823131	823132	823133	823134	823135
BC IU RB 3"CTR 9-0/___	19197D	823136	823137	823138	823139	823140
BC IU RB 6"CTR 9-0/___	19197D	823141	823142	823143	823144	823145
BC IU RB 9"CTR 9-0/___	19197D	823146	823147	823148	823149	823150
BC IU RB 3"CTR 12-0/___	19197D	823151	823152	823153	823154	823155
BC IU RB 6"CTR 12-0/___	19197D	823156	823157	823158	823159	823160
BC IU RB 9"CTR 12-0/___	19197D	823161	823162	823163	823164	823165

BC = BELT CONVEYOR  
RB = ROLLER BED

IU = IDLER UNIT

## Belt Conveyors - Idler With Upper Bend

### ITEM CLASS B 3 1 2

(F1) BC 3.5", 6" or KNIFE EGDE IDLER  
 (F2) BC UB PARTS 1.9 or 2.5

(F3) BC UB BED ROLLER 1.9/2.5  
 (F4) BC IU/UB G251AB SNUB

DESCRIPTION	Dwg. No.	16W	22W	28W	34W	40W
BC IU w/UB RB&SB 2-0/___	19297D	823166	823167	823168	823169	823170

BC = BELT CONVEYOR  
 RB = ROLLER BED  
 SB = SLIDER BED

U = IDLER UNIT  
 UB = UPPER BEND

## Belt Conveyors - Roller Bed, Intermediate

### ITEM CLASS B 3 1 4

(F1) BC IS CHAN RAIL RB

(F2) BED and RETURN ROLLERS

DESCRIPTION	Dwg. No.	16W	22W	28W	34W	40W
BC IS RB 3"CTR 3-0/___	19266D	823066	823067	823068	823069	823070
BC IS RB 6"CTR 3-0/___	19266D	823071	823072	823073	823074	823075
BC IS RB 9"CTR 3-0/___	19266D	823076	823077	823078	823079	823080
BC IS RB 3"CTR 6-0/___	19266D	823001	823002	823003	823004	823005
BC IS RB 6"CTR 6-0/___	19266D	823006	823007	823008	823009	823010
BC IS RB 9"CTR 6-0/___	19266D	823011	823012	823013	823014	823015
BC IS RB 3"CTR 9-0/___	19266D	823016	823017	823018	823019	823020
BC IS RB 6"CTR 9-0/___	19266D	823021	823022	823023	823024	823025
BC IS RB 9"CTR 9-0/___	19266D	823026	823027	823028	823029	823030
BC IS RB 3"CTR 12-0/___	19266D	823031	823032	823033	823034	823035
BC IS RB 6"CTR 12-0/___	19266D	823036	823037	823038	823039	823040
BC IS RB 9"CTR 12-0/___	19266D	823041	823042	823043	823044	823045

BC = BELT CONVEYOR  
 RB = ROLLER BED

IS = INTERMEDIATE SECTION

## Belt Conveyors - Roller Bed, Center Take-up Units

### ITEM CLASS B 3 1 3

(F1) BC IS CHAN RAIL RB 12-0  
(F2) BED ROLLERS

(F3) SNUB ROLLER  
(F4) BC CENTER TAKE-UP UNIT

DESCRIPTION	Dwg. No.	16W	22W	28W	34W	40W
BC CT RB 3CTR 3.5 SCREW 12-0/___	19298D	823191	823192	823193	823194	823195
BC CT RB 6CTR 3.5 SCREW 12-0/___	19298D	823196	823197	823198	823199	823200
BC CT RB 9CTR 3.5 SCREW 12-0/___	19298D	823201	823202	823203	823204	823205
BC CT RB 3CTR 6" SCREW 12-0/___	19299D	823206	823207	823208	823209	823210
BC CT RB 6CTR 6" SCREW 12-0/___	19299D	823211	823212	823213	823214	823215
BC CT RB 9CTR 6" SCREW 12-0/___	19299D	823216	823217	823218	823219	823220
BC CT RB 3CTR 6" AIR 12-0/___	19300D	823221	823222	823223	823224	823225
BC CT RB 6CTR 6" AIR 12-0/___	19300D	823226	823227	823228	823229	823230
BC CT RB 9CTR 6" AIR 12-0/___	19300D	823231	823232	823233	823234	823235

(F1) BC IS CHAN RAIL RB 12-0  
(F2) BED ROLLERS

(F3) SPRING TAKE-UP

DESCRIPTION	Dwg. No.	16W	22W	28W	34W	40W
BC CT RB 3C SPRING-TU 12-0/	18969D	823995	823996	823997	823998	823999
BC CT RB 6C SPRING-TU 12-0/	18969D	824000	824001	824002	824003	824004
BC CT RB 9C SPRING-TU 12-0/	18969D	824005	824006	824007	824008	824009

BC = BELT CONVEYOR  
RB = ROLLER BED  
CT= CENTER TAKE-UP

3.5 = 3.5" Dia. SCREW TAKE-UP PULLEY  
6 = 6" Dia. SCREW TAKE-UP PULLEY  
AIR = 6" Dia. AIR TAKE-UP PULLEY

## Belt Conveyors - Roller Bed, End Drive Units

### ITEM CLASS B 3 1 1

- |                             |                                   |
|-----------------------------|-----------------------------------|
| (F1) BC END DRIVE UNIT      | (F5) POWER UNIT RH                |
| (F2) BC IS CHAN RAIL RB 4-0 | (F6) POWER UNIT LH                |
| (F3) BED and RETURN ROLLERS | (F7) MOTOR                        |
| (F4) SNUB ROLLER            | (F8) BC EDRV CHAIN GUARD and SUPT |

DESCRIPTION	Dwg. No.	16W	22W	28W	34W	40W
BC ED RB 04 3CTR 6-0/	19301D	824492	824493	824494		
BC ED RB 04 6CTR 6-0/	19301D	824495	824496	824497		
BC ED RB 04 9CTR 6-0/	19301D	824498	824499	824500		
BC ED RB 06 3CTR 6-0/	19302D	824501	824502	824503	824504	824505
BC ED RB 06 6CTR 6-0/	19302D	824506	824507	824508	824509	824510
BC ED RB 06 9CTR 6-0/	19302D	824511	824512	824513	824514	824515
BC ED RB 08 3CTR 6-0/	19302D	824516	824517	824518	824519	824520
BC ED RB 08 6CTR 6-0/	19302D	824521	824522	824523	824524	824525
BC ED RB 08 9CTR 6-0/	19302D	824526	824527	824528	824529	824530

- |                    |                                       |
|--------------------|---------------------------------------|
| BC = BELT CONVEYOR | 04 = 400 SERIES - 4-5/16" Dia. PULLEY |
| RB = ROLLER BED    | 06 = 600 SERIES - 6-5/16" Dia. PULLEY |
| ED = END DRIVE     | 08 = 800 SERIES - 8-5/16" Dia. PULLEY |

## Belt Conveyors - End Drive With Upper Bend

### ITEM CLASS B 3 1 1

- |                               |                                   |
|-------------------------------|-----------------------------------|
| (F1) BC END DRIVE UNIT        | (F5) POWER UNIT RH                |
| (F2) BC UB PARTS 1.9 or 2.5   | (F6) POWER UNIT LH                |
| (F3) BC UB BED ROLLER 1.9/2.5 | (F7) MOTOR                        |
| (F4) BC DU/UB G251AB SNUB     | (F8) BC EDRV CHAIN GUARD and SUPT |

DESCRIPTION	Dwg. No.	16W	22W	28W	34W	40W
BC ED w/UB RB&SB 04 2-0/___	19304D	824531	824532	824533		
BC ED w/UB RB&SB 06 2-0/___	19304D	824536	824537	824538	824539	824540
BC ED w/UB RB&SB 08 2-0/___	19304D	824541	824542	824543	824544	824545

- |                    |                                       |
|--------------------|---------------------------------------|
| BC = BELT CONVEYOR | 04 = 400 SERIES - 4-5/16" Dia. PULLEY |
| UB = UPPER BEND    | 06 = 600 SERIES - 6-5/16" Dia. PULLEY |
| ED = END DRIVE     | 08 = 800 SERIES - 8-5/16" Dia. PULLEY |



**Belt Conveyors - Roller Bed, End Drive With Jackknife**

**ITEM CLASS B 3 1 1**

(F1) BC END DRIVE w/JACKKNIFE UNIT  
 (F2) BC IS CHAN RAIL RB 4-0  
 (F3) BED and RETURN ROLLERS  
 (F4) SNUB ROLLER  
 (F5) POWER UNIT RH

(F6) POWER UNIT LH  
 (F7) MOTOR  
 (F8) BC EDRV CHAIN GUARD and SUPT  
 (F9) SPEED RATIO-GUARD and BACKPLATE

DESCRIPTION	Dwg. No.	16W	22W	28W	34W	40W
BC ED-JK RB 06 3CTR 7-0/___	19307D	824546	824547	824548	824549	824550
BC ED-JK RB 06 6CTR 7-0/___	19307D	824551	824552	824553	824554	824555
BC ED-JK RB 06 9CTR 7-0/___	19307D	824556	824557	824558	824559	824560

BC = BELT CONVEYOR  
 RB = ROLLER BED  
 ED = END DRIVE

JK = JACKKNIFE  
 06 = 600 SERIES - 6-5/16" Dia. PULLEY

## Belt Conveyors - Roller Bed, SA2000 - Intermediate Drive

### ITEM CLASS B 3 1 1

#### How To Order

An SA2000 Intermediate Drive is ordered by entering a Call-Up line which includes the “Required Fields” to define the drive and “Options Fields” to define the options to be supplied.

**Call-Up Line Format** - State the Call-Up in the order shown below and in Table J 1 and Table J 2.

SA2000 - W - SPEED - HP - REDUCER/MOTOR - VOLTAGE - OPTIONS

#### Example - SA2000 Intermediate Drive Application

SA2000 Intermediate Drive - 22” “W” - Nominal Belt Speed of 60 fpm - 1 HP - Grove Reducer and Baldor Motor - 230-460VAC, 3 PH, 60HZ - Timing Belt Drive.

#### Example Call-Up Line - SA2000-22-60-1-GB-V1-TB

**Call-Up Required Fields** - Table J 1 lists the Required Fields in the order to be stated in the Call-Up.

Table J 1: Required Call-Up Fields

Field	Description	Call-Up Entry
“W” (Select 1 Only)	Between Frame	16, 22, 28, 34, or 40
SPEED (Select 1 Only)	Speed (fpm) for Chain Drive	30, 45, 60, 75, 90, 105, 120, 135, 150, 165, or 180
	Speed (fpm) for Timing Belt Drive	30, 45, 60, 75, 90, 105, 120, 135, 150, 165, 180, 200, 225, 250, 275, 300, 325, 350, 375, 400, 425, 450, 475, or 500
HP (Select 1 Only)	Horsepower for Chain Drive	.5, .7, 1, 1.5, 2, or 3
	Horsepower for Timing Belt Drive	.5, .7, 1, 1.5, 2, 3, 5, or 7.5
REDUCER/ MOTOR (Select 1 Only)	Grove/Baldor	GB
	Grove/Reliance	GR
	Dodge (TiGear)/Reliance	DR
	Dodge (TiGear)/Baldor	DB
VOLTAGE (Select 1 Only)	208-230/460 VAC, 3 PH, 60 HZ	V1
	575 VAC, 3 PH, 60 HZ	V2
	115 VAC, 1 PH, 60 HZ	V3

**Call-Up Option Fields** - Table J 2 lists the Option Fields in the order to be stated in the Call-Up.

Table J 2: Option Call-Up Fields

Option Description	Call-Up Entry
For Opposite Hand Unit	OPP
Brake Motor with Brake Coil Wired into Motor	B1
Brake Motor with 115 Volt Brake Coil Wired Seperate from Motor (with “PE” option only)	B2
Timing Belt Drive	TB
Premium Efficient Motor	PE
Clutch - Brake (56 Double C-Face with 90 Volt Coil)	CB
Clutch - Brake Power Supply (Required on all standard orders with “CB” option)	PS

**Belt Conveyors - Roller Bed, SA2001 - Intermediate Drive - Low Profile**

**ITEM CLASS B 3 1 1**

**How To Order**

An SA2001 Intermediate Drive is ordered by entering a Call-Up line which includes the “Required Fields” to define the drive and “Options Fields” to define the options to be supplied.

**Call-Up Line Format** - State the Call-Up in the order shown below and in Table J 3 and Table J 4.

SA2001 - W - SPEED - HP - REDUCER/MOTOR - VOLTAGE - OPTIONS

**Example - SA2001 Intermediate Drive Application**

SA2001 Intermediate Drive - Low Profile - 22” “W” - Nominal Belt Speed of 60 fpm - 1 HP - Grove Reducer and Baldor Motor - 230-460VAC, 3 PH, 60HZ - Timing Belt Drive.

**Example Call-Up Line** - SA2001-22-60-1-GB-V1-TB

**Call-Up Required Fields** - Table J 3 lists the Required Fields in the order to be stated in the Call-Up.

Table J 3: Required Call-Up Fields

Field	Description	Call-Up Entry
“W” (Select 1 Only)	Between Frame	16, 22, 28, 34, or 40
SPEED (Select 1 Only)	Speed (fpm) for Chain Drive	30, 45, 60, 75, 90, 105, 120, 135, 150, 165, or 180
	Speed (fpm) for Timing Belt Drive	30, 45, 60, 75, 90, 105, 120, 135, 150, 165, 180, 200, 225, 250, 275, 300, 325, 350, 375, 400, 425, 450, 475, or 500
HP (Select 1 Only)	Horsepower for Chain Drive	.5, .7, 1, 1.5, 2, or 3
	Horsepower for Timing Belt Drive	.5, .7, 1, 1.5, 2, 3, 5, or 7.5
REDUCER/ MOTOR (Select 1 Only)	Grove/Baldor	GB
	Grove/Reliance	GR
	Dodge (TiGear)/Reliance	DR
	Dodge (TiGear)/Baldor	DB
VOLTAGE (Select 1 Only)	208-230/460 VAC, 3 PH, 60 HZ	V1
	575 VAC, 3 PH, 60 HZ	V2
	115 VAC, 1 PH, 60 HZ	V3

**Call-Up Option Fields** - Table J 4 lists the Option Fields in the order to be stated in the Call-Up.

Table J 4: Option Call-Up Fields

Option Description	Call-Up Entry
For Opposite Hand Unit	OPP
Brake Motor with Brake Coil Wired into Motor	B1
Brake Motor with 115 Volt Brake Coil Wired Seperate from Motor (with “PE” option only)	B2
Timing Belt Drive	TB
Premium Efficient Motor	PE
Clutch - Brake (56 Double C-Face with 90 Volt Coil)	CB
Clutch - Brake Power Supply (Required on all standard orders with “CB” option)	PS

## Belt Conveyors - Roller Bed, Complete End Drive 400

### ITEM CLASS B 3 1 1

- |                             |                                      |
|-----------------------------|--------------------------------------|
| (F1) BC END DRIVE UNIT      | (F6) POWER UNIT LH                   |
| (F2) BC IU CHAN RAIL RB     | (F7) MOTOR                           |
| (F3) BED and RETURN ROLLERS | (F8) BC EDRV CHAIN GUARD and SUPT    |
| (F4) SNUB ROLLERS           | (F9) BC 3.5", 6" or KNIFE EDGE IDLER |
| (F5) POWER UNIT RH          | (F10) BC EDU BELT and LACING         |

DESCRIPTION	Dwg. No.	16W	22W	28W	34W	40W
BC EDU RB 04 6CTR 5-0/_ OALG	19072D	824741	824742	824743	824744	824745
BC EDU RB 04 6CTR 6-0/_ OALG	19072D	824746	824747	824748	824749	824750
BC EDU RB 04 6CTR 7-0/_ OALG	19072D	824751	824752	824753	824754	824755
BC EDU RB 04 6CTR 8-0/_ OALG	19072D	824756	824757	824758	824759	824760
BC EDU RB 04 6CTR11-0/_ OALG	19072D	824761	824762	824763	824764	824765
BC EDU RB 04 6CTR12-0/_ OALG	19072D	824766	824767	824768	824769	824770
BC EDU RB 04 6CTR14-0/_ OALG	19072D	824771	824772	824773	824774	824775

BC = BELT CONVEYOR	EDU = END DRIVE UNIT - COMPLETE
RB = ROLLER BED	04 = 400 SERIES - 4-5/16" Dia. PULLEY

## Belt Conveyors - Roller Bed, Complete End Drive 600

### ITEM CLASS B 3 1 1

- |                             |                                      |
|-----------------------------|--------------------------------------|
| (F1) BC END DRIVE UNIT      | (F6) POWER UNIT LH                   |
| (F2) BC IU CHAN RAIL RB     | (F7) MOTOR                           |
| (F3) BED and RETURN ROLLERS | (F8) BC EDRV CHAIN GUARD and SUPT    |
| (F4) SNUB ROLLERS           | (F9) BC 3.5", 6" or KNIFE EDGE IDLER |
| (F5) POWER UNIT RH          | (F10) BC EDU BELT and LACING         |

DESCRIPTION	Dwg. No.	16W	22W	28W	34W	40W
BC EDU RB 06 6CTR 5-0/_ OALG	19073D	824776	824777	824778	824779	824780
BC EDU RB 06 6CTR 6-0/_ OALG	19073D	824781	824782	824783	824784	824785
BC EDU RB 06 6CTR 7-0/_ OALG	19073D	824786	824787	824788	824789	824790
BC EDU RB 06 6CTR 8-0/_ OALG	19073D	824791	824792	824793	824794	824795
BC EDU RB 06 6CTR11-0/_ OALG	19073D	824796	824797	824798	824799	824800
BC EDU RB 06 6CTR12-0/_ OALG	19073D	824801	824802	824803	824804	824805
BC EDU RB 06 6CTR14-0/_ OALG	19073D	824806	824807	824808	824809	824810

BC = BELT CONVEYOR	EDU = END DRIVE UNIT - COMPLETE
RB = ROLLER BED	06 = 600 SERIES - 6-5/16" Dia. PULLEY

---

## Belt Conveyors - Roller Bed, Complete End Drive 800

### ITEM CLASS B 3 1 1

(F1) BC END DRIVE UNIT  
 (F2) BC IU CHAN RAIL RB  
 (F3) BED and RETURN ROLLERS  
 (F4) SNUB ROLLERS  
 (F5) POWER UNIT RH

(F6) POWER UNIT LH  
 (F7) MOTOR  
 (F8) BC EDRV CHAIN GUARD and SUPT  
 (F9) BC 3.5", 6" or KNIFE EDGE IDLER  
 (F10) BC EDU BELT and LACING

DESCRIPTION	Dwg. No.	16W	22W	28W	34W	40W
BC EDU RB 08 6CTR 5-0/_ OALG	19073D	824811	824812	824813	824814	824815
BC EDU RB 08 6CTR 6-0/_ OALG	19073D	824816	824817	824818	824819	824820
BC EDU RB 08 6CTR 7-0/_ OALG	19073D	824821	824822	824823	824824	824825
BC EDU RB 08 6CTR 8-0/_ OALG	19073D	824826	824827	824828	824829	824830
BC EDU RB 08 6CTR11-0/_ OALG	19073D	824831	824832	824833	824834	824835
BC EDU RB 08 6CTR12-0/_ OALG	19073D	824836	824837	824838	824839	824840
BC EDU RB 08 6CTR14-0/_ OALG	19073D	824841	824842	824843	824844	824845

BC = BELT CONVEYOR  
 RB = ROLLER BED

EDU = END DRIVE UNIT - COMPLETE  
 08 = 800 SERIES - 8-5/16" Dia. PULLEY

## Belt Conveyors - Roller Bed, Complete Center Drive 600

### ITEM CLASS B 3 1 1

- |                              |                                      |
|------------------------------|--------------------------------------|
| (F1) BC CENTER DRIVE UNIT    | (F6) POWER UNIT LH                   |
| (F2) BC CDU-IDL CHAN RAIL RB | (F7) MOTOR                           |
| (F3) BED and RETURN ROLLERS  | (F8) BC CD CHAIN GUARD and SUPT      |
| (F4) SNUB ROLLERS            | (F9) BC 3.5", 6" or KNIFE EDGE IDLER |
| (F5) POWER UNIT RH           | (F10) BC CD BELT and LACING          |

DESCRIPTION	Dwg. No.	16W	22W	28W	34W	40W
<b>DECLINE</b>						
BC CDU RB06 3CTR DECL 9-0/___	19209D	824846	824847	824848	824849	824850
BC CDU RB06 6CTR DECL 9-0/___	19209D	824851	824852	824853	824854	824855
BC CDU RB06 9CTR DECL 9-0/___	19209D	824856	824857	824858	824859	824860
BC CDU RB06 3CTR DECL 12-0/___	19209D	824861	824862	824863	824864	824865
BC CDU RB06 6CTR DECL 12-0/___	19209D	824866	824867	824868	824869	824870
BC CDU RB06 9CTR DECL 12-0/___	19209D	824871	824872	824873	824874	824875
<b>INCLINE</b>						
BC CDU RB06 3CTR INCL 9-0/___	19210D	824876	824877	824878	824879	824880
BC CDU RB06 6CTR INCL 9-0/___	19210D	824881	824882	824883	824884	824885
BC CDU RB06 9CTR INCL 9-0/___	19210D	824886	824887	824888	824889	824890
BC CDU RB06 3CTR INCL 12-0/___	19210D	824891	824892	824893	824894	824895
BC CDU RB06 6CTR INCL 12-0/___	19210D	824896	824897	824898	824899	824900
BC CDU RB06 9CTR INCL 12-0/___	19210D	824901	824902	824903	824904	824905

DECL = USE ON DECLINE and HORIZONTAL RB = ROLLER BED  
 INCL = USE ON INCLINE CDU = CENTER DRIVE UNIT - COMPLETE  
 BC = BELT CONVEYOR  
 06 = 600 SERIES - 6-5/16" Dia. PULLEY w/3.5" Dia. TAKE-UP ROLLER

## Belt Conveyors - Roller Bed, Complete Center Drive 800

### ITEM CLASS B 3 1 1

(F1) BC CENTER DRIVE UNIT  
 (F2) BC CDU-IDL CHAN RAIL RB  
 (F3) BED and RETURN ROLLERS  
 (F4) SNUB ROLLERS  
 (F5) POWER UNIT RH

(F6) POWER UNIT LH  
 (F7) MOTOR  
 (F8) BC CD CHAIN GUARD and SUPT  
 (F9) BC 3.5", 6" or KNIFE EDGE IDLER  
 (F10) BC CD BELT and LACING

DESCRIPTION	Dwg. No.	16W	22W	28W	34W	40W
DECLINE						
BC CDU RB08 3CTR DECL 9-0/___	19209D	824906	824907	824908	824909	824910
BC CDU RB08 6CTR DECL 9-0/___	19209D	824911	824912	824913	824914	824915
BC CDU RB08 9CTR DECL 9-0/___	19209D	824916	824917	824918	824919	824920
BC CDU RB08 3CTR DECL 12-0/___	19209D	824921	824922	824923	824924	824925
BC CDU RB08 6CTR DECL 12-0/___	19209D	824926	824927	824928	824929	824930
BC CDU RB08 9CTR DECL 12-0/___	19209D	824931	824932	824933	824934	824935
INCLINE						
BC CDU RB08 3CTR INCL 9-0/___	19210D	824936	824937	824938	824939	824940
BC CDU RB08 6CTR INCL 9-0/___	19210D	824941	824942	824943	824944	824945
BC CDU RB08 9CTR INCL 9-0/___	19210D	824946	824947	824948	824949	824950
BC CDU RB08 3CTR INCL 12-0/___	19210D	824951	824952	824953	824954	824955
BC CDU RB08 6CTR INCL 12-0/___	19210D	824956	824957	824958	824959	824960
BC CDU RB08 9CTR INCL 12-0/___	19210D	824961	824962	824963	824964	824965

DECL = USE ON DECLINE and HORIZONTAL RB = ROLLER BED  
 INCL = USE ON INCLINE BC = BELT CONVEYOR  
 CDU = CENTER DRIVE UNIT - COMPLETE  
 08 = 800 SERIES - 8-5/16" Dia. PULLEY w/3.5" Dia. TAKE-UP ROLLER

## Slider Bed

### Belt Conveyors - Power Feeders, Incline and Decline

**ITEM CLASS B 3 1 5**

(F1) BC FEEDER UNIT ASSY 6" PULLEY  
 (F2) BC 3.5" or KNIFE EDGE IDLER  
 (F3) SNUB ROLLERS

(F4) SPEED RATIO-GUARD and BACKPLATE  
 (F5) BC PF BELT and LACING

DESCRIPTION	Dwg. No.	16W	22W	28W	34W	40W
BC PF RB&SB INCLINE 4-0/___	19393D	825483	825484	825485		
BC PF RB&SB INCLINE 7-0/___	19393D				825486	825487
BC PF RB&SB DECLINE 4-0/___	19394D	825490	825491	825492		
BC PF RB&SB DECLINE 7-0/___	19394D				825493	825494
BC PF RB&SB REVERSE 4-0/___	19293D	823091	823092	823093		
BC PF RB&SB REVERSE 7-0/___	19293D				823094	823095
BC PF RB&SB INCLINE 3-0/___	19393D	825481	825482			
BC PF RB&SB DECLINE 3-0/___	19394D	825488	825489			

BC = BELT CONVEYOR  
 PF = POWER FEEDER

RB = ROLLER BED  
 SB = SLIDER BED

### Belt Conveyors - Upper Bend

**ITEM CLASS B 3 1 6**

(F1) UB PARTS 1.9 or 2.5  
 (F2) UB BED ROLLER 1.9/2.5

(F3) UB G251AB SNUB

DESCRIPTION	Dwg. No.	16W	22W	28W	34W	40W
BC UB RB&SB 10 TO 30DEG W___	19294D	823096	823097	823098	823099	823100

BC = BELT CONVEYOR  
 UB = UPPER BEND

RB = ROLLER BED  
 SB = SLIDER BED



**Belt Conveyors - Jackknife Non-Driven Units**

**ITEM CLASS B 3 1 5**

(F1) BC JACKKNIFE UNIT ASSY 6" PULLEY (F3) SPEED RATIO-GUARD and BACKPLATE  
 (F2) SNUB ROLLERS

DESCRIPTION	Dwg. No.	16W	22W	28W	34W	40W
BC JK NON-DRN 2-0/_TU @ PIVOT	19295D	823101	823102	823103	823104	823105
BC JK NON-DRN 3-0/_TU @ FIXED	19091D	823941	823942	823943	823944	823945

BC = BELT CONVEYOR  
 JK = JACKKNIFE

NON-DRN = NON-DRIVEN  
 TU = TAKE-UP

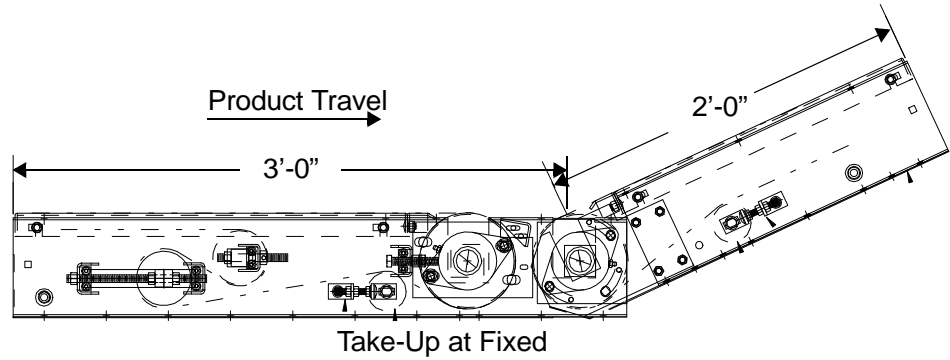
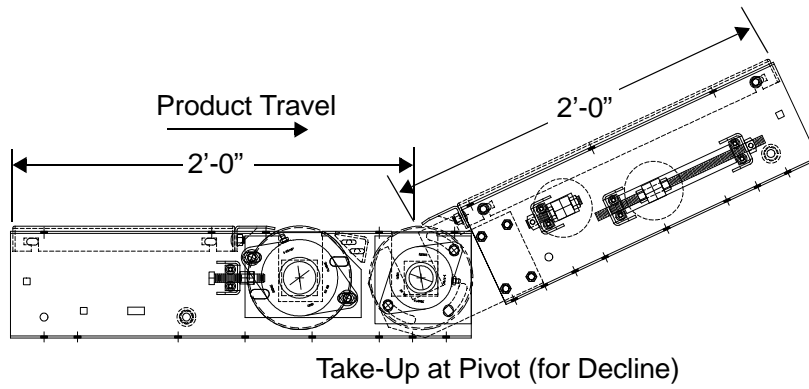

Figure J - 2 Jackknife Non-Drive Units

## Belt Conveyors - Slider Bed, Idler Units

### ITEM CLASS B 3 2 2

(F1) BC 3.5", 6" or KNIFE EDGE IDLER  
 (F2) BC IU CHAN RAIL SB and PANS

(F3) RETURN ROLLERS  
 (F4) SNUB ROLLER

DESCRIPTION	Dwg. No.	16W	22W	28W	34W	40W
BC IU SB 3-0/___	19197D	823171	823172	823173	823174	823175
BC IU SB 6-0/___	19197D	823176	823177	823178	823179	823180
BC IU SB 9-0/___	19197D	823181	823182	823183	823184	823185
BC IU SB 12-0/___	19197D	823186	823187	823188	823189	823190

BC = BELT CONVEYOR  
 SB = SLIDER BED

IU = IDLER UNIT

## Belt Conveyors - Idler With Upper Bend

### ITEM CLASS B 3 1 2

(F1) BC 3.5", 6" or KNIFE EDGE IDLER  
 (F2) BC UB PARTS 1.9 or 2.5

(F3) BC UB BED ROLLER 1.9/2.5  
 (F4) BC IU/UB G251AB SNUB

DESCRIPTION	Dwg. No.	16W	22W	28W	34W	40W
BC IU w/UB RB&SB 2-0/___	19297D	823166	823167	823168	823169	823170

BC = BELT CONVEYOR  
 RB = ROLLER BED  
 SB = SLIDER BED

IU = IDLER UNIT  
 UB = UPPER UNIT

## Belt Conveyors - Slider Bed, Intermediate

### ITEM CLASS B 3 2 4

(F1) BC IS CHAN RAIL SB and PANS

(F2) RETURN ROLLERS

DESCRIPTION	Dwg. No.	16W	22W	28W	34W	40W
BC IS SB 3-0/___	19266D	823061	823062	823063	823064	823065
BC IS SB 6-0/___	19266D	823046	823047	823048	823049	823050
BC IS SB 9-0/___	19266D	823051	823052	823053	823054	823055
BC IS SB 12-0/___	19266D	823056	823057	823058	823059	823060

BC = BELT CONVEYOR  
 SB = SLIDER BED

IS = INTERMEDIATE SECTION

## Belt Conveyors - Slider Bed, Center Take-up Units

### ITEM CLASS B 3 2 3

(F1) BC IS SB RAIL and PANS 12-0  
(F2) NON-REQUIRED

(F3) SNUB ROLLER  
(F4) BC CENTER TAKE-UP UNIT

DESCRIPTION	Dwg. No.	16W	22W	28W	34W	40W
BC CT SB 3.5" SCREW-TU 12-0/___	19298D	823236	823237	823238	823239	823240
BC CT SB 6" SCREW-TU 12-0/___	19299D	823241	823242	823243	823244	823245
BC CT SB 6" AIR-TU 12-0/___	19300D	823246	823247	823248	823249	823250

(F1) BC IS SB RAIL and PANS 12-0  
(F2) RETURN ROLLER

(F3) SPRING TAKE-UP

DESCRIPTION	Dwg. No.	16W	22W	28W	34W	40W
BC CT SB SPRING-TU 12-0/	18969D	823990	823991	823992	823993	823994

BC = BELT CONVEYOR  
SB = SLIDER BED  
CT = CENTER TAKE-UP

3.5 = 3.5" Dia. SCREW TAKE-UP PULLEY  
6 = 6" Dia. SCREW TAKE-UP PULLEY  
AIR = 6" Dia. AIR TAKE-UP PULLEY

## Belt Conveyors - Slider Bed, End Drive Units

### ITEM CLASS B 3 2 1

(F1) BC END DRIVE UNIT  
(F2) BC IS SB RAIL and PANS 4-0  
(F3) RETURN ROLLER  
(F4) SNUB ROLLER

(F5) POWER UNIT RH  
(F6) POWER UNIT LH  
(F7) MOTOR  
(F8) BC EDRV CHAIN GUARD and SUPT

DESCRIPTION	Dwg. No.	16W	22W	28W	34W	40W
BC ED SB 04 6-0/___	19301D	824971	824972	824973		
BC ED SB 06 6-0/___	19302D	824976	824977	824978	824979	824980
BC ED SB 08 6-0/___	19302D	824981	824982	824983	824984	824985

BC = BELT CONVEYOR  
SB = SLIDER BED  
ED = END DRIVE

04 = 400 SERIES - 4-5/16" Dia. PULLEY  
06 = 600 SERIES - 6-5/16" Dia. PULLEY  
08 = 800 SERIES - 8-5/16" Dia. PULLEY

## Belt Conveyors - End Drive With Upper Bend

### ITEM CLASS B 3 1 1

- |                               |                                   |
|-------------------------------|-----------------------------------|
| (F1) BC END DRIVE UNIT        | (F5) POWER UNIT RH                |
| (F2) BC UB PARTS 1.9 or 2.5   | (F6) POWER UNIT LH                |
| (F3) BC UB BED ROLLER 1.9/2.5 | (F7) MOTOR                        |
| (F4) BC DU/UB G251AB SNUB     | (F8) BC EDRV CHAIN GUARD and SUPT |

DESCRIPTION	Dwg. No.	16W	22W	28W	34W	40W
BC ED w/UB RB&SB 04 2-0/___	19304D	824531	824532	824533		
BC ED w/UB RB&SB 06 2-0/___	19304D	824536	824537	824538	824539	824540
BC ED w/UB RB&SB 08 2-0/___	19304D	824541	824542	824543	824544	824545

BC = BELT CONVEYOR	04 = 400 SERIES - 4-5/16" Dia. PULLEY
UB = UPPER BEND	06 = 600 SERIES - 6-5/16" Dia. PULLEY
ED = END DRIVE	08 = 800 SERIES - 8-5/16" Dia. PULLEY

## Belt Conveyors - Slider Bed, End Drive with Jackknife

### ITEM CLASS B 3 2 1

- |                                    |                                      |
|------------------------------------|--------------------------------------|
| (F1) BC END DRIVE w/JACKKNIFE UNIT | (F6) POWER UNIT LH                   |
| (F2) BC IS SB RAIL and PANS 4-0    | (F7) MOTOR                           |
| (F3) RETURN ROLLER                 | (F8) BC EDRV CHAIN GUARD and SUPT    |
| (F4) SNUB ROLLER                   | (F9) SPEED RATIO-GUARD and BACKPLATE |
| (F5) POWER UNIT RH                 |                                      |

DESCRIPTION	Dwg. No.	16W	22W	28W	34W	40W
BC ED-JK 06 SB 7-0/___	19307D	824966	824967	824968	824969	824970

BC = BELT CONVEYOR	JK = JACKKNIFE
SB = SLIDER BED	06 = 600 SERIES - 6-5/16" Dia. PULLEY
ED = END DRIVE	

## Belt Conveyors - Slider Bed, SA2000 - Intermediate Drive

### ITEM CLASS B 3 2 1

#### How To Order

An SA2000 Intermediate Drive is ordered by entering a Call-Up line which includes the "Required Fields" to define the drive and "Options Fields" to define the options to be supplied.

**Call-Up Line Format** - State the Call-Up in the order shown below and in Table J 5 and Table J 6.

SA2000 - W - SPEED - HP - REDUCER/MOTOR - VOLTAGE - OPTIONS

#### Example - SA2000 Intermediate Drive Application

SA2000 Intermediate Drive - 22" "W" - Nominal Belt Speed of 60 fpm - 1 HP - Grove Reducer and Baldor Motor - 230-460VAC, 3 PH, 60HZ - Timing Belt Drive.

**Example Call-Up Line** - SA2000-22-60-1-GB-V1-TB

**Call-Up Required Fields** - Table J 5 lists the Required Fields in the order to be stated in the Call-Up.

Table J 5: Required Call-Up Fields

Field	Description	Call-Up Entry
"W" (Select 1 Only)	Between Frame	16, 22, 28, 34, or 40
SPEED (Select 1 Only)	Speed (fpm) for Chain Drive	30, 45, 60, 75, 90, 105, 120, 135, 150, 165, or 180
	Speed (fpm) for Timing Belt Drive	30, 45, 60, 75, 90, 105, 120, 135, 150, 165, 180, 200, 225, 250, 275, 300, 325, 350, 375, 400, 425, 450, 475, or 500
HP (Select 1 Only)	Horsepower for Chain Drive	.5, .7, 1, 1.5, 2, or 3
	Horsepower for Timing Belt Drive	.5, .7, 1, 1.5, 2, 3, 5, or 7.5
REDUCER/ MOTOR (Select 1 Only)	Grove/Baldor	GB
	Grove/Reliance	GR
	Dodge (TiGear)/Reliance	DR
	Dodge (TiGear)/Baldor	DB
VOLTAGE (Select 1 Only)	208-230/460 VAC, 3 PH, 60 HZ	V1
	575 VAC, 3 PH, 60 HZ	V2
	115 VAC, 1 PH, 60 HZ	V3

**Call-Up Option Fields** - Table J 6 lists the Option Fields in the order to be stated in the Call-Up.

Table J 6: Option Call-Up Fields

Option Description	Call-Up Entry
For Opposite Hand Unit	OPP
Brake Motor with Brake Coil Wired into Motor	B1
Brake Motor with 115 Volt Brake Coil Wired Separate from Motor (with "PE" option only)	B2
Timing Belt Drive	TB
Premium Efficient Motor	PE
Clutch - Brake (56 Double C-Face with 90 Volt Coil)	CB
Clutch - Brake Power Supply (Required on all standard orders with "CB" option)	PS

## Belt Conveyors - Slider Bed, SA2001 - Intermediate Drive - Low Profile

### ITEM CLASS B 3 2 1

#### How To Order

An SA2001 Intermediate Drive is ordered by entering a Call-Up line which includes the “Required Fields” to define the drive and “Options Fields” to define the options to be supplied.

**Call-Up Line Format** - State the Call-Up in the order shown below and in Table J 7 and Table J 8.

SA2001 - W - SPEED - HP - REDUCER/MOTOR - VOLTAGE - OPTIONS

#### Example - SA2001 Intermediate Drive Application

SA2001 Intermediate Drive - Low Profile - 22” “W” - Nominal Belt Speed of 60 fpm - 1 HP - Grove Reducer and Baldor Motor - 230-460VAC, 3 PH, 60HZ - Timing Belt Drive.

**Example Call-Up Line** - SA2001-22-60-1-GB-V1-TB

**Call-Up Required Fields** - Table J 7 lists the Required Fields in the order to be stated in the Call-Up.

Table J 7: Required Call-Up Fields

Field	Description	Call-Up Entry
“W” (Select 1 Only)	Between Frame	16, 22, 28, 34, or 40
SPEED (Select 1 Only)	Speed (fpm) for Chain Drive	30, 45, 60, 75, 90, 105, 120, 135, 150, 165, or 180
	Speed (fpm) for Timing Belt Drive	30, 45, 60, 75, 90, 105, 120, 135, 150, 165, 180, 200, 225, 250, 275, 300, 325, 350, 375, 400, 425, 450, 475, or 500
HP (Select 1 Only)	Horsepower for Chain Drive	.5, .7, 1, 1.5, 2, or 3
	Horsepower for Timing Belt Drive	.5, .7, 1, 1.5, 2, 3, 5, or 7.5
REDUCER/ MOTOR (Select 1 Only)	Grove/Baldor	GB
	Grove/Reliance	GR
	Dodge (TiGear)/Reliance	DR
	Dodge (TiGear)/Baldor	DB
VOLTAGE (Select 1 Only)	208-230/460 VAC, 3 PH, 60 HZ	V1
	575 VAC, 3 PH, 60 HZ	V2
	115 VAC, 1 PH, 60 HZ	V3

**Call-Up Option Fields** - Table J 8 lists the Option Fields in the order to be stated in the Call-Up.

Table J 8: Option Call-Up Fields

Option Description	Call-Up Entry
For Opposite Hand Unit	OPP
Brake Motor with Brake Coil Wired into Motor	B1
Brake Motor with 115 Volt Brake Coil Wired Separate from Motor (with “PE” option only)	B2
Timing Belt Drive	TB
Premium Efficient Motor	PE
Clutch - Brake (56 Double C-Face with 90 Volt Coil)	CB
Clutch - Brake Power Supply (Required on all standard orders with “CB” option)	PS

## Belt Conveyors - Slider Bed, Complete End Drive 400

### ITEM CLASS B 3 2 1

- |                                  |                                      |
|----------------------------------|--------------------------------------|
| (F1) BC END DRIVE UNIT           | (F6) POWER UNIT LH                   |
| (F2) BC IU CHAN RAIL SB and PANS | (F7) MOTOR                           |
| (F3) RETURN ROLLER               | (F8) BC EDRV CHAIN GUARD and SUPT    |
| (F4) SNUB ROLLERS                | (F9) BC 3.5", 6" or KNIFE EDGE IDLER |
| (F5) POWER UNIT RH               | (F10) BC EDU BELT and LACING         |

DESCRIPTION	Dwg. No.	16W	22W	28W	34W	40W
BC EDU SB 04 5-0/___ OALG	19072D	827051	827052	827053	827054	827055
BC EDU SB 04 6-0/___ OALG	19072D	827056	827057	827058	827059	827060
BC EDU SB 04 7-0/___ OALG	19072D	827061	827062	827063	827064	827065
BC EDU SB 04 8-0/___ OALG	19072D	827066	827067	827068	827069	827070
BC EDU SB 04 11-0/___ OALG	19072D	827071	827072	827073	827074	827075
BC EDU SB 04 12-0/___ OALG	19072D	827076	827077	827078	827079	827080
BC EDU SB 04 14-0/___ OALG	19072D	827081	827082	827083	827084	827085

BC = BELT CONVEYOR  
SB = SLIDER BED

EDU = END DRIVE UNIT - COMPLETE  
04 = 400 SERIES - 4-5/16" Dia. PULLEY

## Belt Conveyors - Slider Bed, Complete End Drive 600

### ITEM CLASS B 3 2 1

- |                                  |                                      |
|----------------------------------|--------------------------------------|
| (F1) BC END DRIVE UNIT           | (F6) POWER UNIT LH                   |
| (F2) BC IU CHAN RAIL SB and PANS | (F7) MOTOR                           |
| (F3) RETURN ROLLER               | (F8) BC EDRV CHAIN GUARD and SUPT    |
| (F4) SNUB ROLLERS                | (F9) BC 3.5", 6" or KNIFE EDGE IDLER |
| (F5) POWER UNIT RH               | (F10) BC EDU BELT and LACING         |

DESCRIPTION	Dwg. No.	16W	22W	28W	34W	40W
BC EDU SB 06 5-0/___ OALG	19073D	827086	827087	827088	827089	827090
BC EDU SB 06 6-0/___ OALG	19073D	827091	827092	827093	827094	827095
BC EDU SB 06 7-0/___ OALG	19073D	827096	827097	827098	827099	827100
BC EDU SB 06 8-0/___ OALG	19073D	827101	827102	827103	827104	827105
BC EDU SB 06 11-0/___ OALG	19073D	827106	827107	827108	827109	827110
BC EDU SB 06 12-0/___ OALG	19073D	827111	827112	827113	827114	827115
BC EDU SB 06 14-0/___ OALG	19073D	827116	827117	827118	827119	827120

BC = BELT CONVEYOR  
SB = SLIDER BED

EDU = END DRIVE UNIT - COMPLETE  
06 = 600 SERIES - 6-5/16" Dia. PULLEY

## Belt Conveyors - Slider Bed, Complete End Drive 800

### ITEM CLASS B 3 2 1

(F1) BC END DRIVE UNIT  
 (F2) BC IU CHAN RAIL SB and PANS  
 (F3) RETURN ROLLER  
 (F4) SNUB ROLLERS  
 (F5) POWER UNIT RH

(F6) POWER UNIT LH  
 (F7) MOTOR  
 (F8) BC EDRV CHAIN GUARD and SUPT  
 (F9) BC 3.5", 6" or KNIFE EDGE IDLER  
 (F10) BC EDU BELT and LACING

DESCRIPTION	Dwg. No.	16W	22W	28W	34W	40W
BC EDU SB 08 5-0/___ OALG	19073D	827121	827122	827123	827124	827125
BC EDU SB 08 6-0/___ OALG	19073D	827126	827127	827128	827129	827130
BC EDU SB 08 7-0/___ OALG	19073D	827131	827132	827133	827134	827135
BC EDU SB 08 8-0/___ OALG	19073D	827136	827137	827138	827139	827140
BC EDU SB 08 11-0/___ OALG	19073D	827141	827142	827143	827144	827145
BC EDU SB 08 12-0/___ OALG	19073D	827146	827147	827148	827149	827150
BC EDU SB 08 14-0/___ OALG	19073D	827151	827152	827153	827154	827155

BC = BELT CONVEYOR  
 SB = SLIDER BED

EDU = END DRIVE UNIT - COMPLETE  
 08 = 800 SERIES - 8-5/16" Dia. PULLEY



## Belt Conveyors - Slider Bed, Complete Center Drive 600, 800

### ITEM CLASS B 3 2 1

(F1) BC CENTER DRIVE UNIT  
 (F2) BC CDU-IDL SB RAILS and PANS  
 (F3) ROLLERS  
 (F4) SNUB ROLLERS  
 (F5) POWER UNIT RH

(F6) POWER UNIT LH  
 (F7) MOTOR  
 (F8) BC CD CHAIN GUARD and SUPT  
 (F9) BC 3.5", 6" or KNIFE EDGE IDLERS  
 (F10) BC CD BELT and LACING

DESCRIPTION	Dwg. No.	16W	22W	28W	34W	40W
BC CDU SB 06 DECL 9-0/_ OALG	19209D	827156	827157	827158	827159	827160
BC CDU SB 06 DECL 12-0/_ OALG	19209D	827161	827162	827163	827164	827165
BC CDU SB 06 INCL 9-0/_ OALG	19210D	827166	827167	827168	827169	827170
BC CDU SB 06 INCL 12-0/_ OALG	19210D	827171	827172	827173	827174	827175
BC CDU SB 08 DECL 9-0/_ OALG	19209D	827176	827177	827178	827179	827180
BC CDU SB 08 DECL 12-0/_ OALG	19209D	827181	827182	827183	827184	827185
BC CDU SB 08 INCL 9-0/_ OALG	19210D	827186	827187	827188	827189	827190
BC CDU SB 08 INCL 12-0/_ OALG	19210D	827191	827192	827193	827194	827195

DECL = USE ON DECLINE and HORIZONTAL SB = SLIDER BED  
 INCL = USE ON INCLINE CDU = CENTER DRIVE UNIT - COMPLETE  
 BC = BELT CONVEYOR  
 06 = 600 SERIES - 6-5/16" Dia. PULLEY w/3.5" Dia. TAKE-UP ROLLER  
 08 = 800 SERIES - 8-5/16" Dia. PULLEY w/3.5" Dia. TAKE-UP ROLLER

## Box Bed

### Belt Conveyors - Box Bed, Intermediate

**ITEM CLASS B 3 2 4**

(F1) RETURN ROLLERS

DESCRIPTION	Dwg. No.	16W	22W	28W	34W	40W
BC IS BB 6-0/___	19466D	822271	822272	822273	822274	822275
BC IS BB 12-0/___	19466D	822276	822277	822278	822279	822280

BC = BELT CONVEYOR  
BB = BOX BED

IS = INTERMEDIATE SECTION

### Belt Conveyors - Box Bed, Center Take-up Units

**ITEM CLASS B 3 2 3**

(F1) RETURN ROLLER

(F3) BC CENTER TAKE-UP UNIT

(F2) SNUB ROLLER

DESCRIPTION	Dwg. No.	16W	22W	28W	34W	40W
BC CT BB 3.5" SCREW-TU 12-0/___	194670	822281	822282	822283	822284	822285
BC CT BB 6" SCREW-TU 12-0/___	19468D	822286	822287	822288	822289	822290
BC CT BB 6" AIR-TU 12-0/___	19469D	822291	822292	822293	822294	822295

(F1) NON-REQUIRED

(F3) SPRING TAKE-UP

(F2) RETURN ROLLER

DESCRIPTION	Dwg. No.	16W	22W	28W	34W	40W
BC CT BB SPRING-TU 12-0/___	19500D	824095	824096	824097	824098	824099

BC = BELT CONVEYOR  
CT = CENTER TAKE-UP  
BB = BOX BED

3.5 = 3.5" Dia. SCREW TAKE-UP PULLEY  
6 = 6" Dia. SCREW TAKE-UP PULLEY  
AIR = 6" Dia. AIR TAKE-UP PULLEY

**Belt Conveyors - Box Bed, End Drive Units**

**ITEM CLASS B 3 2 1**

(F1) BC END DRIVE UNIT  
 (F2) RETURN ROLLER  
 (F3) SNUB ROLLER  
 (F4) POWER UNIT RH

(F5) POWER UNIT LH  
 (F6) MOTOR  
 (F7) BC EDRV CHAIN GUARD and SUPTN

DESCRIPTION	Dwg. No.	16W	22W	28W	34W	40W
BC ED BB 04 6-0/___	19470D	827196	827197	827198		
BC ED BB 06 6-0/___	19471D	827201	827202	827203	827204	827205
BC ED BB 08 6-0/___	19471D	827206	827207	827208	827209	827210

BC = BELT CONVEYOR  
 BB = BOX BED  
 ED = END DRIVE

04 = 400 SERIES - 4-5/16" Dia. PULLEY  
 06 = 600 SERIES - 6-5/16" Dia. PULLEY  
 08 = 800 SERIES - 8-5/16" Dia. PULLEY

## Belt Conveyors - Box Bed, SA2000 - Intermediate Drive

### ITEM CLASS B 3 2 1

#### How To Order

An SA2000 Intermediate Drive is ordered by entering a Call-Up line which includes the "Required Fields" to define the drive and "Options Fields" to define the options to be supplied.

**Call-Up Line Format** - State the Call-Up in the order shown below and in Table J 9 and Table J 10.

SA2000 - W - SPEED - HP - REDUCER/MOTOR - VOLTAGE - OPTIONS

#### Example - SA2000 Intermediate Drive Application

SA2000 Intermediate Drive - 22" "W" - Nominal Belt Speed of 60 fpm - 1 HP - Grove Reducer and Baldor Motor - 230-460VAC, 3 PH, 60HZ - Timing Belt Drive.

**Example Call-Up Line** - SA2000-22-60-1-GB-V1-TB

**Call-Up Required Fields** - Table J 9 lists the Required Fields in the order to be stated in the Call-Up.

Table J 9: Required Call-Up Fields

Field	Description	Call-Up Entry
"W" (Select 1 Only)	Between Frame	16, 22, 28, 34, or 40
SPEED (Select 1 Only)	Speed (fpm) for Chain Drive	30, 45, 60, 75, 90, 105, 120, 135, 150, 165, or 180
	Speed (fpm) for Timing Belt Drive	30, 45, 60, 75, 90, 105, 120, 135, 150, 165, 180, 200, 225, 250, 275, 300, 325, 350, 375, 400, 425, 450, 475, or 500
HP (Select 1 Only)	Horsepower for Chain Drive	.5, .7, 1, 1.5, 2, or 3
	Horsepower for Timing Belt Drive	.5, .7, 1, 1.5, 2, 3, 5, or 7.5
REDUCER/ MOTOR (Select 1 Only)	Grove/Baldor	GB
	Grove/Reliance	GR
	Dodge (TiGear)/Reliance	DR
	Dodge (TiGear)/Baldor	DB
VOLTAGE (Select 1 Only)	208-230/460 VAC, 3 PH, 60 HZ	V1
	575 VAC, 3 PH, 60 HZ	V2
	115 VAC, 1 PH, 60 HZ	V3

**Call-Up Option Fields** - Table J 10 lists the Option Fields in the order to be stated in the Call-Up.

Table J 10: Option Call-Up Fields

Option Description	Call-Up Entry
For Opposite Hand Unit	OPP
Brake Motor with Brake Coil Wired into Motor	B1
Brake Motor with 115 Volt Brake Coil Wired Seperate from Motor (with "PE" option only)	B2
Timing Belt Drive	TB
Premium Efficient Motor	PE
Clutch - Brake (56 Double C-Face with 90 Volt Coil)	CB
Clutch - Brake Power Supply (Required on all standard orders with "CB" option)	PS

**Belt Conveyors - Box Bed, SA2001 - Intermediate Drive - Low Profile**

**ITEM CLASS B 3 2 1**

**How To Order**

An SA2001 Intermediate Drive is ordered by entering a Call-Up line which includes the “Required Fields” to define the drive and “Options Fields” to define the options to be supplied.

**Call-Up Line Format** - State the Call-Up in the order shown below and in Table J 11 and Table J 12.

SA2001 - W - SPEED - HP - REDUCER/MOTOR - VOLTAGE - OPTIONS

**Example - SA2001 Intermediate Drive Application**

SA2001 Intermediate Drive - Low Profile - 22” “W” - Nominal Belt Speed of 60 fpm - 1 HP - Grove Reducer and Baldor Motor - 230-460VAC, 3 PH, 60HZ - Timing Belt Drive.

**Example Call-Up Line** - SA2001-22-60-1-GB-V1-TB

**Call-Up Required Fields** - Table J 11 lists the Required Fields in the order to be stated in the Call-Up.

Table J 11: Required Call-Up Fields

Field	Description	Call-Up Entry
“W” (Select 1 Only)	Between Frame	16, 22, 28, 34, or 40
SPEED (Select 1 Only)	Speed (fpm) for Chain Drive	30, 45, 60, 75, 90, 105, 120, 135, 150, 165, or 180
	Speed (fpm) for Timing Belt Drive	30, 45, 60, 75, 90, 105, 120, 135, 150, 165, 180, 200, 225, 250, 275, 300, 325, 350, 375, 400, 425, 450, 475, or 500
HP (Select 1 Only)	Horsepower for Chain Drive	.5, .7, 1, 1.5, 2, or 3
	Horsepower for Timing Belt Drive	.5, .7, 1, 1.5, 2, 3, 5, or 7.5
REDUCER/ MOTOR (Select 1 Only)	Grove/Baldor	GB
	Grove/Reliance	GR
	Dodge (TiGear)/Reliance	DR
	Dodge (TiGear)/Baldor	DB
VOLTAGE (Select 1 Only)	208-230/460 VAC, 3 PH, 60 HZ	V1
	575 VAC, 3 PH, 60 HZ	V2
	115 VAC, 1 PH, 60 HZ	V3

**Call-Up Option Fields** - Table J 12 lists the Option Fields in the order to be stated in the Call-Up.

Table J 12: Option Call-Up Fields

Option Description	Call-Up Entry
For Opposite Hand Unit	OPP
Brake Motor with Brake Coil Wired into Motor	B1
Brake Motor with 115 Volt Brake Coil Wired Separate from Motor (with “PE” option only)	B2
Timing Belt Drive	TB
Premium Efficient Motor	PE
Clutch - Brake (56 Double C-Face with 90 Volt Coil)	CB
Clutch - Brake Power Supply (Required on all standard orders with “CB” option)	PS

## Belt Conveyors - Box Bed, Idler Units

### ITEM CLASS B 3 2 2

(F1) SNUB ROLLER

DESCRIPTION	Dwg. No.	16W	22W	28W	34W	40W
BC IU BB 6-0/___	19474D	822324	822325	822326	822327	822328

BC = BELT CONVEYOR  
BB = BOX BED

IU = IDLER UNIT

## Miscellaneous

### Belt Conveyors - Belting

#### ITEM CLASS B 3 9 1

DESCRIPTION	16" W 12" Belt	22" W 18" Belt	28" W 24" Belt	34" W 30" Belt	40" W 36" Belt
BELT ___" PVC100 BRUSHED X FS	190355	190491	190550	190582	190595
LACING CLIPPER 1A ___"	190712	190713	190714	190715	190716
LACING BELT ALLIG #7 ___"	190880	190892	190894	190896	190898
BELT ___" PVC 100 RT X FS STYLE D	190360	190492	190580	190583	190594
LACING CLIPPER 1 ___"	190723	190724	190725	190726	190727
LACING BELT ALLIG #15 ___"	190966	190968	190970	190980	190990
BELT PVK-90 BRUSHED X FS ___" WIDE	190361	190362	190363	190364	190365
BELT PVK-90 RT X FS ___" WIDE	190368	190369	190370	190371	190372

## Belt Conveyors - Belting

Table J 13: Calculation of Belt Length

Belt Brushed x FS								
Style	400		600		800		1000	
01_	4'		5'		6'		----	
02_	---		6'		7'		8'	
Belt RT x FS								
03_	13'		14'		15'		---	
3A_	9'		10'		11'		---	
3B_	8'		9'		10'		---	
3C_	4'		5'		6'		---	
04_	---		15'		16'		17'	
4A_	---		11'		12'		13'	
4B_	---		10'		11'		12'	
4C_	---		6'		7'		8'	
Belt Brushed x FS and RT x FS								
Style	FS	RT	FS	RT	FS	RT	FS	RT
1J_	---		5'	9'	---		---	
1JA	---		5'	5'	---		---	
2J_	---		10'	9'	11'	9'	12'	9'
2JA	---		10'	5'	11'	5'	12'	5'
3J_	7'	13'	7'	14'	7'	15'	---	
3JA	7'	9'	7'	10'	7'	11'	---	
4J_	---		7'	15'	7'	16'	7'	17'
4JA	---		7'	11'	7'	12'	7'	13'
CSPS Accessories								
Acc. Code	Length							
AT3	3'							
AT6	5'							
AAT	5'							
KN1	1'							
KN2	2'							

### Belt Length Calculation

Belt Length FS = (Bed Length Field (8) or Extension Field (19)) × 2 + Table J 13.

Belt Length RT = (Bed Length (8) or Extensions Field (19)) × 2 + Table J 13.

## Belt Conveyors - Belt Personnel Guards

### ITEM CLASS B 3 9 2

DESCRIPTION	Dwg. No.	16" W	22" W	28" W	34" W	40" W
BC BPG INTER SECTION 12-0 W__	No Dwg.	823946	823947	823948	823949	823950
BC BPG INTER SECTION 9-0 W__	No Dwg.	823951	823952	823953	823954	823955
BC BPG INTER SECTION 6-0 W__	No Dwg.	823956	823957	823958	823959	823960
BC BPG INTER SECTION 3-0 W__	No Dwg.	823961	823962	823963	823964	823965

### GUARD FOR IDLER TERMINAL ENDS

BC BPG IU 3.5" & KE BOTTOM W__	22611 B	001251	001252	001253	001254	001255
BC BPG IU-6" BOTTOM W__	22612 B	001256	001257	001258	001259	001260

### GUARD FOR END DRIVE TERMINAL ENDS

BC BPG END DR 04 BOTTOM W__	22613 B	001261	001262	001263	001264	001265
BC BPG END DR 06 & 08 BOTTOM W__	22614 B	001266	001267	001268	001269	001270

BC = BELT CONVEYOR

BPG = BELT PERSONNEL GUARD

IU = IDLER UNIT

KE = KNIFE EDGE

DR = DRIVE

04 = 400 SERIES

06 = 600 SERIES

08 = 800 SERIES