

Field Manual
Powered Belt Conveyor

Installation Procedures, Maintenance, and
Parts Identification



To contact Intelligrated:
For service: Customer Service and Support (CSS)
Hotline 1-877-315-3400
On the World Wide Web: www.intelligrated.com

By mail:

Intelligrated
7901 Innovation Way
Mason, OH 45040

(513) 701-7300

Read these documents thoroughly before attempting to perform maintenance or repairs to the applicable Intelligrated conveyor system components or devices. Exercise extreme caution when working around moving and rotating conveyor equipment. Wear the proper clothing and safety equipment. DO NOT attempt to perform any maintenance until the equipment is de-energized, locked out and tagged out in accordance with established company procedures.

The information presented in these documents are correct at the time of publication. Intelligrated has made every effort to ensure that the information presented is correct and free from error. However, some errors or misprints may occur. Please contact Intelligrated with any corrections.

This document is copyrighted © 2010 by Intelligrated, all rights reserved. No Part of this manual may be reproduced and/or distributed to parties other than the customer and the customer's employees for whom it was originally produced.

The following terms are trademarks™ of Intelligrated; Accuglide™, BOSS™ UniSort™, EZ-set™. The following terms are registered trademarks® of Intelligrated; Accuzone®, UniSort®, E-Z Set®. Intelligrated® is a registered trademark.

Direct questions and comments concerning the information contained in this manual to:

Documentation Department
Intelligrated
7901 Innovation Way
Mason, OH 45040

Ph (513) 701-7300
Fax (513)701-7349

customerservice@intelligrated.com



Package Conveyors



 <p>Do Not Climb, Sit, Stand, Walk, Ride, or Touch the Conveyor at Any Time</p>	 <p>Do Not Perform Maintenance on Conveyor Until Electrical, Air, Hydraulic and Gravity Energy Sources Have Been Locked Out or Blocked</p>	 <p>Operate Equipment Only With All Approved Covers and Guards in Place</p>
 <p>Do Not Load a Stopped Conveyor or Overload a Running Conveyor</p>	 <p>Ensure That All Personnel Are Clear of Equipment Before Starting</p>	 <p>Allow Only Authorized Personnel To Operate or Maintain Material Handling Equipment</p>
 <p>Do Not Modify or Misuse Conveyor Controls</p>	 <p>Keep Clothing, BodyParts, and Hair Away from Conveyors</p>	 <p>Remove Trash, Paperwork, and Other Debris Only When Power is Locked Out and Tagged Out</p>
 <p>Ensure That ALL Controls and Pull Cords are Visible and Accessible</p>	 <p>Know the Location and Function of All Stop and Start Controls</p>	 <p>Report All Unsafe Conditions Jams should be cleared ONLY BY Authorized, Trained, Personnel</p>

POST IN PROMINENT AREA

Field Manual Issue and Revision Date(s)

1st Issue	March 2006
1st Revision	December 2006

Field Manual Revision Summary

Revision Date	Manual Section(s)	Revision Summary
December 2006	Section I	Update Part Numbers

Section G Installation Procedures

Accepting Shipment	G - 1
Shortages or Errors	G - 1
Lost or Damaged Shipment	G - 1
Claims and Returns	G - 1
Codes and Standards	G - 1
Warning Signs	G - 2
Safety Precautions	G - 2
Parts Replacement	G - 2
Factory Assistance	G - 2
Pre-Installation Set-up	G - 2
Conveyor Components / Styles	G - 4
Conveyor Styles - Component Assembly	G - 5
Terminal-End Section Assembly	G - 11
Transition Components	G - 13
Intermediate Drive - Field Assembly	G - 17
Installing the Belt	G - 19
Cutting the Belt Ends	G - 20
Splicing the Belt	G - 20
Electrical Wiring	G - 20
Pre-Start-Up Preparation	G - 21
Pre-Operation Check List	G - 21
Belt Tracking	G - 22
Principles of Belt Tracking	G - 22
Belt Tracking Instructions	G - 22
Examples of Belt Tracking	G - 22
Belt Tracking Check List	G - 26
Adjusting Belt Tension	G - 27
Snub Roller Adjustment	G - 28

Section H Maintenance

General	H - 1
Maintenance Safety	H - 1
Safety Precautions	H - 1
New Installations	H - 2
Maintenance Logs	H - 2
Initial Start-up and Run-in Period	H - 2
Chain and Sprockets	H - 2
Power Unit Reducer	H - 2
Scheduled Inspections and Maintenance	H - 3
Daily Inspection	H - 4
General Operation	H - 4
Safety Guards / Devices	H - 4
Weekly Inspection	H - 4
Belting	H - 4
Belt Lacing	H - 4
Rollers - Carrier, Pressure and Belt Return	H - 4
Electrical Devices	H - 4
General Structure	H - 4
Power Unit Reducer	H - 4
Monthly Inspection	H - 5
External Bearings	H - 5
Internal Bearings	H - 5
Power Unit - Motor	H - 5
Power Unit - Reducer	H - 5
Timing Belt Sprockets	H - 5
Timing Belt	H - 5
Chain Sprockets	H - 6
Chain	H - 6
Drive Pulley and Lagging	H - 6
Troubleshooting	H - 7

Section I Parts Identification

General Information	I - 1
SA2000 - Intermediate Drive	I - 2
SA2001 - Low Profile Intermediate Drive	I - 2
SA2030 - End Drive (Channel Frame)	I - 3
SA2031 - End Drive (Pick Frame High)	I - 3
SA2032 - End Drive (Pick Frame Low)	I - 3
SA2033 - End Drive (Channel Frame)	I - 3
SA2034 - Infeed End Idler	I - 4
SA2035 - Discharge End Idler	I - 4
SA2036 - Infeed End Idler - KE	I - 4
SA2037 - Discharge End Idler - KE	I - 4
SA2200 - Spring Take-Up	I - 5

SA2220 - Air Take-Up	-----	- 5
SA2300 - Three-Pulley Hitch Transfer	-----	- 6
SA2301 - Auxiliary Take-Up	-----	- 6
SA2310 - PTO Assembly	-----	- 7
SA2500 - Intermediate Section (Channel Frame, Roller Bed)	-----	- 8
SA2503 - Intermediate Section (Channel Frame, Slider Bed)	-----	- 8
SA2519 - Upper Bend Assembly	-----	- 8

SECTION G: INSTALLATION PROCEDURES

Accepting Shipment

Immediately upon delivery, check that all equipment received agrees with the bill of lading or carrier's freight bill. Any shipping discrepancy or equipment damage should be clearly noted on the freight bill before signing.

Shortages or Errors

Report any shortages or errors to the Manufacturer's Customer Service in writing within ten days after receipt of shipment.

Lost or Damaged Shipment

Report lost shipments to the Manufacturer's Shipping Department.

If shipping damage is evident upon receipt of the conveyor equipment, note the extent of the damage on the freight bill and immediately contact the transportation carrier to request an inspection. Do not destroy the equipment crating and packing materials until the carrier's agent has examined them. Unless otherwise agreed by the manufacturer, the Purchaser (User) shall be responsible for filing claims with the transportation carrier. A copy of the inspection report along with a copy of the freight bill should be sent to the Manufacturer's traffic department.

Claims and Returns

All equipment furnished in accordance with the Manufacturer's Agreement is not returnable for any reason except where authorized in writing by the Manufacturer. Notification of return must be made to the Manufacturer's Customer Service Department, and if approved, a "Return Authorization Tag" will be sent to the Purchaser (User). The return tag sealed in the "Return Authorization Envelope" should be securely affixed to the exterior surface on any side of the shipping carton (not top or bottom), or affixed to any smooth flat surface on the equipment, if not boxed.

Send authorized return shipment(s) transportation charges prepaid to the address indicated on the Return Authorization Tag. If initial shipment is refused, the Purchaser (User) shall be liable for all freight charges, extra cost of handling, and other incidental expenses.

Codes and Standards

The conveyor equipment is designed and manufactured to comply with the American National Standard Institute's "Safety Standards for Conveyors and Related Equipment" (ANSI B20.1) and with the National Electrical Code (ANSI/NFPA70).

The Purchaser/Operator shall be familiar with, and responsible for, compliance with all codes and regulations having jurisdiction regarding the installation, use, and maintenance of this equipment. Appropriate lockout/tagout policy and procedures shall comply with the minimum safety requirements outlined in the American National Standard Institute's current publication (ANSI Z244.1).

Warning Signs

Warning signs and labels posted on or near the conveyor equipment shall not be removed, painted over, or altered at any time. All safety devices, warning lights, and alarms associated with the conveyor system should be regularly tested for proper operation and serviced as needed. If the original safety item(s) become defective or damaged, refer to the conveyor parts list(s) of the bill(s)-of-materials for replacement part numbers.

Safety Precautions

- DO turn off conveyor power source(s) and affix appropriate lockout/tagout device(s) to operating controls before servicing the equipment. ONLY trained and qualified personnel who are aware of the safety hazards should perform equipment adjustments or required maintenance while the conveyor is in operation.
- DO observe all warning signs, lights, and alarms associated with the conveyor operation and maintenance, and be alert at all times to automatic operation(s) of adjacent equipment.
- DO use extreme caution near moving conveyor parts to avoid the hazard of hands, hair, and clothing being caught.
- DO NOT sit on, stand on, walk, ride, or cross (over or under) the conveyor at any time except where suitable catwalks, gates, or bridges are provided for personnel travel.
- DO NOT attempt to repair any equipment while the conveyor is running, replace any conveyor component without appropriate replacement parts, or modify the conveyor system without prior approval by the manufacturer.
- DO NOT operate the conveyor until all safety guards are securely in place, all tools and non-product materials are removed from or near the conveying surfaces, and all personnel are in safe positions.
- DO NOT remove or modify any safety devices provided on or with the conveyor.
- DO NOT clear jams or reach into any unit before first turning off the equipment power source(s) and affixing appropriate lockout/tagout device(s).

Parts Replacement

To minimize production downtime, selected conveyor spare parts should be stocked for replacement of defective components when required. Refer to the equipment bill(s)-of-materials where quantity requirements or code numbers are not indicated on the conveyor parts list. For added convenience, a list of selected spare parts for standard products is included in this manual (see Section I).

Factory Assistance

Contact Field Service for installation, operation, or maintenance assistance, or Customer One Protection (COP) for replacement parts.

Pre-Installation Set-up

Prior to installation, review the layout drawings to determine the proper location, orientation, and elevation of the conveyor sections. Read all instructions provided in this manual.

Review the plan drawings to identify the individual components that make up the conveyor unit and note the orientation, right-hand or left-hand, of the appropriate components and drives. Motor driven components have their orientation shown on the plan of the conveyor by a box depicting a chain guard on one side of the conveyor.

Snap a chalk line on the floor or other support base to establish the centerline of the conveyor. Arrange the conveyor items and mounting supports along this base line according to the layout drawing to ensure that all components are present and are compatible for proper assembly. Leave field-installed rollers, photoelectric controls, and other accessory items in the shipping containers until all conveyor items are completely assembled, mounted on supports, and adjusted for proper elevation.

End drives are for one-way travel and must be assembled at the discharge end of the conveyor. One-way Intermediate Drives should be assembled as close as possible to the discharge end of the conveyor. Intermediate Drives for reversing operation should be located near the middle of the conveyor.

Conveyor Components / Styles

The Powered Belt Conveyor product line consists of basic functional components that includes:

- Drives (with Power Unit) - End or Intermediate (Center) Type
- Intermediate Sections
- Idlers - Discharge and/or Infeed Type(s)
- Upper Bend
- PTO Connection / Three Pulley Device
- Belting - Friction-Surface or Traction-top

A Belt Conveyor's specific configuration (combination of the basic components) is identified and labeled as a "style".

Table G-1 Conveyor Style / Component Identification

Component	Style*					
	01					
Infeed End Idler	X					
Discharge End Drive	X					
Friction-Surface Belt	X					
	02	2J	2JA	2T	2TA	
Infeed End Idler	X	X	X	X	X	
Center Drive	X	X	X	X	X	
Discharge End Idler	X	X	X	X	X	
Upper Bend	--	X	--	X	--	
Power Feeder / PTO Connection	--	X	X	--	--	
Three Pulley Device	--	--	--	X	X	
Friction-Surface Belt	X	X	X	X	X	
	03	3A	3B	3C	3T	3TA
Infeed End Idler	X	X	X	X	X	X
Discharge End Drive	X	X	X	X	X	X
Upper Bend	X	--	X	--	X	--
Power Feeder / PTO Connection	X	X	--	--	--	--
Three Pulley Device	--	--	--	--	X	X
Friction-Surface Belt	X	X	X	--	--	--
Traction-Surface Belt	X	X	X	X	X	X
	04	4A	4B	4C	4T	4TA
Infeed End Idler	X	X	X	X	X	X
Center Drive	X	X	X	X	X	X
Discharge End Idler	X	X	X	X	X	X
Upper Bend	X	--	X	--	X	--
Power Feeder	X	X	--	--	--	--
Three Pulley Device	--	--	--	--	X	X
Friction-Surface Belt	X	X	X	--	--	--
Traction-Surface Belt	X	X	X	X	X	X

(*) All "styles" include Intermediate Sections to which their specific components are attached.

Conveyor Styles - Component Assembly

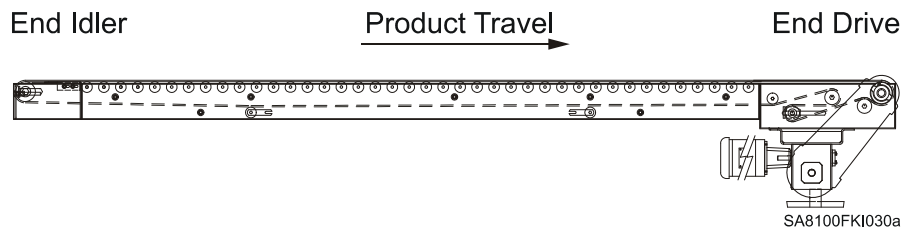

Figure G - 1 Style 1* Belt Conveyor

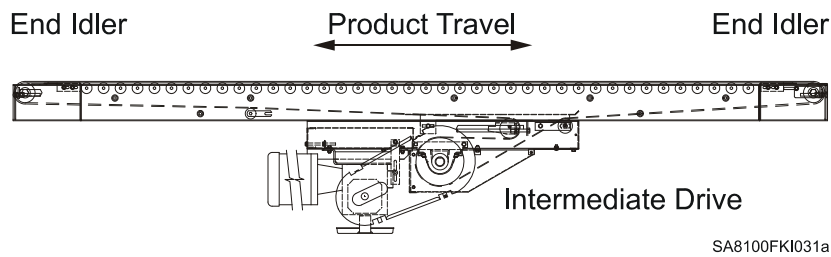

Figure G - 2 Style 2* Belt Conveyor

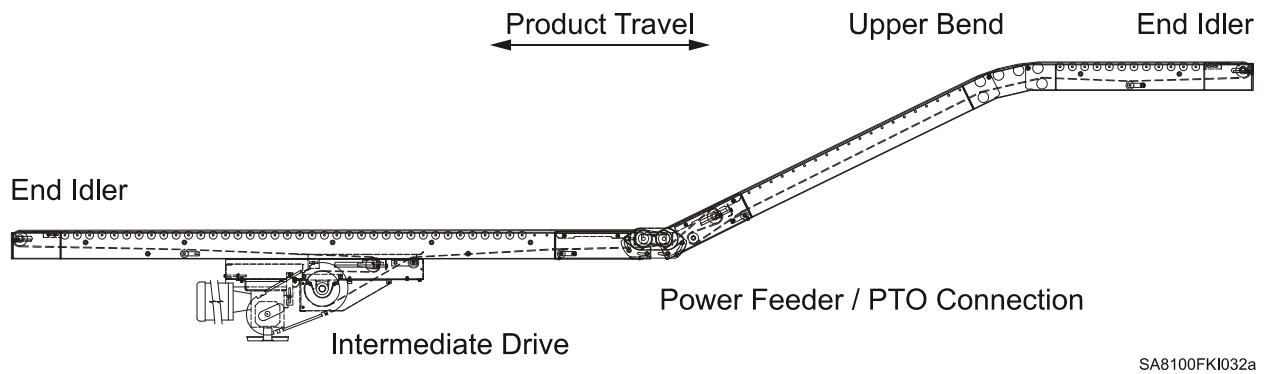
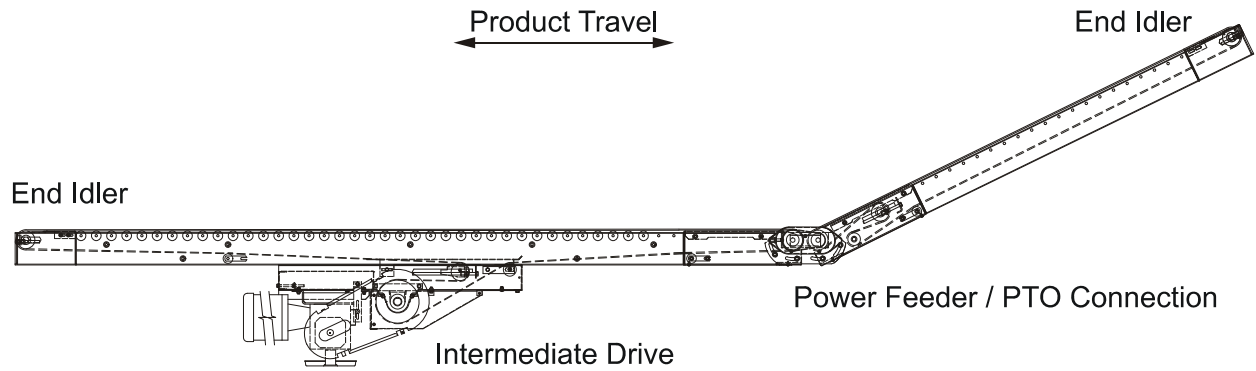

Figure G - 3 Style 2J* Belt Conveyor

(*) Friction Surface Belting provide (15^o max. Incline/Decline).



SA8100FKI033a

Figure G - 4 Style 2JA* Belt Conveyor

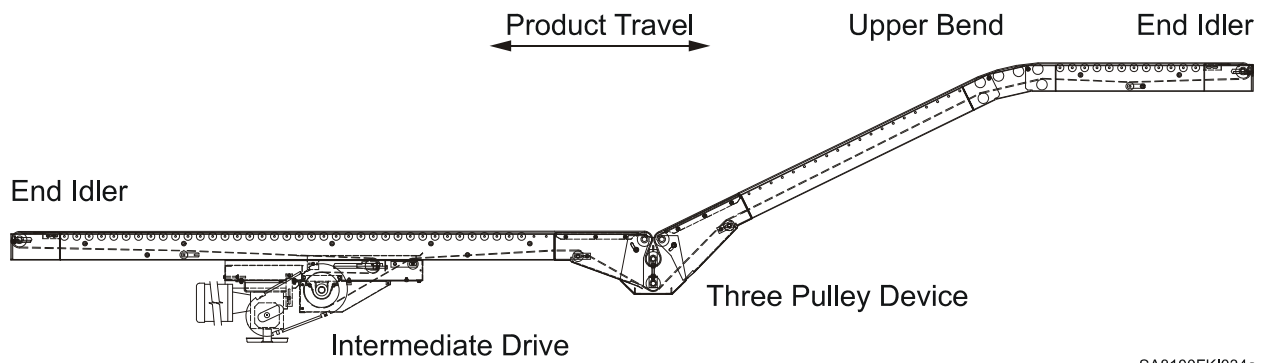

SA8100FKI034a

Figure G - 5 Style 2T* Belt Conveyor

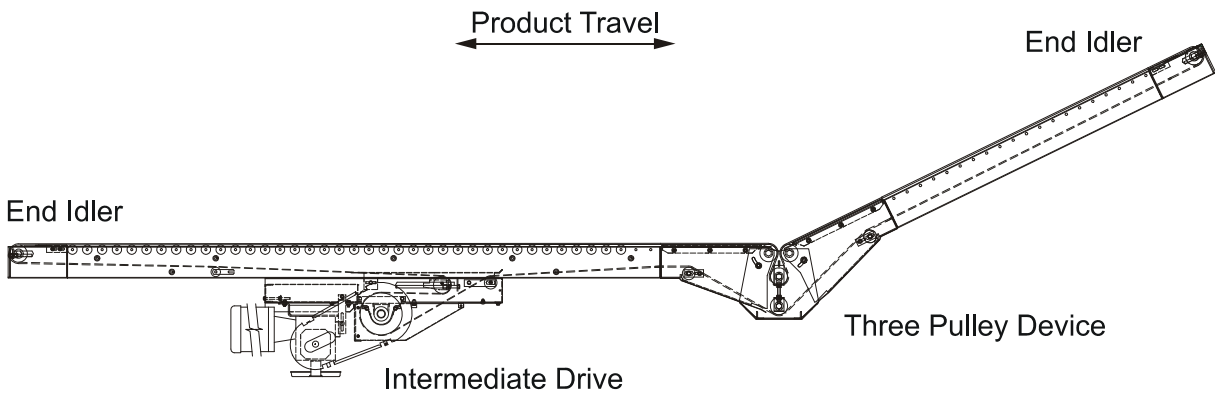

SA8100FKI035a

Figure G - 6 Style 2TA* Belt Conveyor

(*) Friction Surface Belt provided (15° max. Incline/Decline).

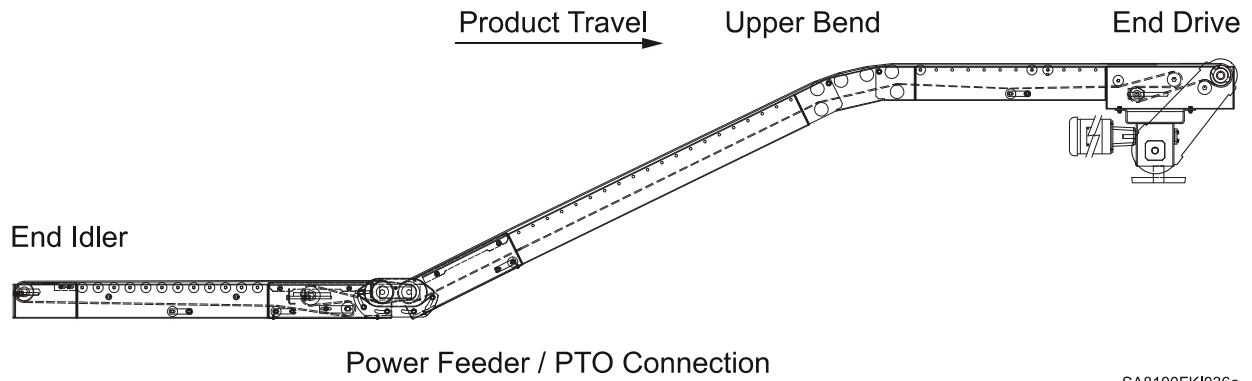

Figure G - 7 Style 3J** Belt Conveyor

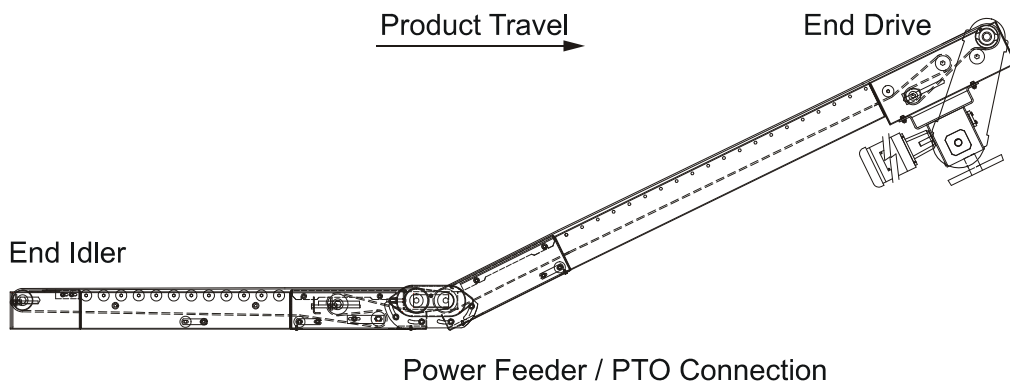

Figure G - 8 Style 3JA** Belt Conveyor

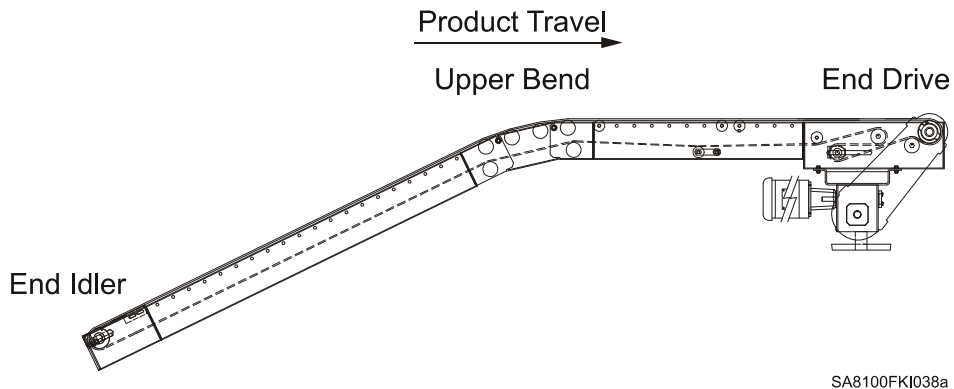
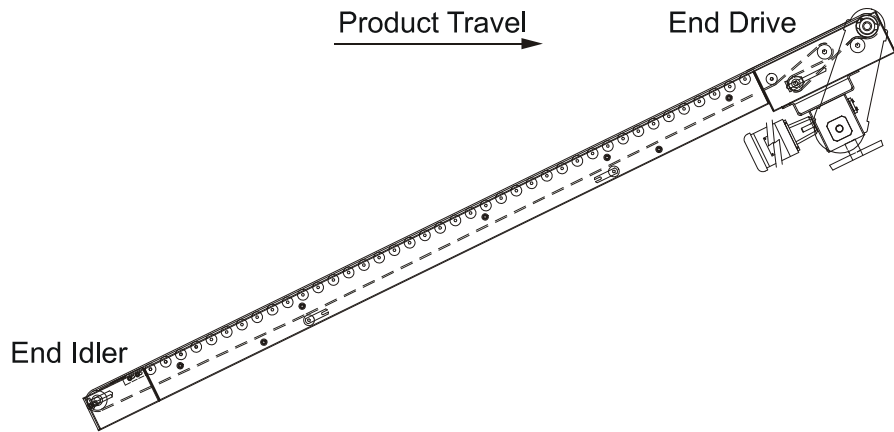

Figure G - 9 Style 3JB*** Belt Conveyor

(**) Friction Surface Belting for Horizontal and Traction Surface Belting for Incline/Decline.

(***) Traction-Surface Belting provided.



SA8100FKI039a

Figure G - 10 Style 3C*** Belt Conveyor

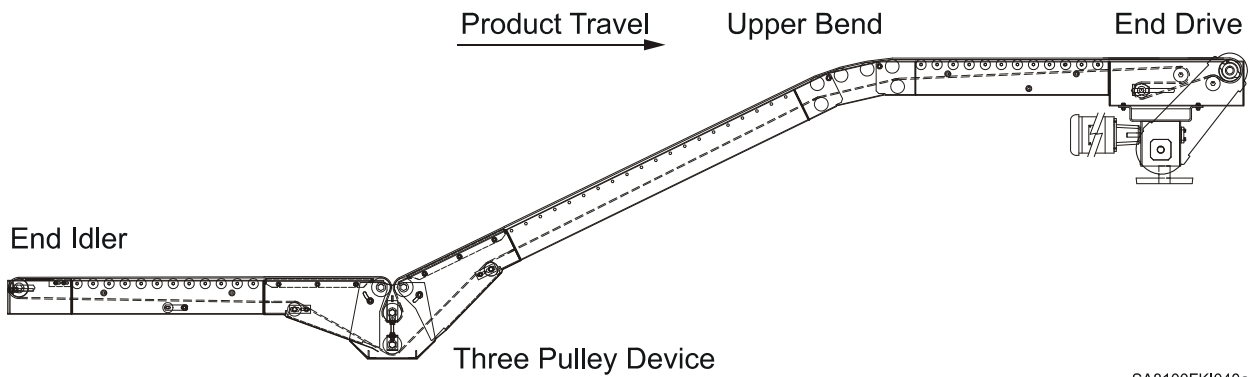

SA8100FKI040a

Figure G - 11 Style 3T*** Belt Conveyor

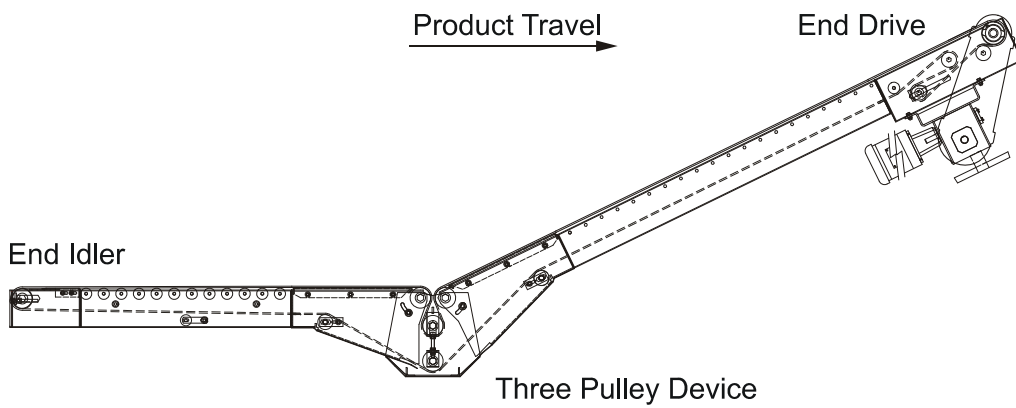

SA8100FKI041a

Figure G - 12 Style 3TA*** Belt Conveyor

(***) Traction-Surface Belting provided.

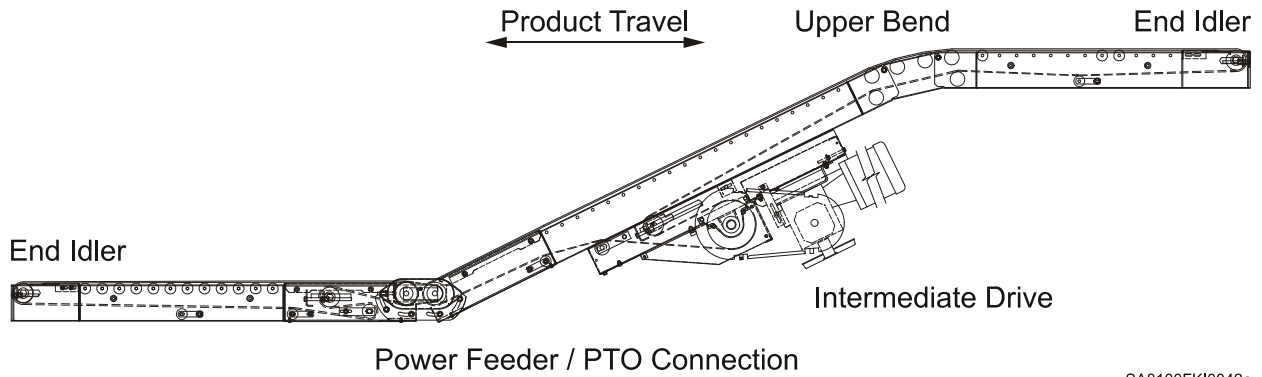

SA8100FKI0042a

Figure G - 13 Style 4J** Belt Conveyor

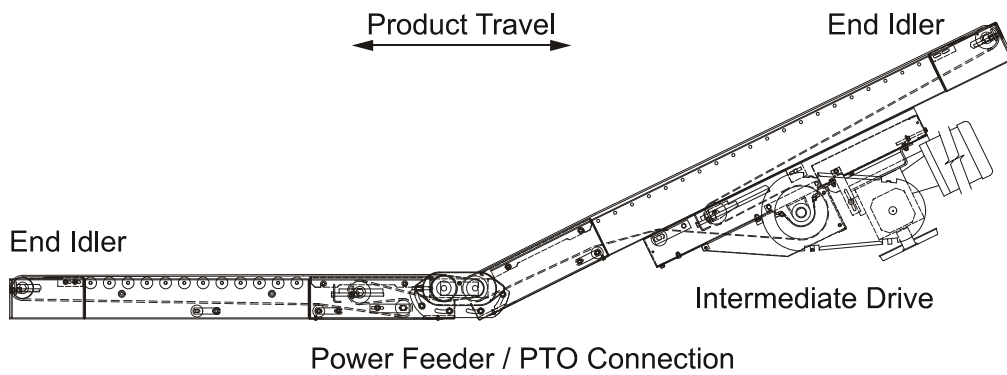

SA8100FKI0043a

Figure G - 14 Style 4A** Belt Conveyor

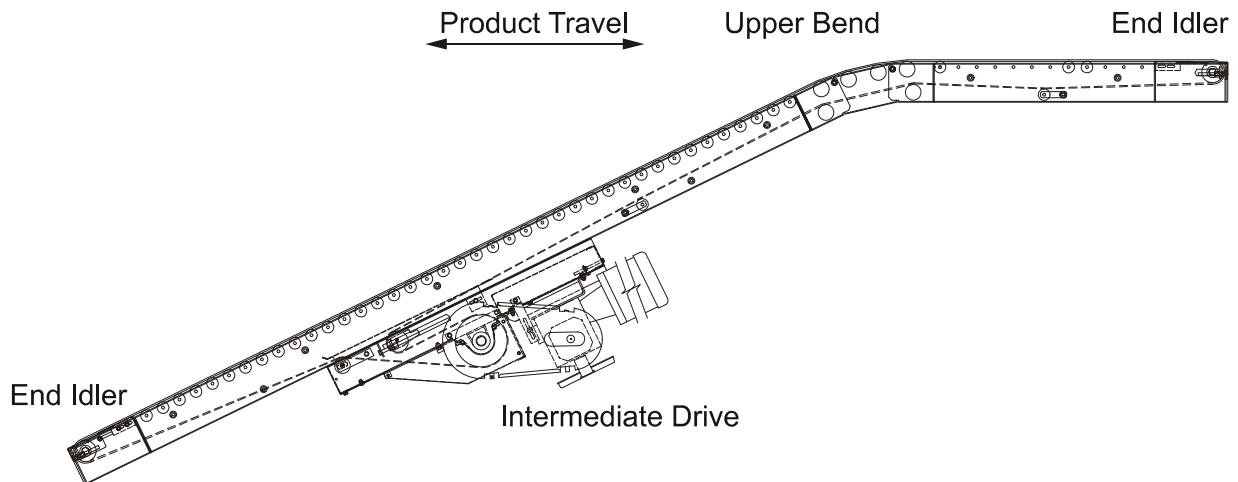

SA8100FKI044a

Figure G - 15 Style 4B*** Belt Conveyor

(**) Friction Surface Belting for Horizontal and Traction Surface Belting for Incline/Decline.

(***) Traction-Surface Belting provided.

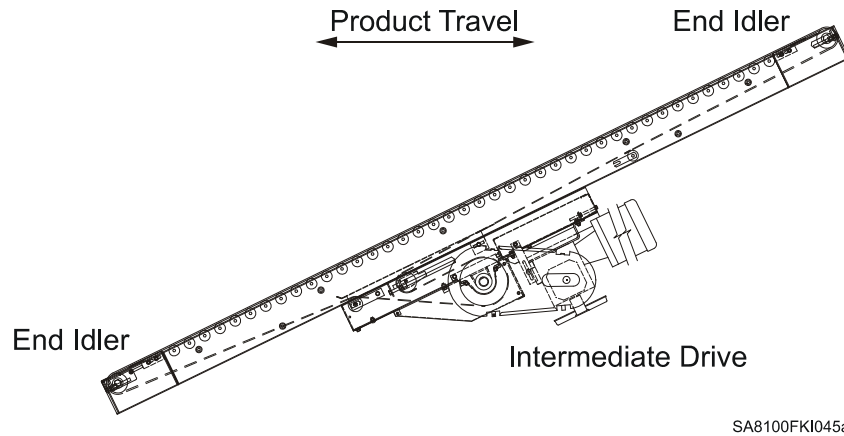

Figure G - 16 Style 4C*** Belt Conveyor

SA8100FKI045a

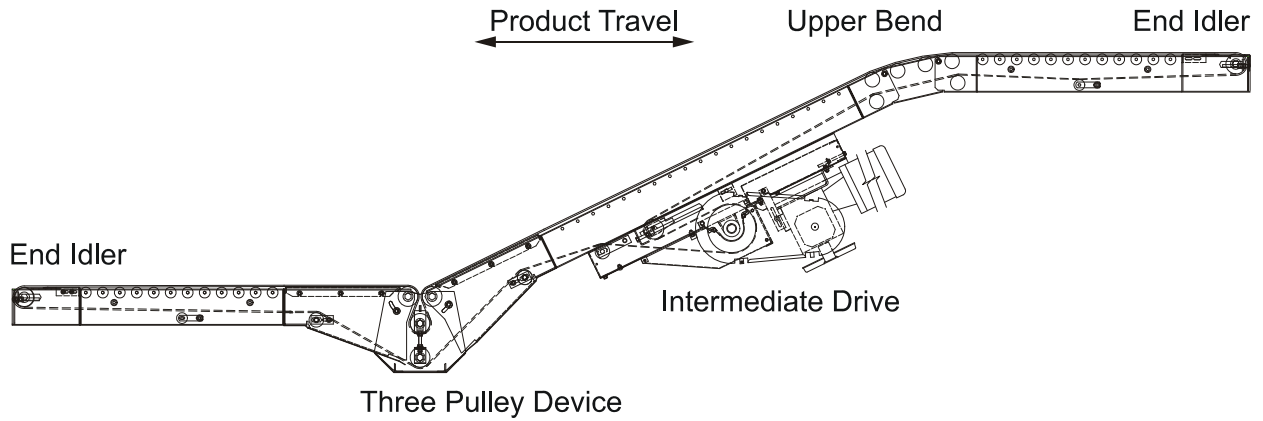

Figure G - 17 Style 4T*** Belt Conveyor

SA8100FKI0046a

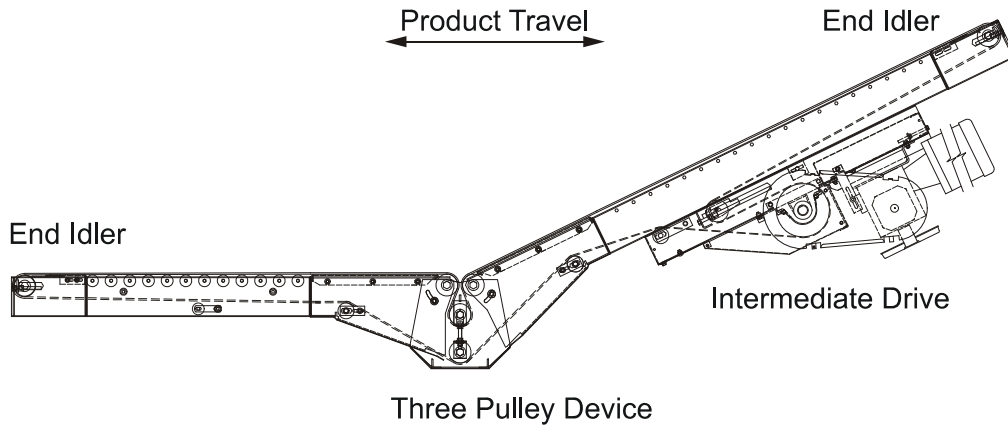

Figure G - 18 Style 4TA*** Belt Conveyor

(***) Traction-Surface Belting provided.

SA8100FKI0047a

Terminal-End Section Assembly

Step 1 - Field-assemble terminal-end (TE) components (Infeed Idler and Discharge Idler/ Drive) to their adjoining Intermediate Sections. Check system layout drawing for the required length of each Intermediate Section.

TE components have end-flanges that bolt directly to the Intermediate Sections with “welded” Butt Couplings, see Figure G - 19 left.

Intermediate Sections with the optional “bolted” Strap-Couplings require that a pair of “bolt-in” Butt Coupling Clips are bolted to the frame rails at one end. TE components bolt to the clips, see Figure G - 19 right.

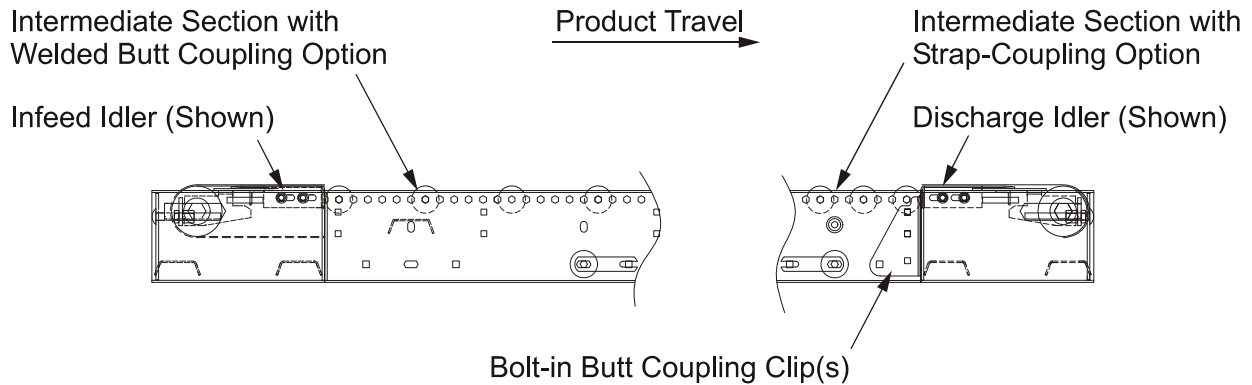

SA8100FKI048a

Figure G - 19 Attachment of TE Components to Intermediate Sections

Step 2 - Assemble the appropriate Floor/Ceiling Supports to the conveyor's TE Section(s). Check the conveyor's elevation requirements.

At the splice of Intermediate Sections, the support is located so that both sections are equally supported, see Figure G - 20 center.

When connecting a TE Section to an adjoining conveyor, two (2) supports are typically specified, see Figure G - 20 left.

A single support can be used to support two (2) adjoining conveyors. If the conveyors have different depth dimensions, a Connector Channel is used, see Figure G - 20 right.

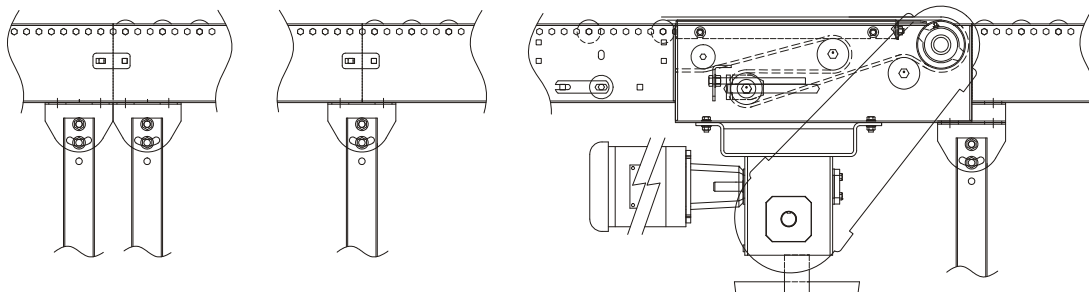

SA8100FKI049a

Figure G - 20 Mounting of Support (Floor-type shown)

Step 3 - Starting at either end of the conveyor, position the first TE Section in relation to the adjoining upstream/downstream conveyor or equipment.

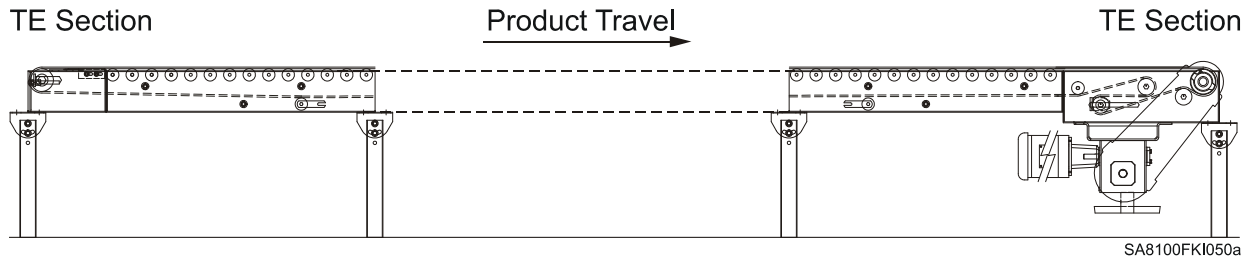

Figure G - 21 Install first TE Section at either end of Horizontal Conveyor

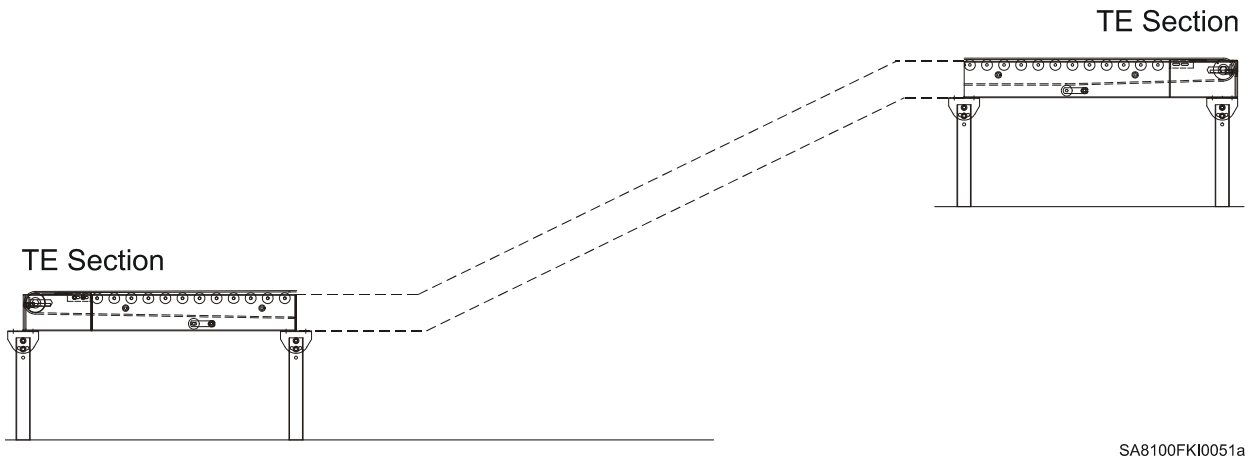
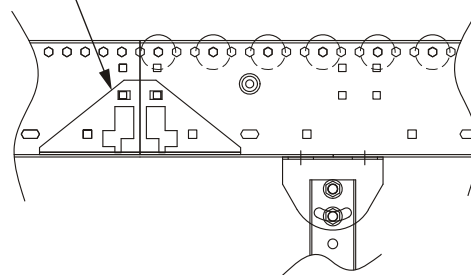
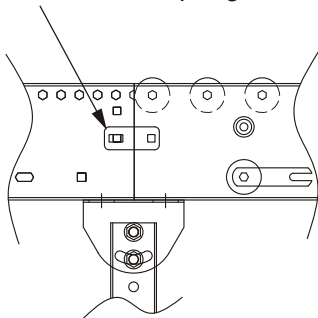

Figure G - 22 Install first TE Section at either end of Incline/Decline Conveyor

Step 4 - Working from the first-installed TE Section, position, splice and anchor the next Intermediate Section and/or other required components, see Figure G - 24, Figure G - 25 and Figure G - 26.

SD2900 bolted Strap-Connector (shown) or welded Butt-Coupling

Use SD2901 Bolted-Connector instead of SD2900 when support CANNOT be located at the splice.



SA8100FKI052a

Figure G - 23 Connecting/Supporting Adjoining Intermediate Sections

Transition Components

Many Style 3 and 4 conveyors include directional-transition components that provide a smooth change between the incline and horizontal planes of product travel. The installation of these components is covered in Steps 5-8.

Step 5 - To install an Upper Bend Unit:

1. Loosen the segment adjustment bolts.
2. Adjust the segments so that the horizontal/incline directional change is equally divided between the three (3) segments.
3. Retighten the adjustment bolts.
4. Mount a support to either the "center" segment (shown) or at one (or both) of the splice connections (check the system layout drawing for specific support mounting requirements).
5. Connect the unit to the adjoining TE Section and/or Intermediate Section(s).
6. Check alignment and tighten all hardware after unit is installed.

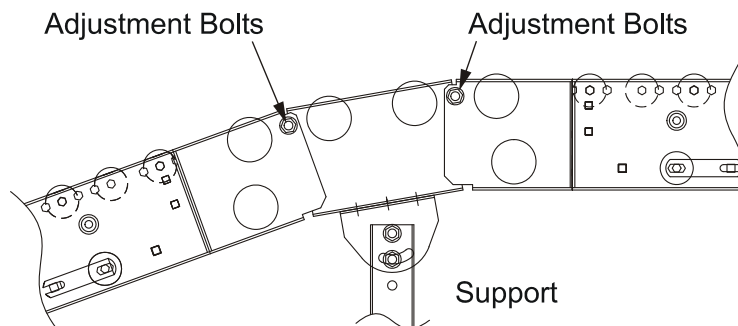

SA8100FKI053a

Figure G - 24 Installing Upper Bend Unit

Step 6 - To install a Two-Pulley PTO Unit:

1. Orient unit so that "take-up" segment is positioned to connect to the conveyor's adjoining "horizontal" Intermediate Section, see Figure G - 25.
2. Loosen the segment adjustment bolts.
3. Adjust the "middle" segment so that pulleys "Pa" and "Pb" are aligned with the carrying surface of the "feeding" (upstream) Intermediate Section.
4. Retighten bolts securing the two (2) segments.
5. Rotate the "downstream" segment around pulley "Pb" until its carrying surface is aligned with carrying surface of the downstream Intermediate Section.
6. Retighten bolts securing the middle and downstream segments.
7. Mount a support near the "center" of the assembly (shown) or at the splice connection(s) (check system layout drawing for specified support mounting requirements).
8. Connect the unit to the butt-couplings of the two (2) adjoining Intermediate Sections.
9. Check component alignment and retighten all hardware after unit is installed.

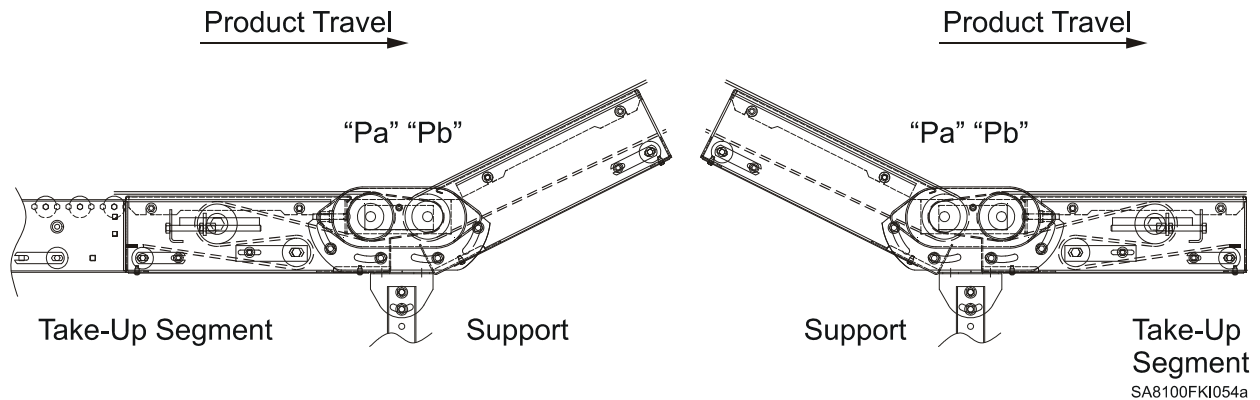
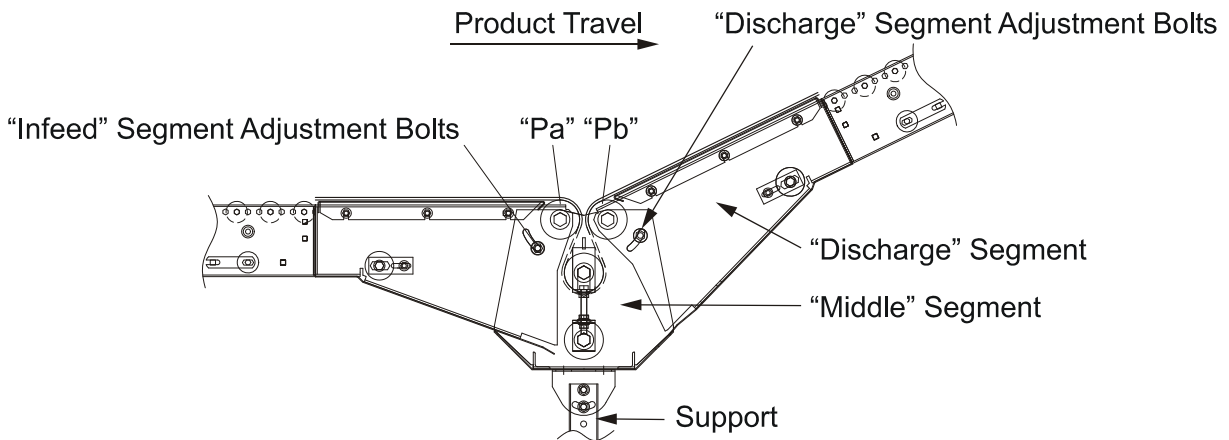

Figure G - 25 Installing Two-Pulley PTO Assemblies

Step 7 - To install a Three-Pulley Device:

1. Loosen the segment adjustment bolts.
2. Rotate the "middle" segment around pulley "Pa" until pulleys "Pa" and "Pb" are aligned carrying surface of the "infeed" segment.
3. Retighten adjustment bolts that secure "infeed" and "middle" segments.
4. Rotate the "discharge" segment around pulley "Pb" until it is aligned with the carrying surface of the "downstream" Intermediate Section.
5. Mount a support to the bottom flanges of the "middle" segment (shown) or at one (or both) ends of the unit. (Check system layout drawing for specified support mounting requirements.)
6. Connect the unit to the adjoining Intermediate Sections.
7. Check alignment of components and tighten all hardware after unit is installed.



SA8100FKI055a

Figure G - 26 Installing Three-Pulley Devices (Horizontal to Incline Assembly shown)

Step 8 - To install an Auxiliary Take-Up:

1. Orient unit so that the high-tension (T_1) side of the belt travels over the snub rollers before wrapping around the idler/take-up pulley(s), see Figure G - 27.
2. Check that the "planned" mounting position provides a 26" center-distance (minimum) between the Snub Roller and the "upstream*" Belt-Return Roller.
3. Assemble the unit to the Intermediate Section's bottom flanges.

(*) When looking at the Product / Belt's "downstream" direction of travel.

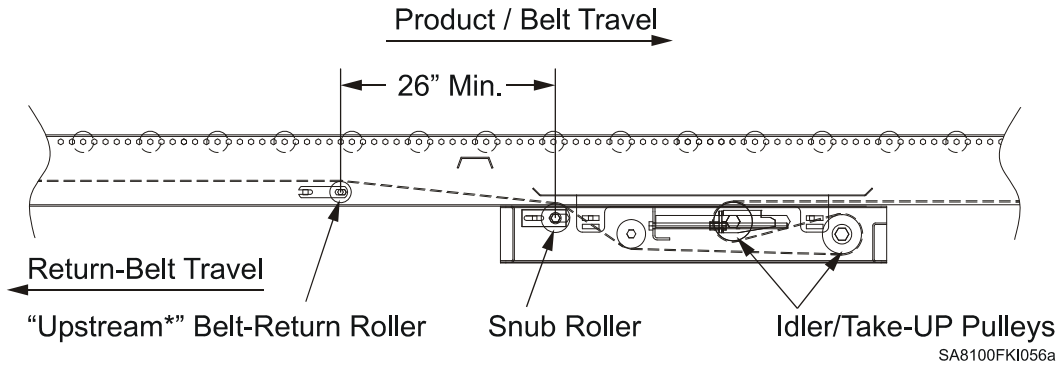

Figure G - 27 Installing Auxiliary Take-Up (Manual-type shown)

Intermediate Drive - Field Assembly

Style 2 and 4 Belt Conveyors feature an intermediate-type drive that must be field-assembled to an Intermediate Section when installing the conveyor. Refer to the system layout drawing to identify the drive's required location.

Step 9 (For Style 2 Horizontal Belt Conveyors):

1. Orient the Intermediate Drive so that the Drive Pulley "pulls" the belt (return run) over the unit's Snub Roller, see Figure G - 28.
2. Proceed to Step 11.

For reversible, two-way travel applications, orient the Intermediate Drive for the Product / Belt Travel direction that has the highest "effective belt pull" requirement.

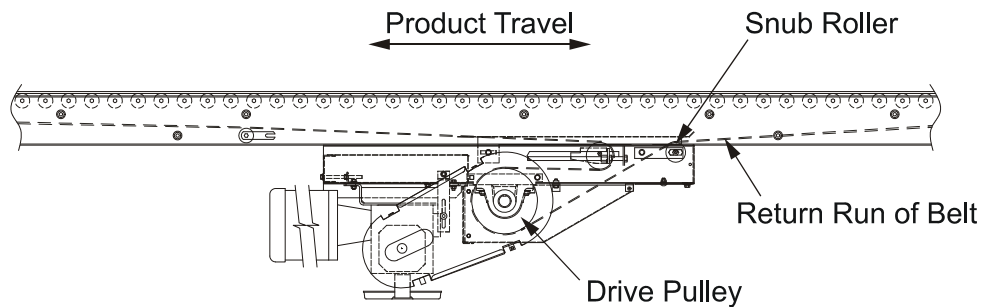

SA8100FKI057a

Figure G - 28 Style 2 - Intermediate Drive Orientation (Horizontal)

Step 10 (For Style 4 Incline/Decline Belt Conveyors):

1. Orient the Intermediate Drive so that the power unit's motor is located "above" the reducer, see Figure G - 29.
2. Proceed to Step 11.

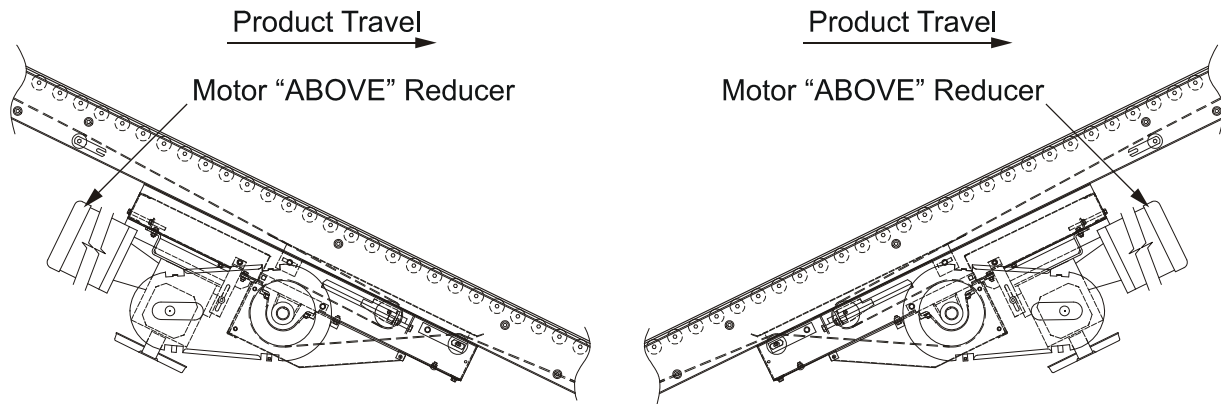

SA8100FKI058a

Figure G - 29 Style 4 - Intermediate Drive Orientation (Decline - left; Incline/Reversible - right)

Step 11 - Before attaching the "oriented" Intermediate Drive to the Intermediate Section, check that it's "planned" mounting location provides a "center-distance" of at least 26" between the Take-Up Pulley (fully-extended), Snub Roller, and Belt-Return Rollers, see Figure G - 30.

If either center-distance is less than 26", it will be necessary to do one of the following:

1. Change the Intermediate Drive's fore/aft position;
2. route the belt under one or both Belt Return Rollers; or
3. reposition one or both Belt-Return Roller(s).

Step 12 - Attach the drive to the bottom flanges of the selected Intermediate Section.

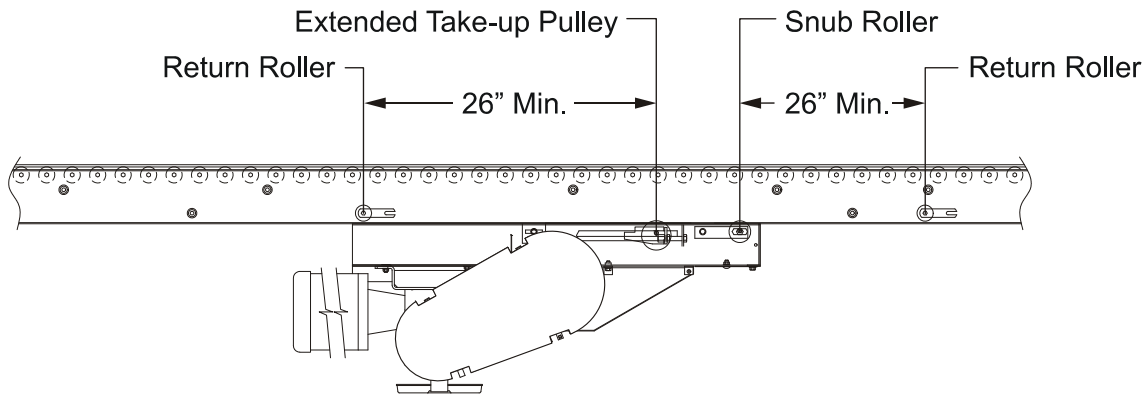

SA8100FKI059a

Figure G - 30 Center Intermediate Drive between Belt-Return Rollers

Installing the Belt

Use the following steps to install the belt.

1. Before starting the belt installation, make certain that:
 - all frame sections are level, properly aligned, and securely anchored,
 - all pulley and roller shafts are perpendicular to the conveyor frame,
 - all idler pulleys and rollers rotate freely,
 - no dips or humps exist along the conveyor bed surface, and
 - all sections are level.
2. Adjust all take-ups to their minimum take-up position.
3. Measure the required belt length.

For a short conveyor, thread a tape or rope through the conveyor following the path the belt will take and measure. Cut the belt to this length.

For longer units, the length of the conveyor can be doubled and 4'-0" added. This gives the approximate belt length required and cut to the approximate belt length.

4. Orient the belt properly on the unit.

For minimum friction (less belt drag), particularly on slider bed units, the brushed, non-glossy side of the belt must be face-down on the top side of the conveyor.

5. Thread the belt through the conveyor. Thread the belt through the bottom of the conveyor first. Position the belt near one end of the conveyor such that the brushed side of the belt is up and the first pulley to be encountered by the belt is the drive pulley. Large rolls of belting should be mounted on a shaft for ease of unrolling.

An alternative is to unroll the belt and lay it on the floor in large loops, taking care to avoid kinking the belt. The belt may then be pulled from the pile in the same manner it is pulled from a coil. Attach a suitable pulling clamp and cable to the lead end of the belt, see Figure G - 31. The clamp should distribute the pull evenly across the width of the belt. Then, with the assistance of a puller on the cable or rope, the lead end of the belt can be guided through the final path, around the drive and take-up pulleys, over return rollers, around end pulleys, and finally, up to the top of the conveyor where it can be joined with the other end.

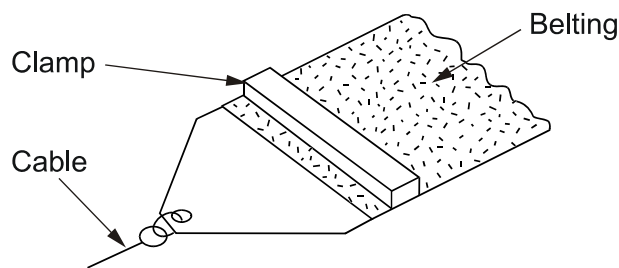

SA8100FKI060a

Figure G - 31 Belt Pulling Device

Cutting the Belt Ends

Use the following steps to cut the belt ends:

1. Pull the belt ends together and secure them to the bed with appropriate clamps, see Figure G - 32. If excess belt remains, overlap the belt ends and pull the belt until the belt sag between the return rollers is about 1" (with conveyor take-up at minimum take-up position); then mark the cut line with chalk or pencil.

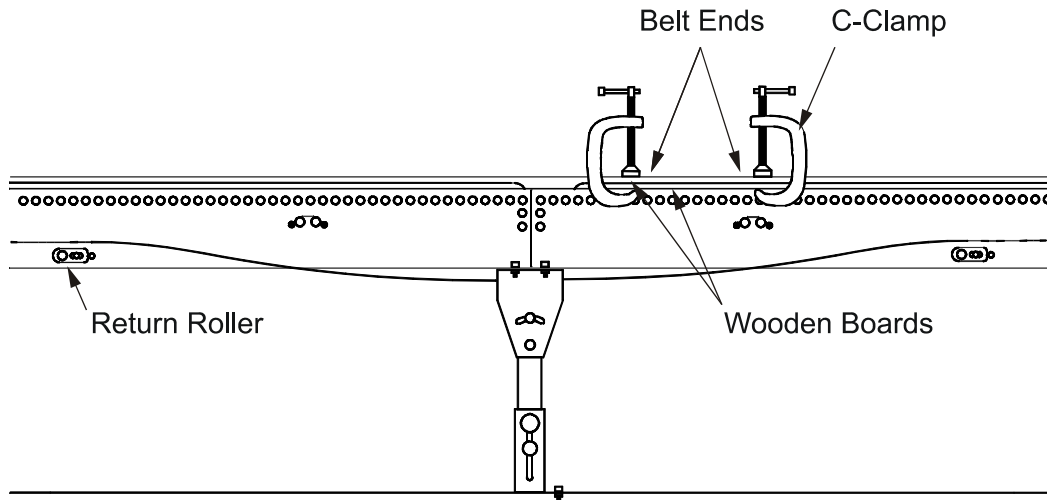

SA8100FKI061a

Figure G - 32 Clamping Belt Ends

2. Belt ends must be cut precisely square to ensure proper belt tracking and even distribution of the tension load through the belt splice.
 - Using chalk or pencil, mark the center of the belt at a number of points about 1 foot apart in the vicinity of the planned cut.
 - Using a straightedge, mark the centerline of the belt by passing the line through as many center marks as possible.
 - Using a steel square, mark the cut line perpendicular to the drawn centerline.
 - Carefully cut the belt with a sharp knife or belt cutting tool.
3. Recommended: Corners on squared cut ends of the belt should be chamfered by cutting off a triangle measuring 1/2" (along the belt width) by 1-1/2" (measured along the belt length).
4. Recommended: Rough tops, ribs, chevrons, etc. should be skived back about 1" from the belt ends before lacing.

Note: Skiving is assumed by belting and lacing manufacturers when sizing belt fasteners for these types of belts.

Splicing the Belt

Splice the belt with the supplied lacing. Follow the lacing manufacturer's instructions.

Electrical Wiring

Electrical wiring must be installed by a competent licensed electrician. The licensed electrician must be familiar with the operation and adjustment requirements of the conveyor so that the conduit and apparatus do not interfere with required access.

Pre-Start-Up Preparation

CAUTION: To prevent accidental start-up, make certain electrical power to the Power Unit is turned off and locked out.

Pre-Operation Check List

The following describes the check list prior to equipment start-up:

1. Check conveyor elevation and adjust supports as needed.
2. Check conveyor alignment (lengthwise and widthwise) with a spirit level. Adjust supports or add shims as needed and securely tighten all mounting bolts.
3. Check that all pulleys and rollers are mounted perpendicular (90°) to the direction of belt travel.
4. Check belt sag and adjust take-up pulley as needed. Do not over tension the belt.
5. Check driver/driven sprocket alignment with a straightedge. Securely tighten all sprocket fasteners.
6. Check drive chain tension and adjust as needed. Securely tighten all mounting bolts.
7. Check motor wiring connections.
8. Check other wiring connections and test all conveyor electrical controls for proper operation.
9. Check that all conveyor safety guards removed during the installation have been replaced.
10. Check that tools and all installation materials have been removed from the conveyor.
11. Check that the reducer lubricant is up to the oil level plug. If the reducer requires additional lubricant, refer to the manufacturer's tag attached to the reducer before adding.

Note: Before reinstalling the oil level and fill plugs, treat the plug threads to prevent oil leakage.

12. Review Safety Precautions listed in this Section. See "Safety Precautions" on page G - 2.

Belt Tracking

At this point, the conveyor is properly installed, all sections are aligned, and all carrier rollers are level and square with the frame. The belt is installed with all pulleys, snub, and return rollers at right angles to the conveyor frame, and all pre-start-up precautions observed. Now you are ready to track the belt.

WARNING: Belt tracking is performed while the conveyor is running and is dangerous. Only trained and qualified personnel must perform the belt tracking function. The personnel must be instructed to always be alert for any unsafe condition and to use extreme care when tracking the belt.

Principles of Belt Tracking

You must understand the principles of belt tracking in order to properly track the belt:

- **Crowned Pulleys** - Belts connecting parallel shafts tend to run toward that part of the pulley which is largest in diameter. Therefore, pulleys are crowned to keep the belt on center.
- **Taut Belt** - The belt must be sufficiently tensioned to not slip on the drive pulley. DO NOT overtighten.
- **Parallel Shafts** - If the pulley shafts are not parallel, the belt will creep toward the side where the shaft centers are closest. For pulley adjustment, see Figure G - 35 through Figure G - 40.

Belt Tracking Instructions

1. When first tracking the belt, station qualified personnel at each end of the conveyor to observe possible belt tracking problems.
2. It is seldom possible to make pulley shafts perfectly parallel. Corrective adjustments must be made with the snub rollers. See Figure G - 42 through Figure G - 45.
3. A common mistake is to adjust the end pulleys for any belt tracking problem. It is proper to adjust the end pulleys only for mis-tracking on the pulley at the discharge end of the conveyor, see Figure G - 35.
4. Note that the belt creeps toward the side of the pulley or snub roller that it touches first. Adjustments should be made accordingly, see Figure G - 34 through Figure G - 37.
5. All adjustments should be slight and you must allow sufficient time for the belt to react to the adjustment, (especially if the conveyor operates at slow speeds). Multiple revolutions of the belt are required for the belt to reach equilibrium.

Examples of Belt Tracking

As shown in Figure G - 35 through Figure G - 40, the belt always creeps to the right side of the conveyor. The right side of the conveyor is the side to your right when you are facing in the direction of forward travel of the product, see Figure G - 33. For reversible conveyors, forward travel is that direction of travel which is used to convey the largest amount of product.

The terminal ends are identified by their location in relation to the forward direction of product travel.

The conveyor's infeed end (forward travel) is referred to as the "tail" end, and the discharge end is the "head" end, see Figure G - 34.

On reversible units, the head and tail end designations will remain the same for both directions of travel once the forward direction is established.

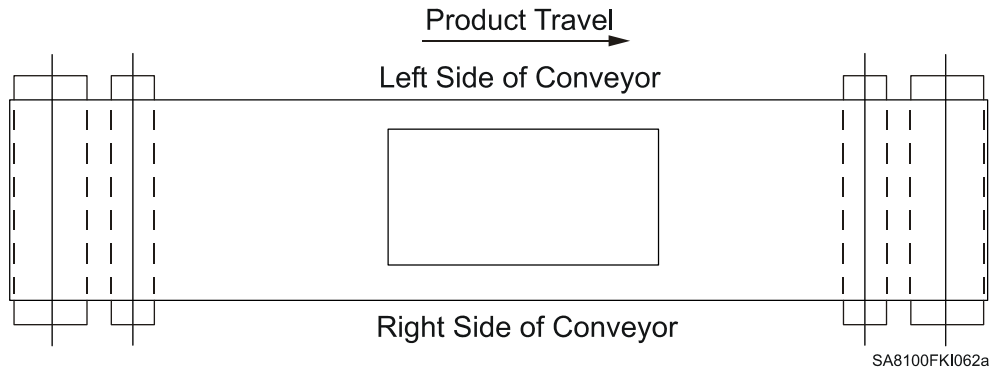

Figure G - 33 Conveyor "Side" Identification - When Looking in the Direction of Travel

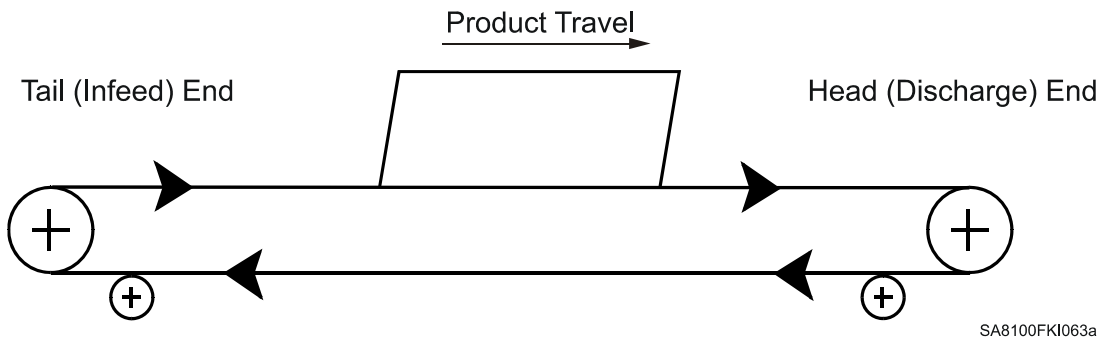

Figure G - 34 Product / Belt Travel From Tail End to Head End

If the belt traveling "Forward" mis-tracks toward the "right" side of the conveyor and Head Pulley:

1. Advance the right side of the Head Pulley forward (direction "F"); and or
2. Adjust the left side of the Head Pulley to the rear (direction "R").

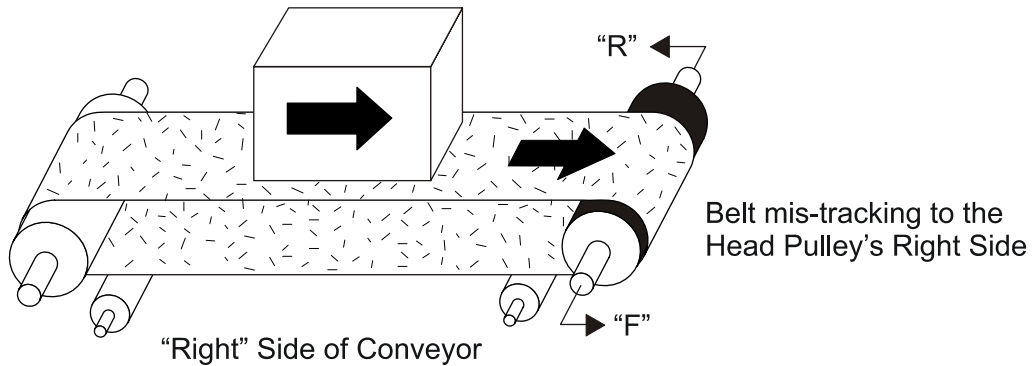
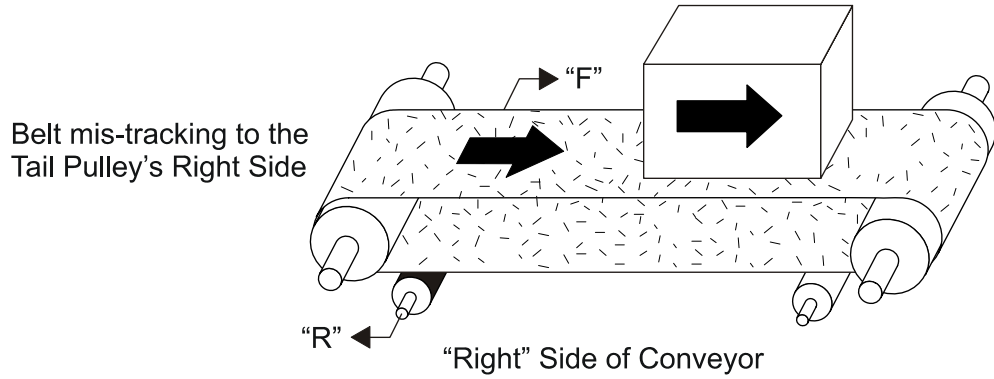

Figure G - 35 Head Pulley Adjustment(s) - Right Side Forward ("F"), Left Side Reward ("R")

If the belt (traveling “Forward”) mis-tracks toward the “right” side of the conveyor’s Tail Pulley:

1. Advance the right side of the tail-end Return Roller to the rear (direction “R”); and/or
2. Adjust the left side of the tail-end Return Roller forward (direction “F”).



SA8100FKI065a

Figure G - 36 Adjusting the Tail-End Return Roller

If the belt (traveling “Forward”) mis-tracks toward the “right” side of the conveyor’s Upper Bend:

1. Advance the right side of upper-bend Rollers “A” and “B” forward (direction “F”); and/or
2. Adjust the left side of rollers to the rear (direction “R”).

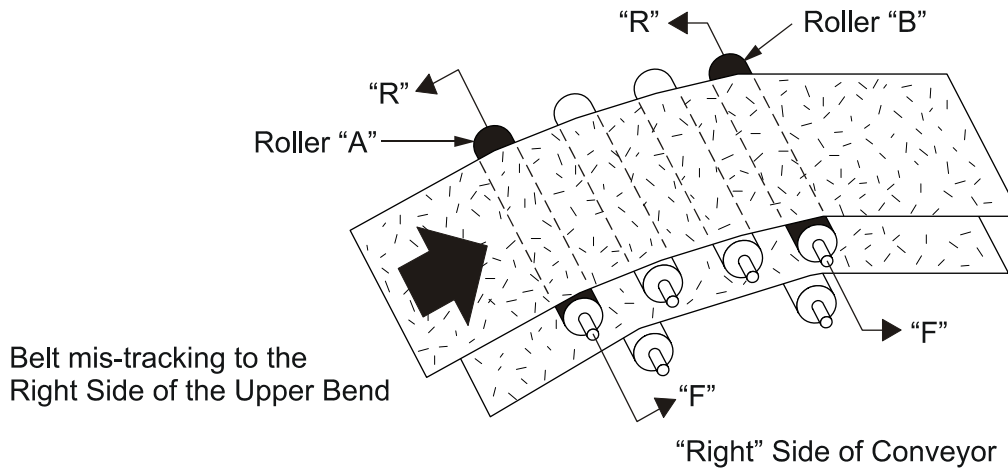

SA8100FKI066a

Figure G - 37 Adjusting the Upper Bend Rollers

If the belt (return run) mis-tracks toward the “right” side of the conveyor’s Upper Bend:

1. Advance the right side of Snub Rollers “A” and “B” to the rear (direction “R”); and/or
2. Adjust the left side of rollers forward (direction “F”).

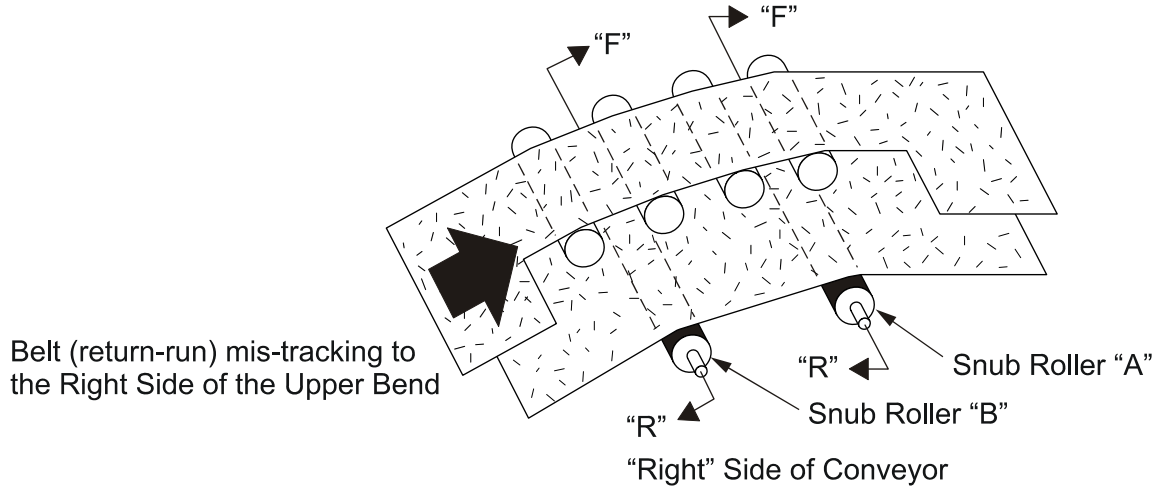

SA8100FKI067a

Figure G - 38 Adjusting the Upper Bend Snub Rollers for Tracking Belt (Return Run)

The following figures, Figure G - 39 and Figure G - 40, cover the “tracking” of the belt (return run) through an Intermediate Drive, Figure G - 39 - Style 2 Horizontal / Style 4 Decline Conveyor, Figure G - 40 - Style 4 Incline Conveyor.

If the belt (return-run) mis-tracks toward the “right” side of the Intermediate Drive:

1. Advance the right side of Snub Roller “A” to the rear (direction “R”); and/or
2. Adjust the left side of roller forward (direction “F”).

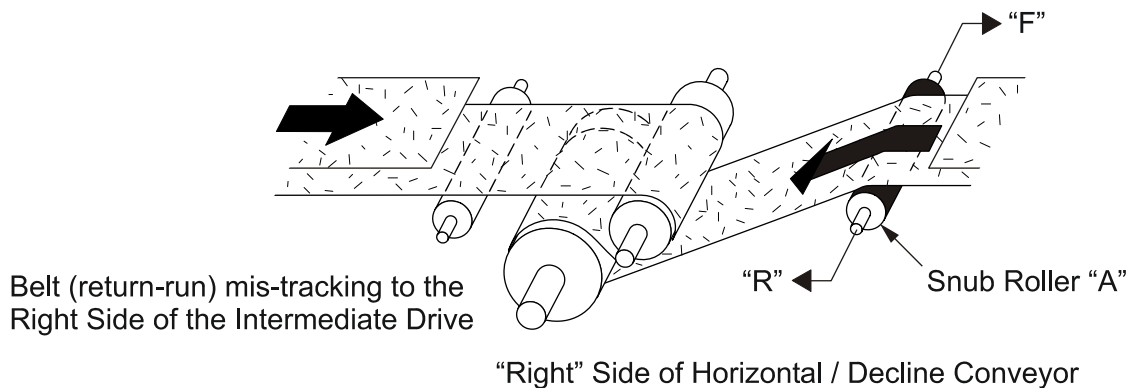

SA8100FKI068a

Figure G - 39 Adjusting Snub Roller ahead of Intermediate Drive

If the belt (return-run) mis-tracks toward the “right” side of the Intermediate Drive:

1. Advance the right side of Snub Roller “A” to the rear (direction “R”); and/or
2. Adjust the left side of roller forward (direction “F”).

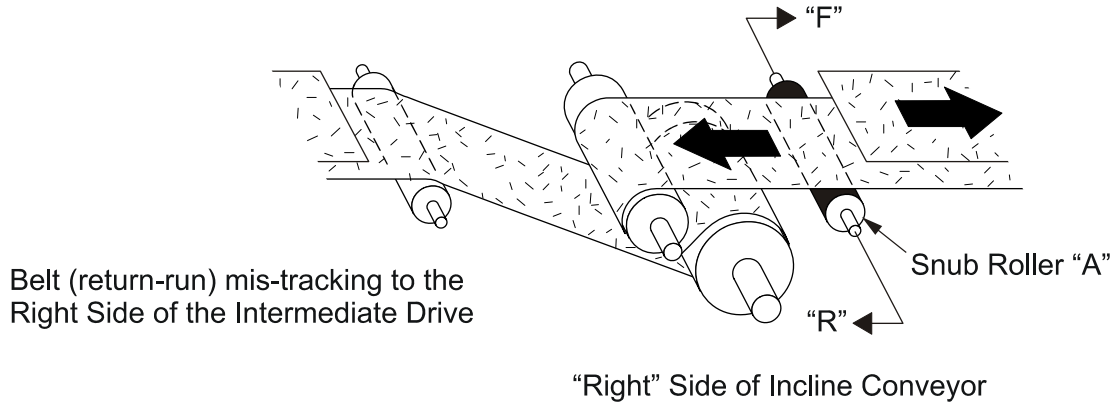

SA8100FKI069a

Figure G - 40 Adjusting Snub Roller ahead of Intermediate Drive

Belt Tracking Check List

1. Check the entire belt path for serious tracking problems that required immediate attention.
2. Watch the belt’s position at a given point for at least one complete rotation. If the belt does wander off center and then returns back to the center position, there is no need to make any adjustments. When the belt wanders off center, it is caused by camber in the belt length which will tend to straighten out in time.
3. (Roller Bed Only) If the upper run of the belt moves off center in a particular section, check that section to see if the rollers are square to the frame rails. If they are not at right angles with the frame, the section(s) must be straightened.
4. If the upper run of belt runs “off-center” the full length of the conveyor, first make adjustments of the Snub Roller as shown in Figure G - 36. Then, if necessary, adjust the End Pulley as shown in Figure G - 35.
5. Observe the belt’s return run and its position on each return roller. Adjust any roller that causes the belt to move off center.
6. If the belt mis-tracks at the Upper Bend Unit, adjust the Upper Bend and/or Snub Rollers as shown in Figure G - 37 and Figure G - 38.
7. If the belt mis-tracks at the Intermediate Drive, adjust the Snub Roller proceeding the drive as shown in Figure G - 39 and/or Figure G - 40.
8. On reversible unit, first track the belt in the forward direction of travel, then reverse the conveyor and repeat the tracking steps.

Adjusting Belt Tension

Adjust the Take-up Pulley until the belt's tension is sufficiently taut to prevent the belt from slipping on the drive pulley when the conveyor is turned-on. **DO NOT** over-tension. Excessive tension will reduce component life.

Adjust both sides equally
and in small increments

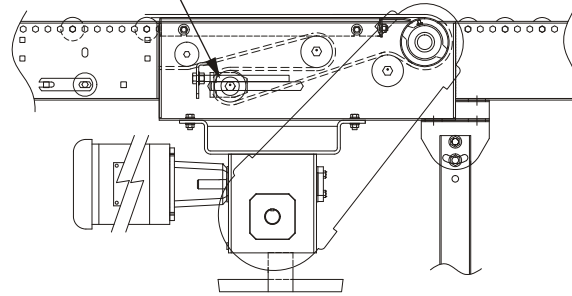

SA8100FKI070a

Figure G - 41 SA2030 End Drive - Take-Up Adjustment

Adjust both sides equally and in small increments

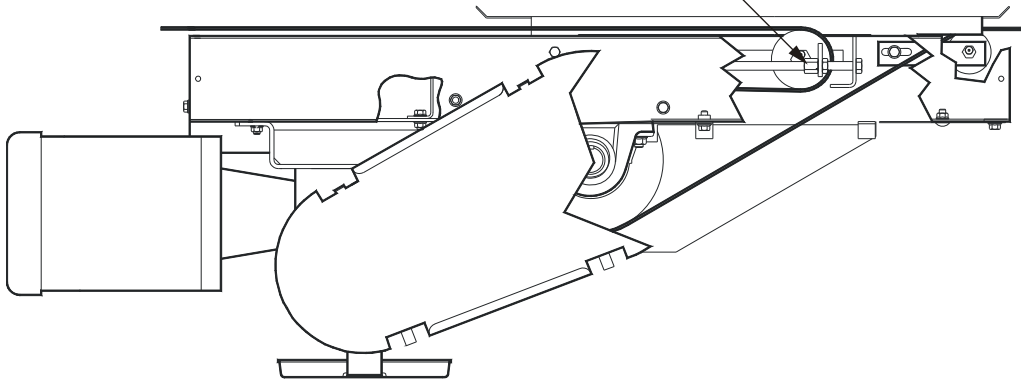

SA8100FKI071a

Figure G - 42 SA2000 Intermediate Drive - Take-Up Adjustment

Adjust both sides equally and in small increments

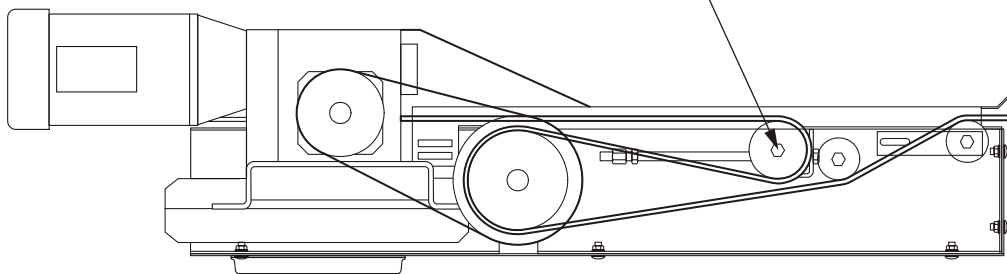

SA8100FKI072a

Figure G - 43 SA2001 Low-Profile Intermediate Drive - Take-Up Adjustment

Adjust both sides equally and in small increments

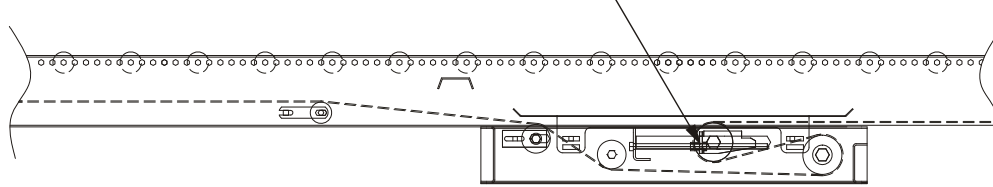

SA8100FKI073a

Figure G - 44 SA2030 Auxiliary (manual) Take-Up Adjustment

Snub Roller Adjustment

The Snub Roller mounting hardware is common for all drives, take-ups, idlers, etc.

To adjust:

1. Loosen the Flange Nut on one side of the conveyor.
2. Move the Adjustment Flat and Snub Roller fore/aft.
3. Re-tighten the Flange Nut when the adjustment is complete.

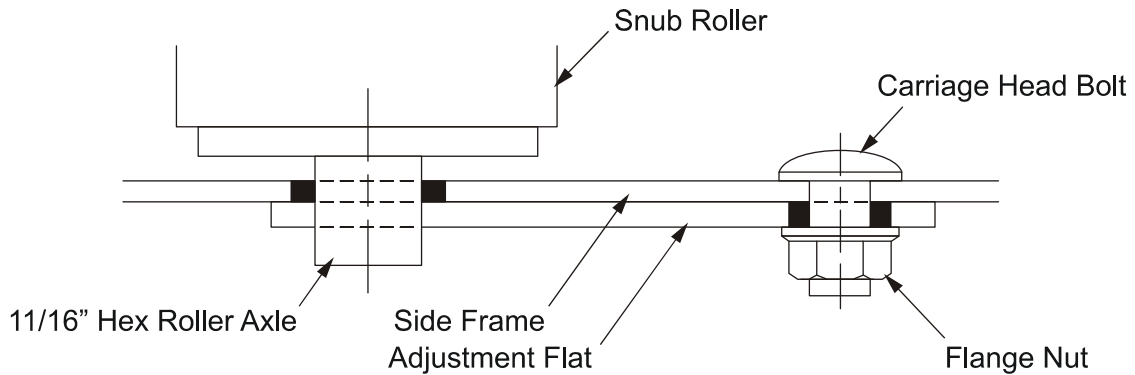

SA8100FKI074a

Figure G - 45 Snub Roller Adjustment

SECTION H: MAINTENANCE

General

The recommended inspection and maintenance functions described in this Section apply to intermittent-duty conveyor applications. Additional functions may be required for continuous-duty operation or extreme environmental conditions.

Maintenance Safety

WARNING: Maintenance must be performed only by qualified personnel who are trained in normal and emergency operations of the conveyor and who are knowledgeable of all safety devices, their locations, and functions.

Before performing maintenance on a conveyor, make certain that the conveyor's power disconnect is locked in the OPEN position and tagged to prevent accidental or unexpected application of power.

Do not perform maintenance while the conveyor is running unless specifically instructed to do so in this manual.

Note: Other than belt tracking, it is NOT necessary to have the conveyor turned ON to perform any of the work described in this section.

Before restarting a conveyor that has been shut down for maintenance:

- Remove all foreign objects from the conveyor.
- Be sure that all guards and safety devices are properly installed and working.
- Make sure that all persons are clear of the conveyor and are aware that the conveyor is about to be restarted.

Safety Precautions

- DO turn off conveyor power source(s) and affix appropriate lockout/tagout device(s) to operating controls before servicing the equipment. ONLY trained and qualified personnel who are aware of the safety hazards should perform equipment adjustments or required maintenance while the conveyor is in operation.
- DO observe all warning signs, lights, and alarms associated with the conveyor operation and maintenance, and be alert at all times to automatic operation(s) of adjacent equipment.
- DO use extreme caution near moving conveyor parts to avoid the hazard of hands, hair, and clothing being caught.
- DO NOT sit on, stand on, walk, ride, or cross (over or under) the conveyor at any time except where suitable catwalks, gates, or bridges are provided for personnel travel.
- DO NOT attempt to repair any equipment while the conveyor is running, replace any conveyor component without appropriate replacement parts, or modify the conveyor system without prior approval by the manufacturer.
- DO NOT operate the conveyor until all safety guards are securely in place, all tools and non-product materials are removed from or near the conveying surfaces, and all personnel are in safe positions.

-
- DO NOT remove or modify any safety devices provided on or with the conveyor.
 - DO NOT clear jams or reach into any unit before first turning off the equipment power source(s) and affixing appropriate lockout/tagout device(s).

New Installations

All newly installed equipment should be inspected frequently and serviced as needed during the first 40 hours of operation. See “Initial Start-up and Run-in Period” on page H - 2. Thereafter, an appropriate maintenance program should be established and followed. See Table H-1.

Maintenance Logs

Maintenance logs should be kept on all conveyor installations. Each log sheet should show:

- The date when an Inspection or Maintenance function was performed;
- details of the Inspection or Maintenance function; and
- names of personnel performing the Inspection or Maintenance function

Initial Start-up and Run-in Period

Chain and Sprockets

Check the drive chain tension daily for the first week of operation, then monthly. Refer to the “Chain Maintenance” label on the inside of chain guard.

WARNING: Chain tension must be checked while the conveyor is running with the chain guard removed. When checking, be careful to stay clear of the chain and drive components.

Power Unit Reducer

The Grove and Reliance reducers are supplied with “lifetime” synthetic lubricants (Mobile SHC-634) that do not need to be changed after the unit is put into service.

Note: All reducers tend to run hot when first put into operation until the maximum break-in efficiency is reached (approximately 120 hours).

Scheduled Inspections and Maintenance

The intervals indicated for performing maintenance in Table H-1 apply to an 8 hour/day operation. An application may subject the equipment to conditions that require more frequent maintenance. This may best be determined by performing maintenance more frequently when the conveyor is first put into operation and then lengthening the intervals as experience suggests.

Table H-1 Scheduled Inspections

Interval	Components	Item Check							
		Lubrication	Oil Level	Tension	Wear	Alignment	Fasteners	Physical	Operation
Daily	General Operation							X	X
	Safety Guards / Devices						X	X	X
Weekly	Belt / Lacing			X	X	X		X	
	Rollers - Carrier / Belt Return							X	X
	Electrical Devices						X	X	X
	General Structure						X	X	X
	Power Unit - Reducer							X	X
Monthly	Bearings - External and Internal							X	X
	Power Unit - Motor and Reducer		X				X	X	X
	Timing Belts and Sprockets			X	X	X	X	X	X
	Drive Chains and Sprockets			X	X	X	X	X	X
	Drive Pulley Lagging				X	X		X	
	Take-Up / Idler Pulleys							X	X
	Supports and Hangers						X	X	

CAUTION: Before performing maintenance on a conveyor, make certain that the conveyor's power disconnect is locked in the open position and tagged to prevent accidental and unexpected application of power.
 Do not perform maintenance while the conveyor is running (exception - belt tracking).
 Maintenance must be performed only by qualified personnel who are trained in normal and emergency operations of the conveyor and who are knowledgeable of all safety devices, their locations and functions.

Daily Inspection

General Operation

Walk through the system and inspect the conveyor equipment during plant operation. For continuous-duty applications, conduct the inspections once every shift.

Any unusual conveyor noise, oil leaks and operational problems should be reported and promptly corrected.

Safety Guards / Devices

Check that the safety guards, warning signs, light and alarms are in place and in proper working condition. Check that all emergency stop pull cords and/or push buttons are functioning properly.

Weekly Inspection

Belting

Check that the belt tracks properly along the entire conveyor length. If the belt mistracks at any point, check edges of belt for wear and/or damage.

Check that belt-tension is sufficient to prevent the belt from slipping on the drive pulley when the conveyor is turned on.

Check for wear on the edges of the belt; and check for buildup of dirt and/or product spillage; clean the belt if necessary.

Belt Lacing

Check the lacing for damage or protrusions which might cause damage to the belt, conveyor, product, or personnel.

If lacing needs to be replaced and the take-up permits, cut both ends of the belt square and re-lace. If the take-up does not permit, cut ends square and lace-in a short length of belting (12" minimum).

Rollers - Carrier, Pressure and Belt Return

Check that all rollers are in place and turning freely. Remove any buildup of dirt and/or product spillage.

Electrical Devices

Inspect, clean and adjust line-status photocells, etc., as needed.

General Structure

Check the conveyor's physical condition, looking for loose fasteners, damaged or worn components, and build-up of dirt and/or product spillage. Listen for unusual noises coming from bearings, motors and reducers.

Check that the conveyed product travels along the length of the conveyor without obstruction.

Power Unit Reducer

Check for signs of oil leakage beneath the reducer. If the leakage persists or the amount of leakage is significant, repair or replace the unit. Closely monitor the oil level until corrections are made.

Monthly Inspection

External Bearings

Check that all mounting bolts, locking collar set screws, etc. are securely tightened and that no lubricant is coming out of the seals. Listen for any unusual noises.

Internal Bearings

Check that the bearings are fully-pressed into the idler/take-up pulleys and that no lubricant is coming out of the seals. Listen for any unusual noises.

Power Unit - Motor

Remove any buildup of dirt/dust around the motor vent openings. Check that all mounting bolts are securely tightened and that the motor lead wires are securely connected.

Power Unit - Reducer

Check the oil level while the unit is warm. If required, add oil through the "fill" hole until the oil begins to run out the "oil level" hole. All standard reducers (Grove and Reliance) are filled by the manufacturer with a synthetic gear lubricant. When replenishing the oil, be sure to use the same brand and type. DO NOT MIX lubricants. For further information, refer to the instruction tag attached to the unit.

To prevent leakage, apply Teflon tape or Permatex to the threads of the fill plug and oil level plug before reinstalling. Properly install and tighten the plugs before putting the conveyor back into operation.

Check that all fasteners are properly tightened.

Timing Belt Sprockets

Check alignment by placing a straight-edge across the face of both sprockets simultaneously.

Timing Belt

Check for wear and/or cracking.

Check tension using the following steps.

1. Measure the "center distance" between the "driver" and "driven" sprockets
2. Use Table H-2 to determine the required deflection based upon the measured center distance (Step 1).

Table H-2 Sprocket Center Distance / Belt Deflection (CD/64)

Center Distance	Deflection	Center Distance	Deflection	Center Distance	Deflection
12.0"	.187"	16.0"	.250"	20.0"	.312"
12.5"	.195"	16.5"	.257"	20.5"	.320"
13.0"	.203"	17.0"	.265"	21.0"	.328"
13.5"	.211"	17.5"	.273"	21.5"	.335"
14.0"	.218"	18.0"	.281"	22.0"	.343"
14.5"	.226"	18.5"	.289"	22.5"	.351"
15.0"	.234"	19.0"	.296"	23.0"	.359"

Center Distance	Deflection	Center Distance	Deflection	Center Distance	Deflection
15.5"	.242"	19.5"	.304"	24.0"	.375"

3. Adjust the fore/aft position of the power unit until the timing belt's "deflection" (Table H-3) is reached with the "force" shown in.

Table H-3 Timing Belt Size / Force

Belt Pitch	Belt Width	Force
8mm	12mm	7 lbs.
	22mm	15 lbs.
	35mm	20 lbs.
14mm	42mm	23 lbs.

When replacing a Timing Belt, be sure that the replacement belt is the same Brand and Type as the belt being replaced.

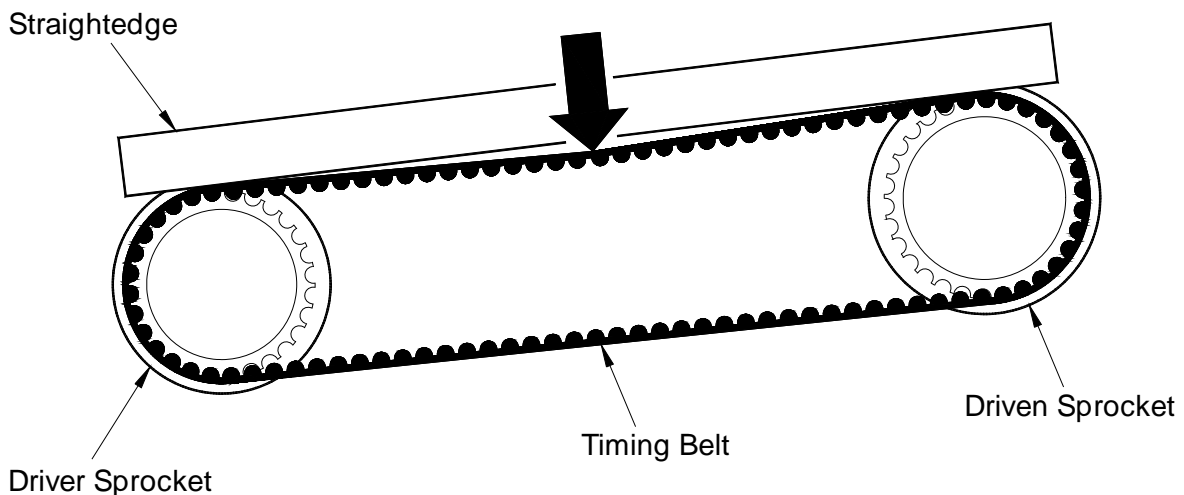

8100FKI013a

Figure H - 1 Check Timing Belt Deflection

Chain Sprockets

- Check for wear of sprocket teeth.
- Check alignment by placing a straight-edge across the face of both sprockets simultaneously.

Chain

- Check for chain wear.
- Check chain tension.
- Remove excessive sag.
- Do not over-tension.

Drive Pulley and Lagging

- Check pulley alignment if belt is not tracking.
- Check mounting bolts are securely tightened.
- Check for worn or damaged lagging. Repair or replace as required.

Troubleshooting

Basic troubleshooting provisions are outlined below. For troubleshooting for the specific conveyor system installed, always check the maintenance information. Basic troubleshooting is outlined in Table H-4.

CAUTION: Do not clear jams or reach into any unit before first turning off the equipment power source(s) and making certain that all moving parts are fully stopped. To avoid personal injury or equipment damage, lockout and tagged the conveyor operation control(s) before attempting to correct any malfunction.

Table H-4 Troubleshooting Problems and Solutions

Problem	Cause	Solution
Conveyor does not start	Electrical power shut-off or control circuit NOT energized.	Check that the system's Control Panel(s) are energized. Be certain that emergency stop devices are not activated.
	System control devices (photo-cells, limit switches, etc.), out of adjustment or defective.	Adjust or replace.
	Motor overload block open.	Check conveyor drive system and overload sizing before resetting.
Conveyor shuts off	Accumulation photo-cell or other control device(s) actuated or defective.	Check conveyor accumulation or obstruction of control device; replace control device if defective.
	Emergency Stop activated.	Correct condition and reset according to control logic.
	Power or component failure at system control center.	Refer to vendor manuals.
	Motor overload.	Check Overload sizing before restarting.
One part of belt creeps to one side.	Belt ends not cut square.	Cut the belt ends "square" using a T-square.
Entire belt creeps to one side	Improper loading of belt.	Center the product on the belt. Load in the direction of travel.
	Belt shifts to low side. The conveyor/base structure not level or is crooked.	Check that the conveyor frame is level and aligned correctly.
	Pulleys and/or rollers not perpendicular to conveyor's centerline.	Check and square pulleys and rollers as required using T-square.
	Buildup of dirt on underside of belt, pulley(s), roller(s) creates a false crown.	Clean belt, pulleys and rollers.

Problem	Cause	Solution
Belt creeps to one side of discharge end of conveyor	Head pulley not square with conveyor frame.	Adjust head pulley (refer to Section G, Belt-Tracking).
Belt creeps to one side at infeed end of conveyor.	Snub Roller at tail pulley not adjusted properly.	Adjust Snub Roller at tail pulley (refer to Section G, Belt Tracking).
Belt wanders irregularly	Off-center loading of product onto conveyor.	Correct loading procedure.
Excessive wear of belt's edges	Belt not traveling down center of conveyor and rubbing against side frame.	Correct belt-tracking issues (refer to Section G, Belt-Tracking).
	Off-center or side loading of product onto conveyor.	Correct loading procedure.
Belt lacing pulls out	Belt lacing incorrectly installed.	Install a new lacing.
	Excessive belt tension.	Reduce belt tension.

SECTION I: PARTS IDENTIFICATION**General Information**

This section covers repair and replacement parts most likely to be needed in the maintenance program of a Power Belt Conveyor.

The purpose of this section is to identify the critical replacement parts required for a solid preventative maintenance program and to minimize the chances for extended down time.

SA2000 - Intermediate Drive

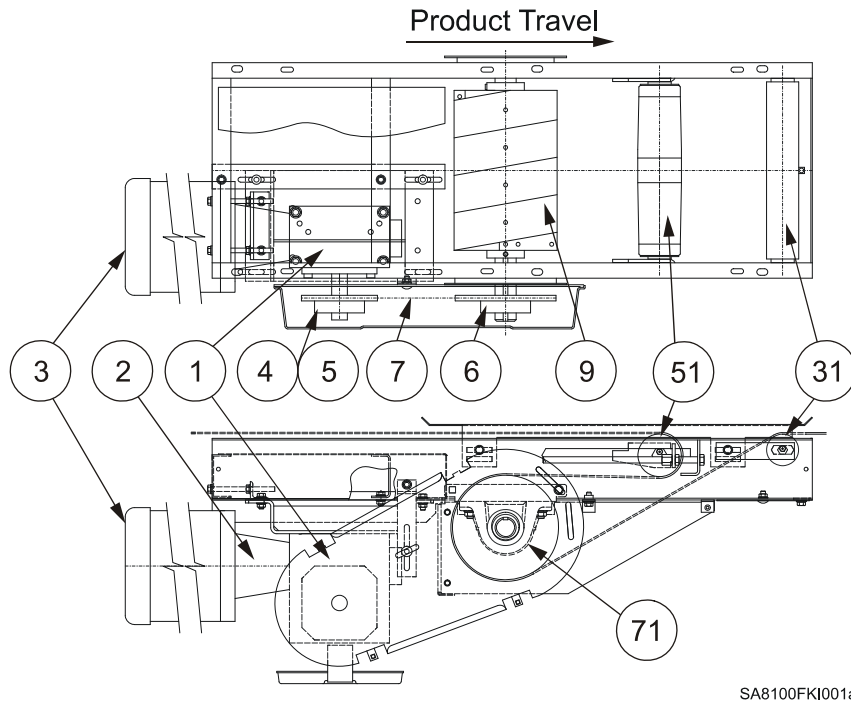

SA8100FKI001a

Figure I - 1 SA2000 - Intermediate Drive (RH Drive Assembly Shown)

SA2001 - Low Profile Intermediate Drive

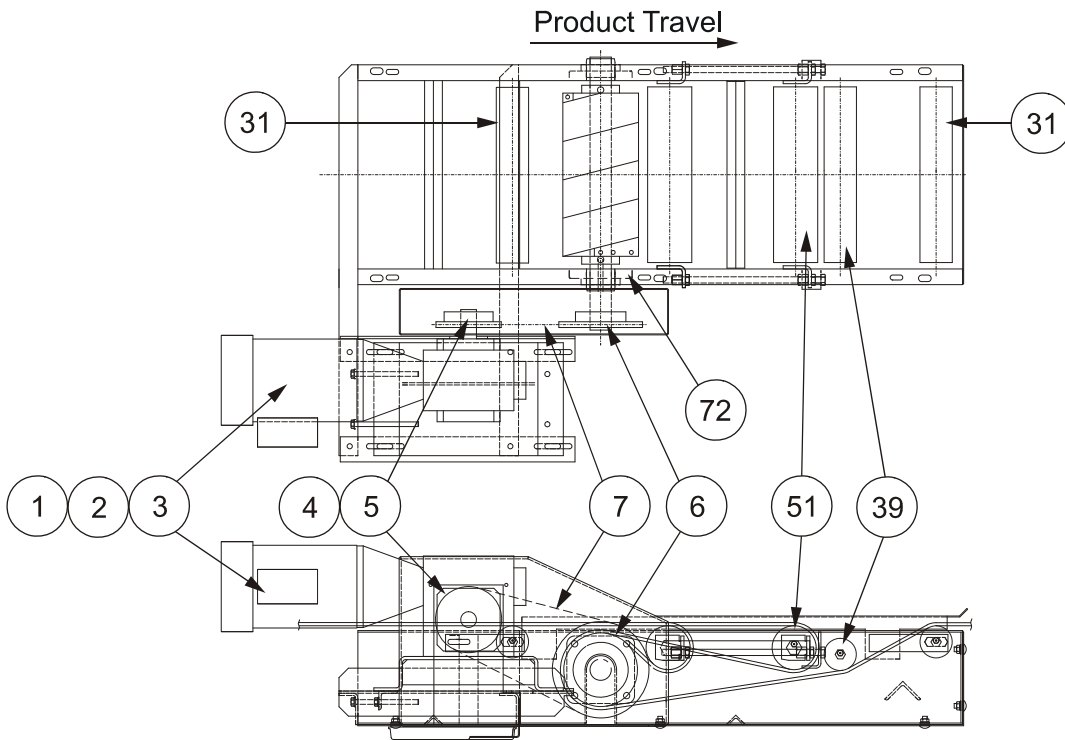

SA8100FKI002a

Figure I - 2 RSA2001 - Low Profile Intermediate Drive (RH Drive Assembly Shown)

SA2030 - End Drive (Channel Frame)
SA2031 - End Drive (Pick Frame High)
SA2032 - End Drive (Pick Frame Low)

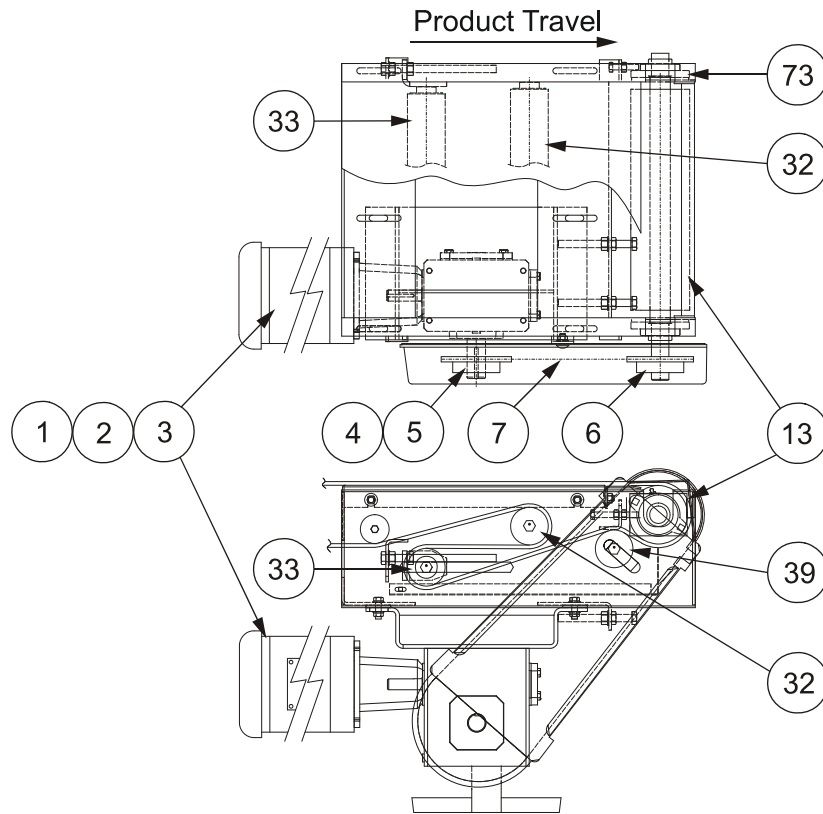

SA8100FKI003a

Figure I - 3 SA2030 - End Drive (Channel Frame - RH Drive Assembly Shown)

SA2033 - End Drive (Channel Frame)

Future Release

Figure I - 4 SA2033 - End Drive (Channel Frame - RH Drive Assembly Shown)

SA2034 - Infeed End Idler
SA2035 - Discharge End Idler

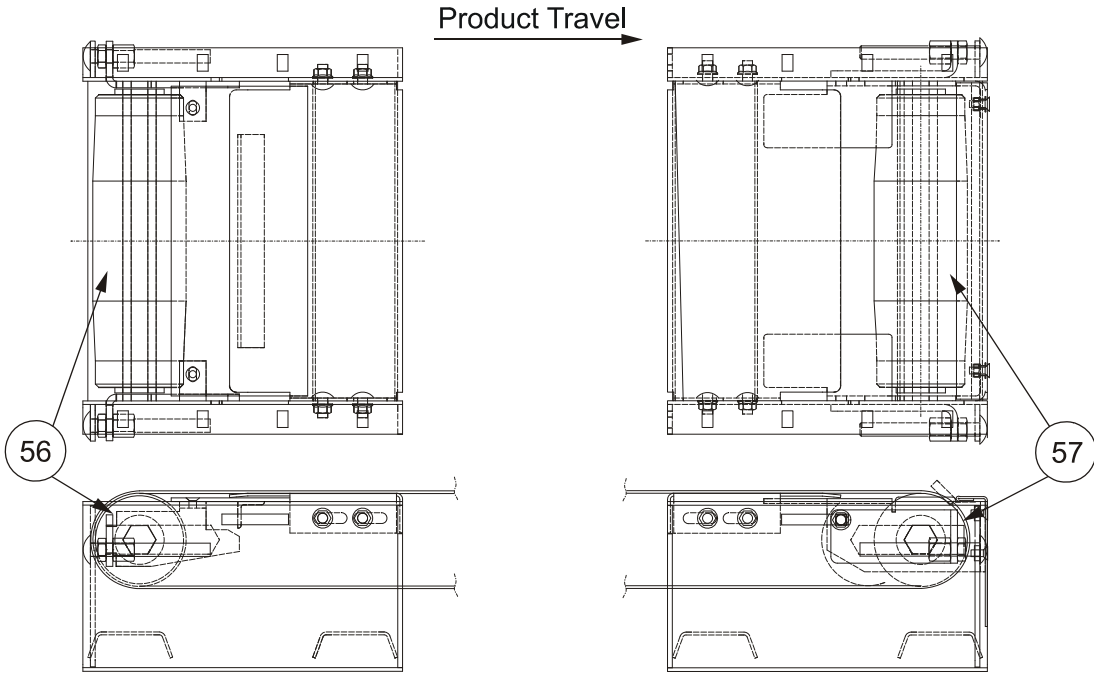

SA8100FKI005a

Figure I - 5 SA2034 Infeed End Idler (Left) and SA2035 Discharge End Idler (Right)

SA2036 - Infeed End Idler - KE
SA2037 - Discharge End Idler - KE

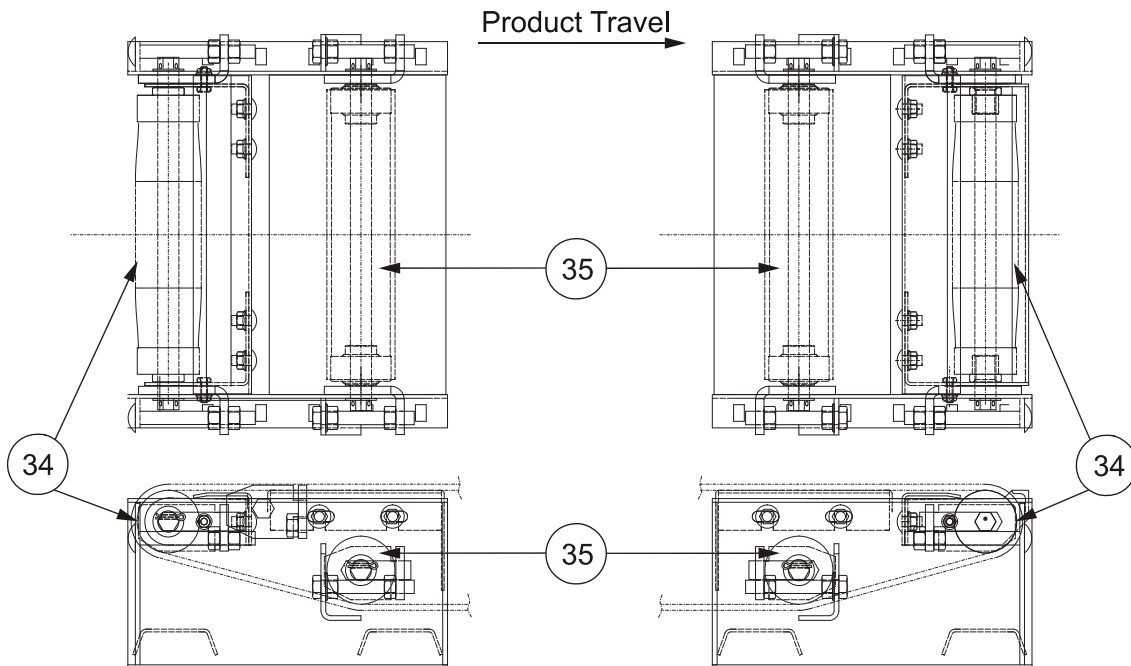

SA8100FKI006a

Figure I - 6 SA2036 Infeed End Idler - KE (Left) and SA2037 Discharge End Idler - KE (Right)

SA2200 - Spring Take-Up

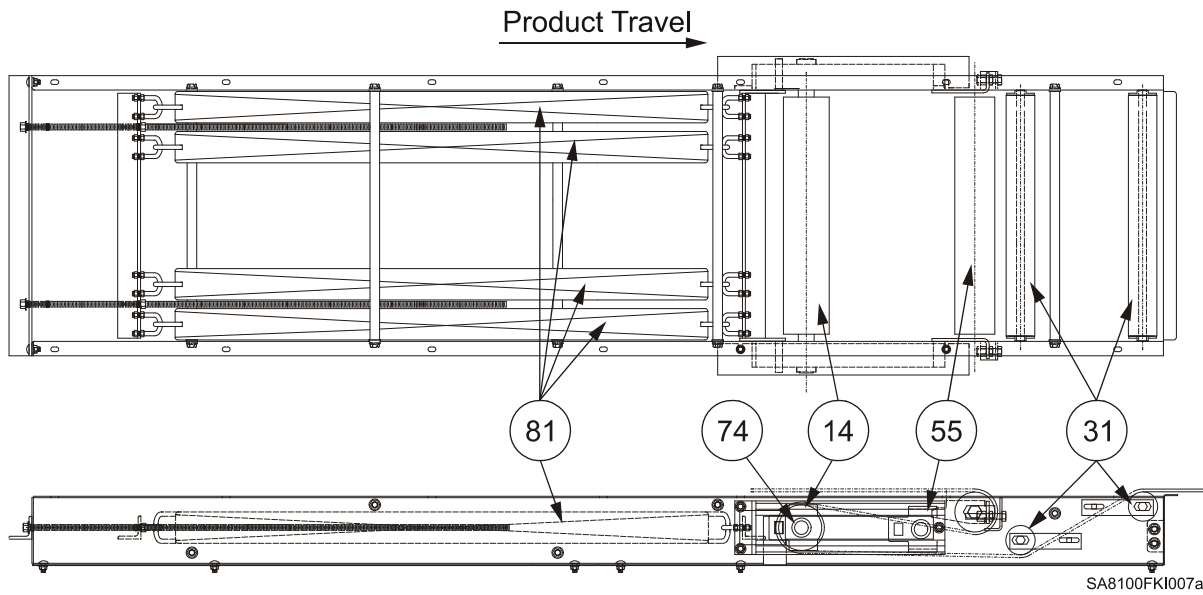

SA8100FKI007a

Figure I - 7 SA2200 - Spring-Type Take-Up

SA2220 - Air Take-Up

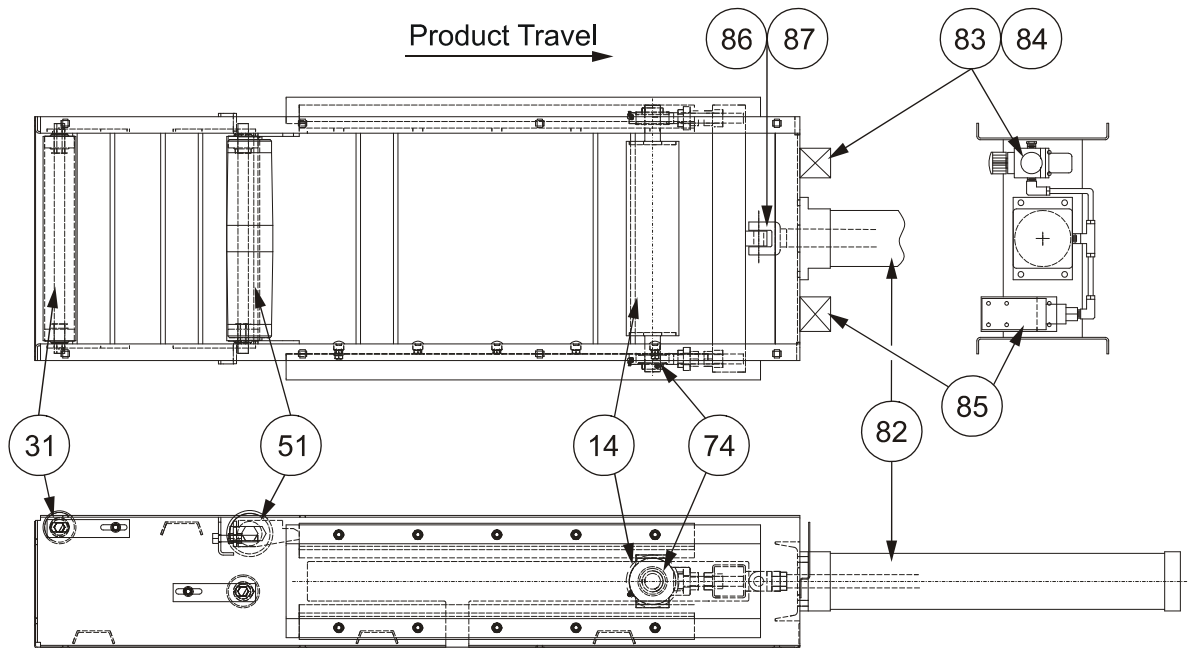

SA8100FKI008a

Figure I - 8 SA2220 - Air Take-Up

SA2300 - Three-Pulley Hitch Transfer

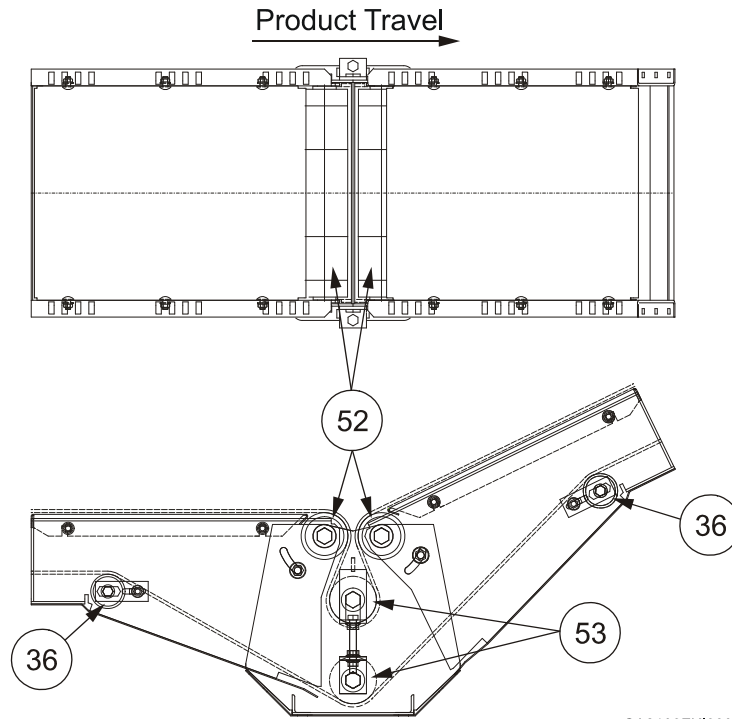

SA8100FK1009a

Figure I - 9 SA2300 - Three-Roller Assembly

SA2301 - Auxiliary Take-Up

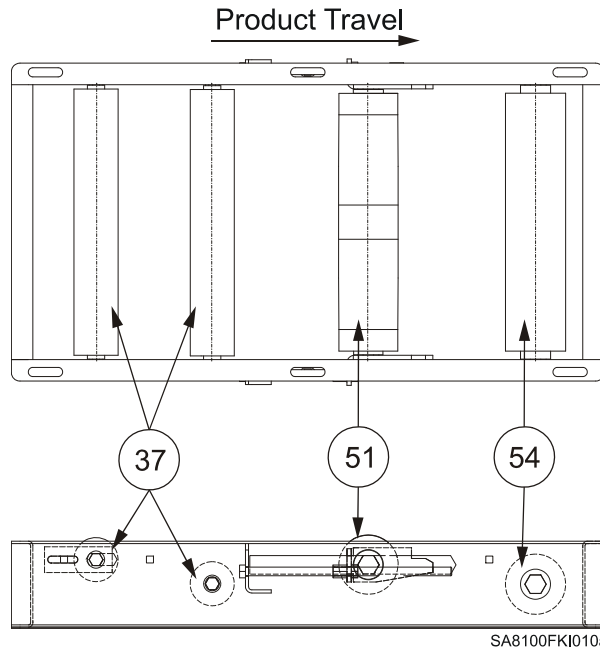

SA8100FK1010a

Figure I - 10 SA2301 - Auxiliary Take-Up

SA2310 - PTO Assembly

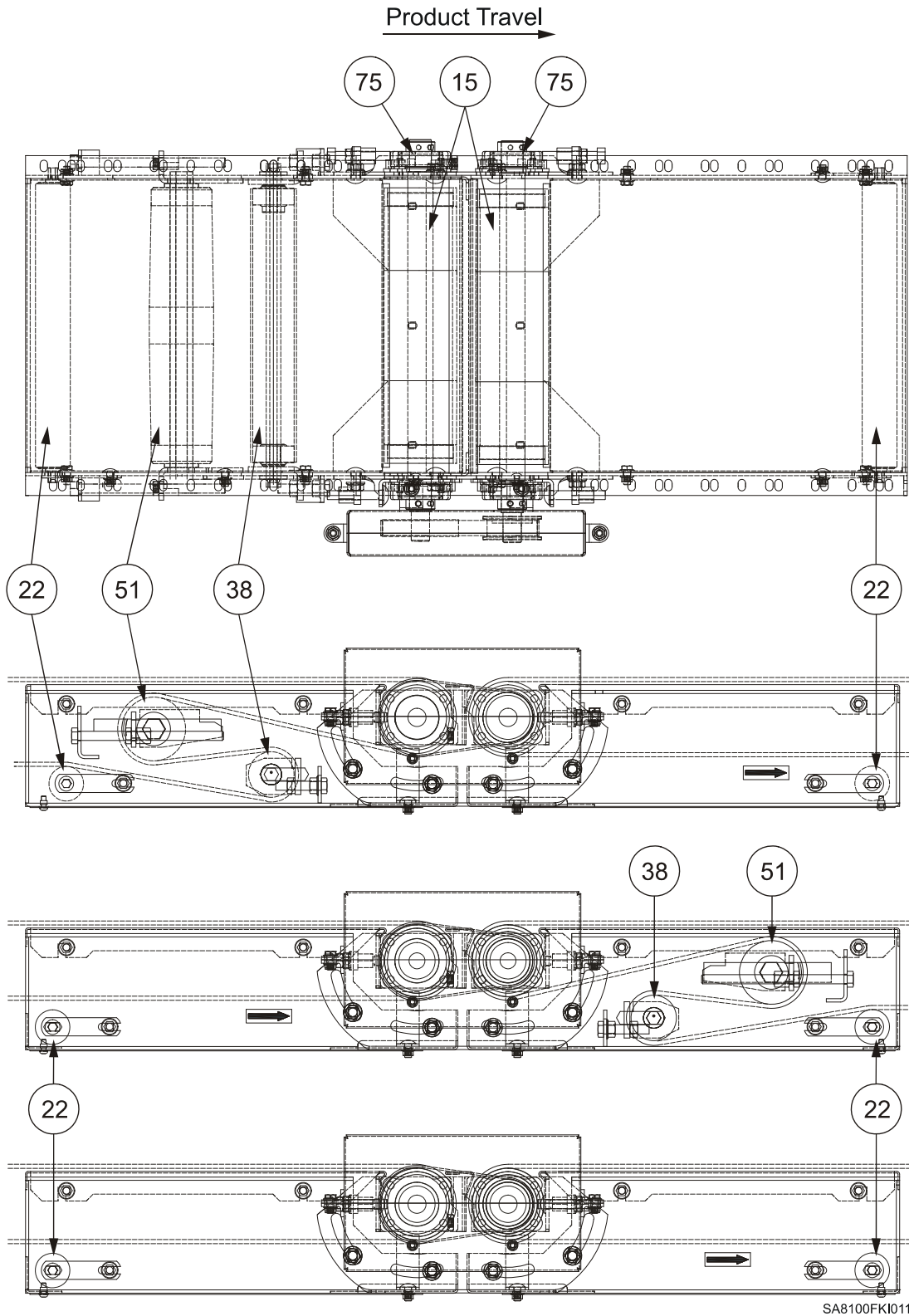

Figure I - 11 SA2310 - PTO Assembly - With Take-Up (Top, Center); Without Take-Up (Bottom)

SA2500 - Intermediate Section (Channel Frame, Roller Bed)
SA2503 - Intermediate Section (Channel Frame, Slider Bed)

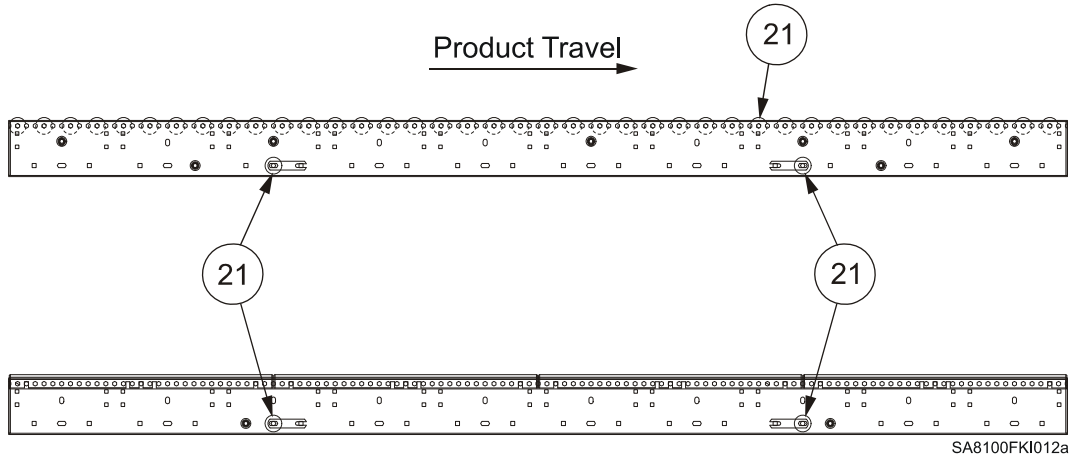

Figure I - 12 SA2500/03 Intermediate Section(s) - Roller Bed (Top); Slider Bed (Bottom)

SA2519 - Upper Bend Assembly

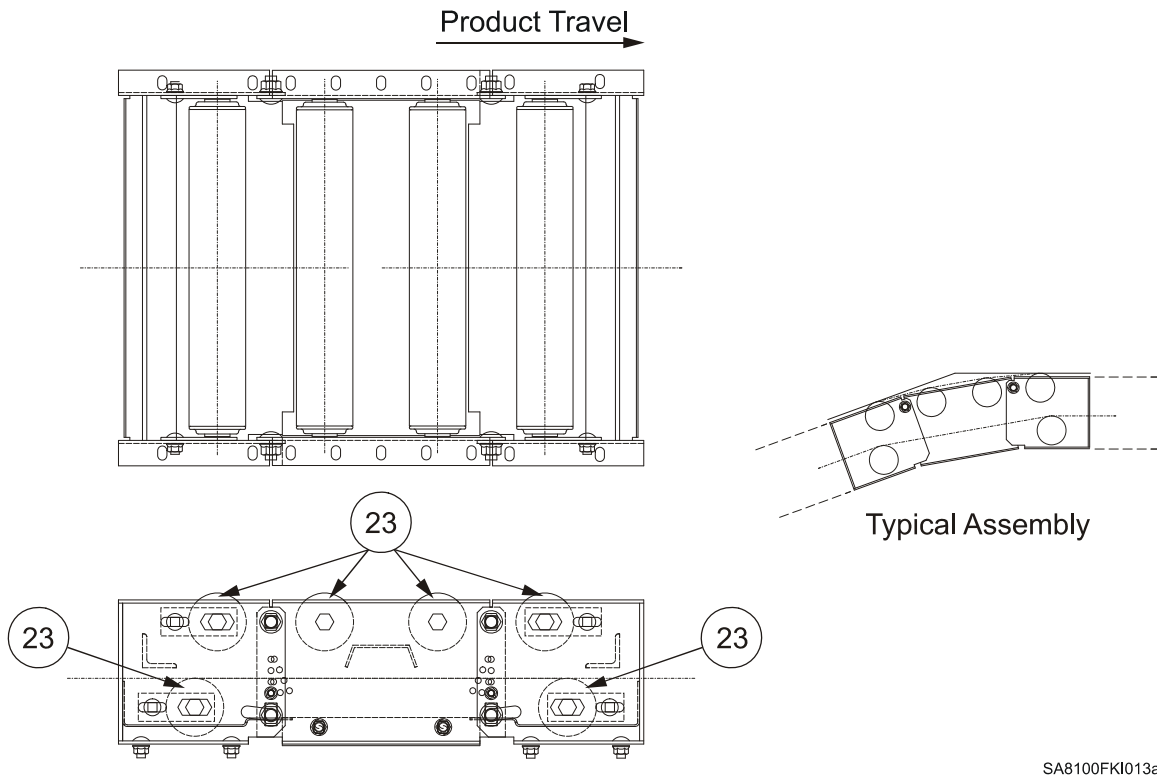

Figure I - 13 SA2519 - Upper Bend Assembly (Typical Unit Installed - Right)

Table I - 1 Parts

Key No	Part Description	Part Number
1	REDUCER, C-face, (Dodge TiGEAR2)	See Table I.2
	REDUCER, C-face, (Grove)	See Table I.3
2	ADAPTOR – Motor / Reducer (for Dodge TiGEAR2 ONLY)	See Table I.4
3	MOTOR, C-face	See Table I.5
4	SPROCKET, DR (Drive/Power Unit and PTO Assembly)	See Table I.6
5	BUSHING (for "DR" Sprocket)	See Table I.7
6	SPROCKET / BUSHING, DN	See Table I.8
7	BELT, Timing	See Table I.9
11	PULLEY, Drive 8.0" Dia., Crowned / Lagged, 1.675" Shaft (SA2000)	See Table I.10a
12	PULLEY, Drive 5.5" Dia., Crowned / Lagged, 1.675" Shaft (SA2001)	See Table I.10b
13	PULLEY, Drive 4.0" Dia., Crowned / Lagged, 1.18" Shaft (SA2030/1/2)	See Table I.10c
14	PULLEY, TU 4.0" Dia., Crowned, 1.375" Shaft (SA2200 / SA2220)	See Table I.10d
15	PULLEY, PTO 4.00"Dia., Crowned / Lagged, 1.187" Shaft (SA2310)	See Table I.10e
21	ROLLER, Carrier / Belt Return, Galv, 1.90" dia.,.487"Hx Shft (SA2500)	See Table I.11
22	ROLLER, Snub / Belt Return, Galv, 1.90" dia.,.487"Hx Shaft (SA2310)	See Table I.11c
23	ROLLER, Carrier / Belt Return, Galv, 2.50" dia.,.675Hx Shaft (SA2519)	See Table I.12
31	ROLLER, Snub, Galv., 2.56" Dia. (SA2000, 2001, 2200, 2220)	See Table I.13
32	ROLLER, Idler/TU, Galv., 2.56" Dia. (SA2030/1/2)	See Table I.14a
33	ROLLER, Snub, Galv., 2.56" Dia. (SA2030/1/2)	See Table I.14b
34	ROLLER, Idler, Galv., 2.37" Dia. KE (SA2036/7)	See Table I.14c
35	ROLLER, Idler, Galv., 2.56" Dia. (SA2036/7)	See Table I.14d
36	ROLLER, Idler, Galv., 2.56" Dia. (SA2300)	See Table I.14e
37	ROLLER, Idler, Galv., 2.56" Dia. (SA2301)	See Table I.14f
38	ROLLER, Take-Up, Galv., 2.56" Dia. (SA2310)	See Table I.14g
39	ROLLER, Take-Up, Galv., 2.56" Dia. (SA2001, 2030/1/2)	See Table I.14h
51	ROLLER, T.U., 3.50" Dia. CRWD (SA2000, 2001, 2220, 2301, 2310)	See Table I.15a
52	ROLLER, Idler, 3.50" Dia. (SA2300)	See Table I.15b
53	ROLLER, Idler, 3.50" Dia. (SA2300)	See Table I.15c
54	ROLLER, Idler, 3.50" Dia. (SA2301)	See Table I.15d
55	ROLLER, Snub, 3.5" Dia. (SA2200)	See Table I.15e
56	ROLLER, Snub, 3.5" Dia. (SA2034)	See Table I.15f
57	ROLLER, Idler, 3.5" Dia. (SA2035)	See Table I.15g
71	BEARING, Pillow Block, non-relube, 1.675" Br (SA2000)	7850979
72	BEARING, Flange, 2-Bolt, non-relube, 1.675" Br (SA2001)	7013194
73	BEARING, Flange, 2-Bolt, non-relube, 1.187" Br (SA2030/1/2)	7001677
74	BEARING, Take-Up, non-relube, 1.187" Br (SA2200, 2220)	7001388
75	BEARING, Flange, 2-Bolt, non-relube, 1.187" Br (SA2310)	7016232
81	SPRING (SA2200)	7030008
82	CYLINDER, AIR, 4.00 BR x 24.00 STRK,PARK (SA2220)	7001428
83	GAGE – 200PSI (SA2220)	7742990
84	FILTER / REGULATOR (SA2220)	7128934
85	PRESSURE SWITCH (SA2220)	7320104
86	CLEVIS (SA2220)	7013205
87	CLEVIS PIN (SA2220)	7126424
88	PAINT, FKI Logistex Satin Gray (Spray Can)	7900005
Not Shown	BELTING	See Tables I-16, 20
	LACING	See Table I-21
	LACING PIN	See Table I-22

Table I - 2 Dodge TiGEAR2 Reducer Part Numbers Output Shaft Diameter (OD)

Ratio	Model 175		Model 200		Model 230		Model 260	
	.875" Shaft O.D.		1.0" Shaft O.D.		1.125" Shaft O.D.		1.25" Shaft O.D.	
	R* (SHN)	L* (OPP)	R* (SHN)	L* (OPP)	R* (SHN)	L* (OPP)	R* (SHN)	L* (OPP)
5:1	7034690	7034689	7015847	7027611	7034687	7034686	7034311	7034310
7.5:1	7017689	7017688	7034683	7034682	7034308	7034309	7034317	7034316
10:1	7034688	7017464	7034691	7017448	7034685	7034684	7034295	7034294
15:1	7017526	7017567	7016321	7017774	7017577	7017734		
20:1	7017518	7017587	7017455	7017782	7017513	7017515	7034301	7034300
25:1	7019728	7017586	7027103	7017460	7017454	7017584	7034303	7034302
30:1	7068952	7068953	7027019	7027018	7017739	7017737	7034305	7034304
40:1			7027612	7027613	7027614	7027615	7034307	7034306
50:1			7019803	7019802	7027616	7027617	7034313	7034312
60:1					7068954	7068955	7034315	7034314
Ratio	Model 300		Model 350					
	1.375" Shaft O.D.		1.875" Shaft O.D.					
	R* (SHN)	L* (OPP)	R* (SHN)	L* (OPP)				
5:1			7034329 7034328					
7.5:1	7034693	7034692	7068956 7068957					
10:1	7017465	7017531	7034319 7034318					
15:1	7017527	7017529	7034321 7034320					
20:1	7034627	7017573	7034323 7034322					
25:1	7019676	7019677	7034325 7034324					
30:1	7019638	7019639	7034327 7034326					
40:1	7015955	7017467						
50:1			7034331 7034330					
60:1	7019710	7019711	7034333 7034332					

*Dodge Reducer Assembly "R"

- For (SHN) SA2000 Intermediate Drive (Figure I-1) w/RH Power Unit mounting (near side).
- For (SHN) SA2030/1/2 End Drives (Figure I-3) w/RH Power Unit mounting (near side).
- For (OPP) SA2001 LP Intermediate Drive (Figure I-2) w/LH Power Unit mounting (far side).

**Dodge Reducer Assembly "L"

- For (OPP) SA2000 Intermediate End Drive (Figure I-1) w/ LH Power Unit mounting (far side).
- For (OPP) SA2030/1/2 End Drives (Figure I-3) w/ LH Power Unit mounting (far side).
- For (SHN) SA2001 LP Intermediate Drive (Figure I-2) w/RH Power Unit mounting (near side).

Table I - 3 Grove Reducer Parts Numbers / Output Shaft Diameter (OD)

Motor Frame	Model 220		Model 224		Model 226	
	1.0" Shaft O.D.		1.125" Shaft O.D.		1.25" Shaft O.D.	
	3* (SHN)	2** (OPP)	3* (SHN)	2** (OPP)	3* (SHN)	2** (OPP)
5:1 Reducer Ratio						
56C	7005804	7005805	7012589	7012588	--	--
140C	7005806	7005141	7005809	7005810	--	--
180TC	7005807	7005808	7005035	7005811	7005021	7030474
213TC						
7.5:1 Reducer Ratio						
56C	7005815	7005025	7009699	7017638	7027715	7027714
140C	7005159	7005027	7005816	7005036	7030473	7030472
180TC			7005818?	7005818	7905502	7905505
213TC						
10:1 Reducer Ratio						
56C	7005223	7005312	7005829	7005052	7031010	7031017
140C	7005827	7005828	7005830	7005831	7030471	7030470
180TC	--	--	--	--	7005157	7005156
213TC	--	--	--	--	--	--
15:1 Reducer Ratio						
56C	7005221	7005840	7005037	7005158	7031014	7031016
140TC	7005033	7005841	7005038	7005032	7005086	7005030
180TC	--	--	--	--	--	--
20:1 Reducer Ratio						
56C	7005850	7005851	7005852	7005853	7031012	7031011
145TC	7026055	7026054	7005854	7005333	7005081	7005080
180TC	--	--	--	--	--	--
25:1 Reducer Ratio						
56C	7005860	7005861	7005862	7005863	7031015	7031011
145TC	--	--	7005864	7005865	7005079	7005078
180TC	--	--	--	--	--	--
30:1 Reducer Ratio						
56C	7009464	7009536	7005870	7005873	7005069	7005068
145TC	--	--	7011739	7068958	7005077	7005076
180TC	--	--	--	--	--	--
40:1 Reducer Ratio						
56C	7005877	7005878	7005879	7005328	7005065	7005064
145TC	--	--	--	--	7068959	7010163
180TC	--	--	--	--	--	--
50:1 Reducer Ratio						
56C	7007218	7010955	7005885	7005886	7005063	7005062
145TC	--	--	--	--	--	--
180TC	--	--	--	--	--	--
60:1 Reducer Ratio						
56C	7005891	7005892	7005893	7005894	7005061	7005060
145TC	--	--	--	--	--	--
180TC	--	--	--	--	--	--

Table I - 3 Grove Reducers (continued)

Motor Frame	Model 230		Model 232		Model 242	
	1.??” Shaft O.D.		1.??” Shaft O.D.		1.??” Shaft O.D.	
	3* (SHN)	2** (OPP)	3* (SHN)	2** (OPP)	3* (SHN)	2** (OPP)
5:1 Reducer Ratio						
56C	--	--	--	--	--	--
140C	--	--	--	--	--	--
180TC	7005039	7005812	--	--	--	--
213TC	7005813	7005814	--	--	7068960	7068961
7.5:1 Reducer Ratio						
56C	--	--	--	--	--	--
140C	--	--	--	--	--	--
180TC	7005819	7005820	7068962	7068963	--	--
213TC	--	--	7005821	7005822	7005823	7005824
10:1 Reducer Ratio						
56C	--	--	--	--	--	--
140C	--	--	--	--	--	--
180TC	7005832	7005833	7030068	7030069	7005834	7005835
213TC	--	--	7068964	7029780	7005836	7005837
15:1 Reducer Ratio						
56C	7068965	7009639	7015123	7026635	--	--
140C	7012567	7068966	7031063	7031064	--	--
180TC	7005142	7005731	7005092	7005091	7005844	7005845
213TC	--	--	--	--	7005846	7005847
20:1 Reducer Ratio						
56C	7005760	7005761	7012659	7068967	7068970	7068971
140C	7005791	7025040	7030647	7031018	7068968	7068969
180TC	7005855	7005320	7005090	7005089	7005856	7005857
25:1 Reducer Ratio						
56C	7009436	7009286	7068972	7068973	7068976	7068977
140C	7005866	7005867	7005085	7005084	7068974	7068975
180TC	--	--	7005088	7005087	7009048	7009047
30:1 Reducer Ratio						
56C	7005871	7005872	7005873	7005784	7009046	7009045
140C	7065810	7009727	7005083	7005082	7005882	7005875
180TC	--	--	--	--	7005766	7005876
40:1 Reducer Ratio						
56C	7005880	7005881	7009652	7019617	7009043	7009285
140C	7010964	7068978	7005075	7005074	7005882	7005883
180TC	--	--	--	--	7005321	7005884
50:1 Reducer Ratio						
56C	7024540	7017483	7031056	7031057	--	--
140C	7011738	7010121	7005073	7005072	7005889	7005890
180TC	--	--	--	--	--	--
60:1 Reducer Ratio						
56C	7005895	7005896	7005067	7005066	7068980	7068981
140C	7009694	7068979	7005071	7005070	7005897	7005898
180TC	--	--	--	--	--	--

*Grove Reducer Assembly “3”

- For (SHN) SA2000 Intermediate Drive (Figure I-1) w/RH Power Unit mounting (near side).
- For (SHN) SA2030/1/2 End Drives (Figure I-2) w/RH Power Unit mounting (near side).
- For (OPP) SA2001 LP Intermediate Drive (Figure I-3) w/LH Power Unit mounting (far side).

**Grove Reducer Assembly “2”

- For (OPP) SA2000 Intermediate End Drive (Figure I-1) w/ LH Power Unit mounting (far side).
- For (OPP) SA2030/1/2 End Drives (Figure I-2) w/ LH Power Unit mounting (far side).
- For (SHN) SA2001 LP Intermediate Drive (Figure I-3) w/RH Power Unit mounting (near side).

Table I - 4 ADAPTOR - Motor / Reducer (Dodge TiGEAR2 ONLY) Part Numbers

Motor Frame	Reducer Size (Dodge TiGEAR2)					
	175	200	230	260	350	350
56C	7037217	7034217	7034218	7034218	7034218	7034219
140TC	7034220	7034220	7034221	7034221	7034221	7034222
180TC	--	7034223	7034223	7034223	7034223	7034224
210TC	--	--	--	--	--	7017308

Table I - 5 MOTOR / BRAKE-MOTOR Part Numbers

HP / Frame	Motor - Standard-Efficiency				Motor - Premium-Efficiency			
	208-230/460 VAC		575VAC		230/460 VAC		575VAC	
	Baldor	Reliance	Baldor	Reliance	Baldor	Reliance	Baldor	Reliance
0.5 HP, 56C	7155562	7177372	7717583	7002088	7002040	7830000	7002060	7002092
0.75 HP, 56C	7150592	7704081	7717584	7002089	7002041	7001615	7002061	7002093
1.0 HP, 56C	7742139	7169146	7717598	--	7002042	7888099	7002062	7002094
1.5 HP, 56C	7778225	7754993	7331614	--	7002043	--	--	--
1.5 HP, 143TC	--	--	--	--	--	7001632	7002063	7002095
2.0 HP, 56C	7274611	7774205	7763322	--	--	--	--	--
2.0 HP, 145TC	--	7704285	--	--	7002044	7001617	7002064	7002096
3.0 HP, 182TC	7747525	7001607	7362599	--	7002045	7001633	7002065	7002097
5.0 HP, 182TC	7747294	7001608	7866559	--	7002046	7001618	7002066	7002098
7.5 HP, 213TC	7329946	7001609	7005793	--	7002047	7001619	7002067	7002099
HP / Frame	Standard Efficiency Brake-Motor							
	230/460 VAC				575VAC			
	Baldor		Reliance		Baldor		Reliance	
	B1*	B2**	B1*	B2**	B1*	B4***	B1*	B4***
0.5 HP, 56C	7742489	7002150	--	7709190	--	7002180	--	--
0.75 HP, 56C	7150962	7002151	--	7704084	7152666	7002181	--	7002090
1.0 HP, 56C	7716179	7002152	--	7172635	--	7002182	--	7002091
1.0 HP, 145C	--	--	--	--	7177586	--	--	--
1.5 HP, 56C	7716197	--	--	7001611	--	--	--	--
1.5 HP, 145C	--	7002153	--	--	--	7002183	--	--
2.0 HP, 56C	7325286	--	--	--	--	--	--	--
2.0 HP, 145TC	--	7002154	--	7704091	--	7002184	--	--
3.0 HP, 182TC	7747295	7002155	--	7704708	--	7002185	--	--
5.0 HP, 182TC	7817618	7002156	--	7001612	--	7002186	--	--
7.5 HP, 213TC	7005792	7002157	--	7001613	--	7002187	--	--
HP / Frame	Premium Efficiency Brake-Motor							
	230/460 VAC				575VAC			
	Baldor		Reliance		Baldor		Reliance	
	B1*	B2**	B1*	B2**	B1*	B4***	B1	B4***
0.5 HP, 56C	7002030	7002050	--	7001621	7002070	7002080	--	7002101
0.75 HP, 56C	7002031	7002051	--	7001622	7002071	7002081	--	7002102
1.0 HP, 56C	7002032	7002192	--	7001623	7002072	7002082	--	1002103
1.5 HP, 145TC	7002033	7002193	--	7001625	7002073	7002083	--	7002104
2.0 HP, 145TC	7002034	7002054	--	7001626	7002074	7002084	--	7002105
3.0 HP, 182TC	7002035	7002055	--	7001627	7002075	7002085	--	7002106
5.0 HP, 182TC	7002036	7002189	--	7001628	7002076	7002086	--	7002107
7.5 HP, 213TC	7002037	7002057	--	7001629	7002077	7002087	--	7002108

(*) B1 = Brake-Motor with Brake Coil wired into Motor

(**) B2 = Brake-Motor with Brake Coil wired separate from the Motor (208-230/460 Volt Coil)

(***) B4 = Brake-Motor with Brake Coil wired separate from the Motor (575 Volt Coil)

Table I - 6 SPROCKET - Driver (DR) - Part Numbers
(For SA2000, SA2001, SA2030/31/32 Drives and SA2310 PTO Assemblies)

TIMING-BELT DRIVE				
Sprocket Teeth (mm)	For Timing Belt Width (mm) / Tooth Pitch (mm)			
	21mm / 8mm	21mm** / 8mm	36mm / 8mm	37mm / 14mm
28	7901066*	--	--	7001566
29	--	--	--	7001567
30	7001533*	--	--	7001568
31	--	--	--	7001569
32	7001534*	--	7001551	7001570
33	--	--	--	7001571
34	7001535*	--	7001552	7001572
35	--	--	--	7001573
36	7001536*	7004712**	7001553	7001574
37	--	--	--	7001575
38	7001537	7004713**	7001554	7001576
39	--	--	--	7001577
38	7001538	7004714**	7001555	7001578
42	7001539	7004715**	7001556	--
43	--	--	--	7001579
45	7001540	--	7001557	7001580
48	7001541	--	7001558	7001581
50	7001542	--	7001559	7001582
(*) Pulley w/Flanges in SA2000, SA2001, SA2030/31/32 Drive/Power Units, & SA2310 PTO Assembly(s)				
(**) Pulley w/No Flange in SA2310 PTO / Transfer Drive Assembly(s) ONLY				
CHAIN DRIVE				
Sprocket Teeth	RC50 (SA2310)	RC50 (SA2030/31/32)	RC60 (SA2000-2001)	
14	7717403	--	--	
15	7123506	--	7732427	
16	7123512	7123512	7788120	
17	7123513	7123513	7124945	
18	7842559	--	7756828	
19	--	7123753	7742721	
20	7841353	7841353	7743918	
21	7762837	7762837	7120512	
22	--	7717408	7000092	
23	--	7762837	7125294	
25	--	--	7730801	

Table I - 7 BUSHING (DR Sprocket) - Part Numbers

Model	Bore							
	0.875"	1.000"	1.125"	1.250"	1.375"	1.500"	1.750"	1.875"
1108	7115206	7001513	7115205	--	--	--	--	--
1210	7200559	7200560	7115208	7115207	--	--	--	--
1610	7717366	7115210	7115213	7115223	7749058	7732428	--	--
2012	7165575	7115235	7115228	7115227	7115232	7721059	--	7115234
2517	--	--	--	--	7009979	7756668	--	7174980
3020	--	--	--	--	7015940	7001528	--	--

Table I - 8 DRIVEN (DN) SPROCKET / BUSHING Part Numbers

TIMING-BELT DRIVE							
Drive	Sprocket				Bushing.		
	Pitch (mm)	Width (mm)	Teeth	Part No	Model	Bore	Part No.
SA2000	8	21	80	7001550	2517	1.68"	7115239
			75	7001549			
			71	7001548			
	36	80	7001565	3020	1.68"	7000084	
		75	7001564	2517	1.68"	7115239	
		71	7001563				
	14	37	56	7001584	3525	1.68"	7000085
			53	7001583	3020	1.68"	7000084
			50	7001582			
SA2001	8	21	63	7001546	2012	1.68"	7115238
			60	7001545	2012	1.68"	7115238
			56	7001544	2012	1.68"	7115238
			50	7001542	2012	1.68"	7115238
			40	7001538	2012	1.68"	7115238
	36	63	7001561	2517	1.68"	7115239	
		60	7895879	2517	1.68"	7115239	
		56	7895878	2012	1.68"	7115238	
		50	7001559	2012	1.68"	7115238	
		40	7001555	2012	1.68"	7115238	
	14	37	48	7001581	3020	1.68"	7000084
			45	7001580	3020	1.68"	7000084
			40	7001578	3020	1.68"	7000084
SA2030,1,2	48	21	8	7001541	2012	1.18"	7115238
	45	21	8	7001541	2012	1.18"	7115230
	42	21	8	7001539	2012	1.18"	7115230
	40	21	8	7001538	2012	1.18"	7115230
	38	21	8	7001537	1610	1.18"	7115214
	36	21	8	7001536	1610	1.18"	7115214
	34	21	8	7001535	1610	1.18"	7115214
	32	21	8	7001534	1610	1.18"	7115214
CHAIN DRIVE							
Drive	Sprocket			Bushing			
	Teeth	Chain Size	Part No	Model	Bore	Part No.	
SA2000	32	RC-60	7742328	2012	1.68	7115238	
SA2001	26	RC-60	7717361	2012	1.68	7115238	
SA2030/1/2	19	RC-50	7123753	1610	1.18	7115214	

Table I - 9 TIMING BELT / DRIVE CHAIN - Part Numbers

Timing Belt Length (mm)	Timing Belt Width / Tooth Pitch		
	21mm / 8mm	36mm / 8mm	37mm / 14mm
TIMING BELT (SA2000, SA2001, SA2030/1/2 – DRIVE / POWER UNIT*)			
896	7001501	7001509	--
1000	7001502	7001510	--
1120	7001503	--	7001516
1190	--	--	7001517
1200	7001504	7001512	--
1260	--	--	7001518
1280	7001506	7001514	--
1400	--	--	7001519
(*) See Table I-__ for Timing Belt Requirements			
TIMING BELT (SA2310 PTO ASSEMBLY)			
544	7027844	--	--
DRIVE CHAIN			
RC50		RC60	
RC50 Riveted	7301050	RC60 Riveted	7301060
RC50 Connector Link	7311050	RC60 Connector Link	7311060
RC50 Offset Link	7312050	RC60 Offset Link	7312060

Table I - 10 PULLEY w/SHAFT - Part Numbers

Description	Conveyor Width W - Part Number				
	16"	22"	28"	34"	40"
a PU, 8.0" x .134", "W", RL, 1.68 Shaft	7005177	7005179	7005008	7005181	7005183
b PU, 5.5" x .____", "W", RL, 1.68 Shaft	7005289	7005291	7005004	7005293	7005295
c PU, 4.0" x .____", "W", RL, 1.18 Shaft	7009386	7009389	7009392	7009395	7009398
d PU, 4.0", ____", "W", 1.375 Shaft	7025521	7025524	7025527	7025530	7025533
e PU, 4.0", ____", "W", 1.18 Shaft	7025421	7025424	7025427	7025430	7025433

Table I - 11 ROLLER 1.9" Dia. Carrier / Belt Return - Part Numbers

Description		Conveyor Width W - Part Number				
		16"	22"	28"	34"	40"
a*	RLR G196 GH P 01 __, __ NC	7017540	7017541	7017542	7017543	7017544
b*	RLR G196 A1 P 01 __, __ NC	7015687	7015688	7015689	7015690	7015691
c*	RLR G196 C1 P 01 __, __ NC	7012584	7012585	7004180	7012586	7012587

*Roller Description Explanation

(Example) RLR G196 GH P 01 16.00 NC

RLR = Roller
 G = (Roller Tube Material/Finish) Galvanized Steel
 196 = (Roller Tube) 1.90" dia x 16 gage (.065" wall)
 GH = (Bearing Type) Greased, Commercial Bearing
 A1 = (Bearing Type) ABEC Precision Bearing
 P = Plain Steel Axle
 01 = Spring-Loaded Axle; Fixed Roller w/o Grooves
 16.00 = Conveyor Width "W"
 NC = No Cover

Table I - 12 ROLLER 2.5" Dia. Carrier / Belt Return - Part Numbers

Description	Conveyor Width W - Part Number				
R/A 2.50x.120,W,S7C	7024781	7024784	7024787	7024790	7024793

Table I - 13 ROLLER 2.56" Dia. Snub - Part Numbers

Description	Conveyor Width – W				
	16"	22"	28"	34"	40"
RO, 2.56x.180 "W" B1151-2REV	7005192	7005193	7005011	7005194	7005195
AX, .687HEX,"W",.313FR,CC	7005196	7005197	7005012	7005198	7005199

Table I - 14 ROLLER / AXLE 2.56" / 2.375" Dia. Take-Up / Idler - Part Numbers

Description	Conveyor Width – W				
	16"	22"	28"	34"	40"
a R/A 2.56x.180 "W" B1151-LT	--	7009350	7009351	7009352	7009353
	RO 2.56x.180 "W" B1151-2REV	7005192	--	--	--
	AX, .687HEX,"W",.125FR,CC	7005296	--	--	--
b R/A 2.56x.180 "W" B1151-LT	--	7009360	7009361	7009362	7009363
	RO 2.56x.180 "W" B1151-2REV	7009355	--	--	--
	AX, .687HEX,"W",.625FR,CC	7009354	--	--	--
c RO 2.375x.300, "W" KNIFE-EDGE	7065006	7065009	7065012	7065015	7065019
	AX, .687HEX,"W", END TAP	7065052	7029657	7025379	7029658
d RO 2.56x.180 "W" L7B, REV	7009355	7061011	7061012	7065042	7065048
	AX, .687HEX,"W",.END TAP	7065052	7029657	7025379	7029658
e RO 2.56x.180 "W" L7B	7005192	7005193	7005011	7005194	7005195
	AX, .687HEX,"W",.438	7024682	7024685	7024688	7024691
f RO 2.56x.180 "W", L7B,REV	7005192	7005193	7005011	7005194	7005195
	AX, .687HEX,"W",.375	7005420	7005421	7005422	7005423
g R/A 2.56, "W", B1151-2REV	--	7061125	7061129	7069078	7069079
	RO 2.56x.180 "W" B1151-2REV	7009355	--	--	--
	AX, .687HEX,"W",.125FR,CC	7069080	--	--	--
h RO 2.56x.180 "W" B1151-2REV	7005192	7005193	7005011	7005194	7005195
	AX, .687HEX,"W",.313FR,CC	7005296	7005297	7005045	7005298

Table I - 15 ROLLER / AXLE 3.50" Dia. Take-Up / Snub - Part Numbers

Description	Conveyor Width – W				
	16"	22"	28"	34"	40"
a RO, CRWD,3.50 x.30, "W" B1106-2	7005184	7005185	7005009	7005186	7005187
	AX, 1.06HEX,"W",PE	7005188	7005189	7005010	7005190
b RO, CRWD,3.50 x.30, "W". L7C	7005400	7005401	7005402	7005403	7005404
	AX, 1.06HEX,"W",PE	7024680	7024683	7024686	7024689
c RO, 3.50 x.30, "W" L7C	7024621	7024624	7024627	7024630	7024633
	AX, 1.06HEX,"W",.687	7024681	7024684	7024687	7024690
d RO, 3.50 x.30, "W". L7C	7005460	7005461	7005462	7005463	7005464
	AX, 1.06HEX,"W",.125FR,CC	7005697	7005698	7005699	7005700
e RO, CRWD, 3.50, "W" B1160-2	7005184	7005185	7005009	7005186	7005187
	AX, 1.06HEX,"W", PE	7005188	7005189	7005010	7005190
f RO, CRWD, 3.50, "W" B1160-2	7009229	7009230	7009231	7009232	7009233
	AX, 1.06HEX,"W", PE	7005188	7005189	7005010	7005190
g RO CRWD, 3.50, "W" B1160-2	7009229	7009230	7009231	7009232	7009233
	AX, 1.06HEX,"W",.PE	7009996	7009999	7015776	7015779

Belting may be either ordered in a standard incremental length roll (see Table I-16); or cut to the length required for the conveyor's specific style and Intermediate Section length (see Tables I-17 – I-20).

Table I - 16 BELT (Roll) Part Numbers

Description / Roll Length		Conveyor Width – W				
		16"	22"	28"	34"	40"
		Belt Width				
		12"	18"	24"	30"	36"
SD2500 – Friction-Surface	25'-0"	7905860	7905900	7905940	7905980	7069087
	50'-0"	7905861	7905901	7905941	7905981	7061627
	75'-0"	7905862	7905902	7905942	7905982	7014460
	100'-0"	7905863	7905903	7905943	7905983	7014461
	125'-0"	7905864	7905904	7905944	7905984	7069088
	150'-0"	7905865	7905905	7905945	7905985	7014462
	175'-0"	7905866	7905906	7905946	7905986	7014463
	200'-0"	7905867	7905907	7905947	7905987	7069089
	225'-0"	7905868	7905908	7905948	7905988	7014464
	250'-0"	7905869	7905909	7905949	7905989	7069090
	275'-0"	7905870	7905910	7905950	7905990	7069091
	300'-0"	7905871	7905911	7905951	7905991	7069092
	350'-0"	7905872	7905912	7905952	7905992	7014466
	400'-0"	7905873	7905913	7905953	7905993	7069093
	450'-0"	7905874	7905914	7905954	7905994	7069094
	500'-0"	7905875	7905915	7905955	7905995	7014467
	550'-0"	7905876	7905916	7905956	7905996	7069095
600'-0"	7905877	7905917	7905957	7905997	7069096	
SD2501 – Traction-Surface	25'-0"	7907060	7907100	7907140	7907180	7069100
	50'-0"	7907061	7907101	7907141	7907181	7061554
	75'-0"	7907062	7907102	7907142	7907182	7069101
	100'-0"	7907063	7907103	7907143	7907183	7009724
	125'-0"	7907064	7907104	7907144	7907184	7069102
	150'-0"	7907065	7907105	7907145	7907185	7014468
	175'-0"	7907066	7907106	7907146	7907186	7069103
	200'-0"	7907067	7907107	7907147	7907187	7069104
	225'-0"	7907068	7907108	7907148	7907188	7014469
	250'-0"	7907069	7907109	7907149	7907189	7069105
	275'-0"	7907070	7907110	7907150	7907190	7069106
	300'-0"	7907071	7907111	7907151	7907191	7069107
	350'-0"	7907072	7907112	7907152	7907192	7069108
	400'-0"	7907073	7907113	7907153	7907193	7069109
	450'-0"	7907074	7907114	7907154	7907194	7069110
	500'-0"	7907075	7907115	7907155	7907195	7069111
	550'-0"	7907076	7907116	7907156	7907196	7069112
600'-0"	7907077	7907117	7907157	7907197	7069113	

Table I - 17 Conveyor Style* / "A" Requirement

Style	"A"	Style**	"A"	Style**	"A"	STYLE**	"A"
1	88"	2	77"	3	96" / 186"	4	96" / 153"
		2J	105" / 144"	3A	96" / 130"	4A	96" / 105"
		2JA	105" / 96"	3B	136"	4B	125"
		2T	247.5"	3C	88"	4C	77"
		2TA	199.5"	3T	258.5"	4T	247.5"
				3TA	210.5"	4TA	199.5"

Refer to Section G for Style Identification

** For Styles 2J, 2JA, 3, 3A, 4, and 4A – "A" Dimension(s) = (Horizontal) / (Incline) Portions of Conveyor

Table I - 18 Additional Belt Length Requirements

Component	Adjust	"A"
For SA2001 Low Profile Intermediate Drive (instead of SA2000)	DEDUCT	3"
For SA2036 / 37 End Idler w/Knife-Edge Pulley	ADD	3"
For SA2038 End Idler w/ extended PTO shaft	ADD	2"
For SA2200 Automatic Spring-type Auxiliary Tale-UP	ADD	43"
For SA2220 Automatic Air-type Auxiliary Tale-UP	ADD	43"
For SA2301 Manual Screw-type Auxiliary Tale-UP	ADD	29"

Example:

Style 4 Belt Conveyor (28W) with:

- a. Straight Intermediate length in "horizontal" portion = 6'-0" (72"); 2X 72" = 144"
- b. Straight Intermediate length in "inclined" portion = 42'-0" (504"); 2X 504" = 1008"

Table I - 19

	Portion of Conveyor	
	Horizontal	Inclined
Top-Surface	Friction-Surface SD2500	Traction-Surface SD2501
Straight Intermediate Belt Length	144"	1008"
"A" Belt Length (per Table I-17)	96"	153"
Belt Length Requirement	240" = 20'	1061" = 88'-5"

Table I - 20 Cut to Length Belt CALLUP

BELT - _____	SD ____ – Length*
--------------	-------------------

(*) LENGTH = 2X Total Length of Intermediate Sections PLUS "A"

CALLUP = SD2500 – 20'; and SD 2501 - 88'-5"

Table I - 21 LACING - Part Numbers* and Quantity of Lacing Set(s) Required

			Belt Width		
Belting	Lacing	Lacing Card P/N*	12"	18" – 24"	30" - 36"
SD2500	Clipper #1	7506121	1 Set	2 Sets	3 Sets
SD2501	Clipper #1a	7109735			

(*) Part Numbers shown provide one (1) set of two (2) 12" lg. metal "lacings" (affixed to cardstock to keep them intact prior to field-attachment to belt). When ordering, specify the appropriate quantity of sets shown above for each belt splice.

It is recommended that extra(s) sets be ordered.

Table I - 22 LACING-PIN - Part Numbers and Length Ordering Requirements

			Belt Width				
Lacing	Lacing-Pin	P/N*	12"	18"	24"	30"	36"
Clipper #1	#25 Nylosteel	7125354	1'-0"	2'-0"	2'-0"	3'-0"	3'-0"
Clipper #1a							

(*) The standard unit of measure is 1'-0". When ordering, specify the appropriate length (shown above) for each belt splice.

Lacing-Pin "stock" is available in continuous lengths up to 100' (max.). When ordering a variety of lacing pins (quantity/length), consider ordering longer length(s) and cut to required length in field.

Table I - 23 Reducer Model / Ratio - Timing Belt Drives

Speed FPM	Reducer Brand	Power Unit Horsepower							
		.5	.75	1.0	1.5	2.0	3.0	5.0	7.5
FOR SA2000 INTERMEDIATE DRIVE POWER UNITS (TIMING BELT)									
30	Dodge	200 / 50	230 / 50	230 / 60	350 / 60	n.a	n.a	n.a	n.a
	Grove	224 / 50	230 / 50	242 / 60	242 / 60				
45	Dodge	200 / 40	230 / 40	260 / 40	300 / 40	n.a	n.a	n.a	n.a
	Grove	224 / 40	224 / 40	230 / 40	242 / 40				
60	Dodge	175 / 30	230 / 30	260 / 30	300/30	n.a.	n.a	n.a	n.a
	Grove	224 / 30	224 / 30	230 / 30	242 / 30	242 / 30			
75	Dodge	175 / 25	200 / 25	230 / 25	260 / 25	300 / 25	350 / 25	n.a	n.a
	Grove	224 / 25	224 / 25	224 / 25	232 / 25	242 / 25	242 / 25		
90	Dodge	175 / 20	175 / 20	200 / 20	230 / 20	260 / 20	300 / 20	n.a	n.a
	Grove	220 / 20	220 / 20	224 / 20	224 / 20	242 / 20	242 / 20		
105	Dodge	175 / 15	175 / 15	175 / 15	230 / 15	260 / 15	300 / 15	n.a.	n.a
	Grove	220 / 15	224 / 15	224 / 15	224 / 15	230 / 15	242 / 20	242 / 20	
120	Dodge	175 / 15	175 / 15	175 / 15	230 / 15	230 / 15	300 / 15	350 / 15	n.a
	Grove	220 / 15	220 / 15	220 / 15	226 / 15	232 / 15	242 / 15	242 / 15	
135	Dodge	175 / 15	175 / 15	175 / 15	230 / 15	230 / 15	300 / 15	350 / 15	n.a
	Grove	220 / 15	220 / 15	224 / 15	224 / 15	226 / 15	232 / 15	242 / 15	
150	Dodge	175 / 15	175 / 15	175 / 15	200 / 15	230 / 15	300 / 15	350 / 15	n.a
	Grove	220 / 10	220 / 10	220 / 10	224 / 10	224 / 10	232 / 15	242 / 15	
165	Dodge	175 / 15	175 / 15	175 / 15	200 / 15	230 / 15	300 / 15	350 / 15	n.a
	Grove	220 / 10	220 / 10	220 / 10	224 / 10	224 / 10	232 / 15	242 / 15	
180	Dodge	175 / 10	175 / 10	175 / 10	200 / 10	230 / 10	260 / 10	300 / 10	350 / 10
	Grove	220 / 10	220 / 10	220 / 10	226 / 10	226 / 10	230 / 10	242 / 15	242 / 15
200	Dodge	175 / 7*	175 / 7*	175 / 7*	175 / 7*	200 / 7*	230 / 7*	300 / 10	350 / 10
	Grove	220 / 7*	220 / 7*	220 / 7*	224 / 7*	224 / 7*	226 / 7*	242 / 10	242 / 10
225	Dodge	175 / 7*	175 / 7*	175 / 7*	175 / 7*	200 / 7*	230 / 7*	300 / 7*	350 / 10
	Grove	220 / 7*	220 / 7*	220 / 7*	224 / 7*	224 / 7*	226 / 7*	232 / 10	242 / 10
250	Dodge	175 / 7*	175 / 7*	175 / 7*	175 / 7*	200 / 7*	230 / 7*	300 / 7*	350 / 7*
	Grove	220 / 7*	220 / 7*	220 / 7*	220 / 7*	224 / 7*	226 / 7*	242 / 10	242 / 10
275	Dodge	175 / 5	175 / 5	175 / 5	175 / 5	175 / 5	230 / 5	300 / 7*	350 / 7*
	Grove	220 / 5	220 / 5	220 / 5	220 / 5	226 / 7*	226 / 7*	232 / 7*	242 / 7*
300	Dodge	175 / 5	175 / 5	175 / 5	175 / 5	175 / 5	230 / 5	300 / 7*	175 / 7*
	Grove	220 / 5	220 / 5	220 / 5	220 / 5	224 / 5	224 / 5	230 / 5	242 / 7*
325	Dodge	175 / 5	175 / 5	175 / 5	175 / 5	175 / 5	230 / 5	260 / 5	350 / 7*
	Grove	220 / 5	220 / 5	220 / 5	220 / 5	220 / 5	224 / 5	230 / 5	242 / 5
350	Dodge	175 / 5	175 / 5	175 / 5	175 / 5	175 / 5	230 / 5	260 / 5	350 / 7*
	Grove	220 / 5	220 / 5	220 / 5	220 / 5	220 / 5	224 / 5	230 / 5	242 / 7*
375	Dodge	175 / 5	175 / 5	175 / 5	175 / 5	175 / 5	260 / 5	260 / 5	350 / 7*
	Grove	220 / 5	220 / 5	220 / 5	220 / 5	220 / 5	224 / 5	230 / 5	242 / 7*
400	Dodge	175 / 5	175 / 5	175 / 5	175 / 5	175 / 5	260 / 5	260 / 5	350 / 5
	Grove	220 / 5	220 / 5	220 / 5	220 / 5	220 / 5	224 / 5	230 / 5	242 / 5
425	Dodge	175 / 5	175 / 5	175 / 5	175 / 5	175 / 5	260 / 5	260 / 5	350 / 5
	Grove	220 / 5	220 / 5	220 / 5	220 / 5	224 / 5	224 / 5	230 / 5	242 / 5
450	Dodge	175 / 5	175 / 5	175 / 5	175 / 5	175 / 5	260 / 5	260 / 5	350 / 5
	Grove	220 / 5	220 / 5	220 / 5	220 / 5	220 / 5	224 / 5	230 / 5	242 / 5
475	Dodge	175 / 5	175 / 5	175 / 5	175 / 5	175 / 5	260 / 5	260 / 5	350 / 5
	Grove	220 / 5	220 / 5	220 / 5	220 / 5	220 / 5	224 / 5	230 / 5	242 / 5
500	Dodge	175 / 5	175 / 5	175 / 5	175 / 5	175 / 5	260 / 5	260 / 5	350 / 5
	Grove	220 / 5	220 / 5	220 / 5	220 / 5	220 / 5	226 / 5	230 / 5	242 / 5

(*) Actual 7.5:1 Reducer Ratio. For Reducer Part Numbers see Table I-2 (Dodge) or Table I-3 (Grove)

Table I - 23 Reducer Model / Ratio - Time Belt Drive (continued)

Speed FPM	Reducer Brand	Power Unit Horsepower							
		.5	.75	1.0	1.5	2.0	3.0	5.0	7.5
FOR SA2001 LOW-PROFILE INTERMEDIATE DRIVE POWER UNITS (TIMING BELT)									
30	Dodge	200 / 50	230 / 50	300 / 60	n.a.	n.a.	n.a.	n.a.	n.a.
	Grove	224 / 50	230 / 50	230 / 60					
45	Dodge	200 / 40	230 / 40	260 / 40	350 / 50	n.a.	n.a.	n.a.	n.a.
	Grove	220 / 40	224 / 40	230 / 40	232 / 50	n.a.			
60	Dodge	200 / 25	200 / 25	230 / 25	260 / 25	n.a.	n.a.	n.a.	n.a.
	Grove	220 / 25	224 / 25	224 / 25	232 / 25	232 / 25			
75	Dodge	200 / 20	200 / 20	200 / 20	230 / 20	260 / 20	n.a.	n.a.	n.a.
	Grove	220 / 20	220 / 20	224 / 20	230 / 20	242 / 20			
90	Dodge	200 / 15	200 / 15	200 / 15	230 / 15	260 / 15	n.a.	n.a.	n.a.
	Grove	220 / 15	220 / 15	224 / 15	224 / 15	230 / 20	232 / 20		
105	Dodge	200 / 15	200 / 15	200 / 15	230 / 15	230 / 15	n.a.	n.a.	n.a.
	Grove	220 / 15	220 / 15	220 / 15	224 / 15	230 / 15	232 / 20		
120	Dodge	200 / 15	200 / 15	200 / 15	230 / 15	230 / 15	300 / 15	350 / 15	n.a.
	Grove	220 / 15	220 / 15	220 / 15	224 / 15	226 / 15	232 / 15	232 / 15	
135	Dodge	200 / 10	200 / 10	200 / 10	200 / 10	230 / 10	300 / 10	350 / 10	n.a.
	Grove	220 / 10	220 / 10	220 / 10	224 / 10	224 / 10	230 / 15	242 / 15	
150	Dodge	200 / 10	200 / 10	200 / 10	200 / 10	230 / 10	260 / 10	300 / 10	n.a.
	Grove	220 / 10	220 / 10	220 / 10	224 / 10	224 / 10	230 / 10	232 / 10	
165	Dodge	200 / 10	200 / 10	200 / 10	200 / 10	230 / 10	260 / 10	300 / 10	n.a.
	Grove	220 / 10	220 / 10	220 / 10	220 / 10	224 / 10	230 / 10	232 / 10	
180	Dodge	200 / 7*	200 / 7*	200 / 7*	200 / 7*	200 / 7*	230 / 7*	300 / 10	n.a.
	Grove	220 / 7*	220 / 7*	220 / 7*	220 / 7*	224 / 7*	226 / 7*	232 / 10	
200	Dodge	200 / 7*	200 / 7*	200 / 7*	200 / 7*	200 / 7*	230 / 7*	300 / 10	350 / 10
	Grove	220 / 7*	220 / 7*	220 / 7*	220 / 7*	224 / 7*	226 / 7*	232 / 7*	232 / 10
225	Dodge	200 / 7*	200 / 7*	200 / 7*	200 / 7*	200 / 7*	230 / 7*	300 / 10	350 / 10
	Grove	220 / 7*	220 / 7*	220 / 7*	220 / 7*	224 / 7*	226 / 7*	232 / 7*	232 / 10
250	Dodge	200 / 7*	200 / 7*	200 / 7*	200 / 7*	200 / 7*	230 / 7*	300 / 10	350 / 10
	Grove	220 / 7*	220 / 7*	220 / 7*	220 / 7*	224 / 7*	226 / 7*	232 / 7*	242 / 7*
275	Dodge	200 / 5	200 / 5	200 / 5	200 / 5	200 / 5	230 / 5	260 / 5	350 / 7*
	Grove	220 / 5	220 / 5	220 / 5	220 / 5	220 / 5	224 / 5	230 / 5	242 / 7*
300	Dodge	200 / 5	200 / 5	200 / 5	200 / 5	200 / 5	230 / 5	260 / 5	350 / 5
	Grove	220 / 5	220 / 5	220 / 5	220 / 5	220 / 5	224 / 5	230 / 5	242 / 7*
325	Dodge	200 / 5	200 / 5	200 / 5	200 / 5	200 / 5	230 / 5	260 / 5	350 / 5
	Grove	220 / 5	220 / 5	220 / 5	220 / 5	220 / 5	224 / 5	230 / 5	242 / 5
350	Dodge	200 / 5	200 / 5	200 / 5	200 / 5	200 / 5	230 / 5	260 / 5	350 / 5
	Grove	220 / 5	220 / 5	220 / 5	220 / 5	220 / 5	224 / 5	230 / 5	242 / 5
375	Dodge	200 / 5	200 / 5	200 / 5	200 / 5	200 / 5	230 / 5	260 / 5	350 / 5
	Grove	220 / 5	220 / 5	220 / 5	220 / 5	220 / 5	224 / 5	230 / 5	242 / 5
400	Dodge	200 / 5	200 / 5	200 / 5	200 / 5	200 / 5	230 / 5	260 / 5	350 / 5
	Grove	220 / 5	220 / 5	220 / 5	220 / 5	220 / 5	224 / 5	230 / 5	242 / 5
425	Dodge	200 / 5	200 / 5	200 / 5	200 / 5	200 / 5	230 / 5	260 / 5	350 / 5
	Grove	220 / 5	220 / 5	220 / 5	220 / 5	220 / 5	224 / 5	230 / 5	242 / 5
450	Dodge	200 / 5	200 / 5	200 / 5	200 / 5	200 / 5	230 / 5	260 / 5	350 / 5
	Grove	220 / 5	220 / 5	220 / 5	220 / 5	220 / 5	224 / 5	230 / 5	242 / 5
475	Dodge	200 / 5	200 / 5	200 / 5	200 / 5	200 / 5	230 / 5	260 / 5	350 / 5
	Grove	220 / 5	220 / 5	220 / 5	220 / 5	220 / 5	224 / 5	230 / 5	242 / 5
500	Dodge	200 / 5	200 / 5	200 / 5	200 / 5	200 / 5	230 / 5	260 / 5	350 / 5
	Grove	220 / 5	220 / 5	220 / 5	220 / 5	220 / 5	224 / 5	230 / 5	242 / 5

(*) Actual 7.5:1 Reducer Ratio. For Reducer Part Numbers see Table I-2 (Dodge) or Table I-3 (Grove)

Table I - 23 Reducer Model / Ratio - Time Belt Drive (continued)

Speed FPM	Reducer Brand	Power Unit Horsepower						
		.5	.75	1.0	1.5	2.0	3.0	5.0
FOR SA2030 / SA2031 / SA2032 END DRIVE (4" PULLEY) POWER UNITS (TIMING BELT)								
30	Dodge	200 / 40	n.a.	n.a.	n.a.	n.a.	n.a.	n.a.
	Grove	224 / 40						
45	Dodge	200 / 30	200 / 30	n.a.	n.a.	n.a.	n.a.	n.a.
	Grove	220 / 30						
60	Dodge	200 / 20	200 / 20	200 / 20	n.a.	n.a.	n.a.	n.a.
	Grove	220 / 20						
75	Dodge	200 / 20	200 / 20	200 / 20	230 / 20	n.a.	n.a.	n.a.
	Grove	220 / 20						
90	Dodge	200 / 15	200 / 15	200 / 15	230 / 15	n.a.	n.a.	n.a.
	Grove	220 / 15						
105	Dodge	200 / 15	200 / 15	200 / 15	230 / 15	n.a.	n.a.	n.a.
	Grove	220 / 15						
120	Dodge	200 / 10	200 / 10	200 / 10	200 / 10	230 / 10	n.a.	n.a.
	Grove	220 / 10						
135	Dodge	200 / 10	200 / 10	200 / 10	200 / 10	230 / 10	n.a.	n.a.
	Grove	220 / 10						
150	Dodge	200 / 10	200 / 10	200 / 10	200 / 10	230 / 10	n.a.	n.a.
	Grove	220 / 10						
165	Dodge	200 / 10	200 / 10	200 / 10	200 / 10	230 / 10	260 / 10	n.a.
	Grove	220 / 10						
180	Dodge	200 / 7*	200 / 7*	200 / 7*	200 / 7*	200 / 7*	230 / 7*	n.a.
	Grove	220 / 7*						
200	Dodge	200 / 7*	200 / 7*	200 / 7*	200 / 7*	200 / 7*	230 / 7*	n.a.
	Grove	220 / 7*						
225	Dodge	200 / 7*	200 / 7*	200 / 7*	200 / 7*	200 / 7*	230 / 7*	n.a.
	Grove	220 / 7*						
250	Dodge	200 / 5	200 / 5	200 / 5	200 / 5	200 / 5	200 / 5	n.a.
	Grove	220 / 5						
275	Dodge	200 / 5	200 / 5	200 / 5	200 / 5	200 / 5	230 / 5	260 / 5
	Grove	220 / 5						
300	Dodge	200 / 5	200 / 5	200 / 5	200 / 5	200 / 5	230 / 5	260 / 5
	Grove	220 / 5						
325	Dodge	200 / 5	200 / 5	200 / 5	200 / 5	200 / 5	230 / 5	260 / 5
	Grove	220 / 5						
350	Dodge	200 / 5	200 / 5	200 / 5	200 / 5	200 / 5	230 / 5	260 / 5
	Grove	220 / 5						
375	Dodge	200 / 5	200 / 5	200 / 5	200 / 5	200 / 5	230 / 5	n.a.
	Grove	220 / 5						
400	Dodge	200 / 5	200 / 5	200 / 5	200 / 5	200 / 5	230 / 5	260 / 5
	Grove	220 / 5						
425	Dodge	200 / 5	200 / 5	200 / 5	200 / 5	200 / 5	230 / 5	260 / 5
	Grove	220 / 5						
450	Dodge	200 / 5	200 / 5	200 / 5	200 / 5	200 / 5	230 / 5	260 / 5
	Grove	220 / 5						
475	Dodge	200 / 5	200 / 5	200 / 5	200 / 5	200 / 5	230 / 5	260 / 5
	Grove	220 / 5						
500	Dodge	200 / 5	200 / 5	200 / 5	200 / 5	200 / 5	230 / 5	260 / 5
	Grove	220 / 5						

(*) Actual 7.5:1 Ratio. For Reducer Part Numbers see Table I-2 (Dodge) or Table I-3 (Grove)

Table I - 24 Reducer Model / Ratio - Chain Drives

Conveyor Speed	Reducer Brand	Power Unit Horsepower					
		.5	.75	1.0	1.5	2.0	3.0
FOR SA2000 INTERMEDIATE DRIVE POWER UNITS (CHAIN-DRIVE)							
30 FPM	Dodge	230 / 60	260 / 60	300 / 60	350 / 60	n.a.	n.a.
	Grove	224 / 60	230 / 60	230 / 60	232 / 60		
45 FPM	Dodge	230 / 60	260 / 60	300 / 60	350 / 50	n.a.	n.a.
	Grove	224 / 60	230 / 60	230 / 60	232 / 60		
60 FPM	Dodge	200 / 40	230 / 40	260 / 40	300 / 40	300 / 30	350 / 30
	Grove	220 / 40	224 / 40	226 / 40	232 / 40	242 / 40	242 / 40
75 FPM	Dodge	200 / 40	230 / 40	260 / 40	300 / 40	300 / 40	350 / 40
	Grove	220 / 40	224 / 40	226 / 40	232 / 40	242 / 40	242 / 40
90 FPM	Dodge	175 / 25	200 / 25	230 / 25	260 / 25	300 / 25	350 / 25
	Grove	220 / 30	224 / 30	224 / 30	230 / 30	232 / 30	242 / 30
105 FPM	Dodge	175 / 25	200 / 25	230 / 25	260 / 25	300 / 25	300 / 20
	Grove	220 / 25	220 / 25	224 / 25	226 / 25	230 / 25	242 / 25
120 FPM	Dodge	175 / 20	175 / 20	200 / 20	230 / 20	260 / 20	300 / 20
	Grove	220 / 20	220 / 20	220 / 20	224 / 20	230 / 20	232 / 20
135 FPM	Dodge	175 / 20	175 / 20	200 / 20	230 / 20	260 / 20	300 / 20
	Grove	220 / 20	220 / 20	220 / 20	224 / 20	230 / 20	232 / 20
150 FPM	Dodge	175 / 15	175 / 15	175 / 15	230 / 15	230 / 15	300 / 15
	Grove	220 / 15	220 / 15	220 / 15	224 / 15	226 / 15	230 / 15
165 FPM	Dodge	175 / 15	175 / 15	175 / 15	230 / 15	230 / 15	300 / 15
	Grove	220 / 15	220 / 15	220 / 15	224 / 15	226 / 15	230 / 15
180 FPM	Dodge	175 / 15	175 / 15	175 / 15	230 / 15	230 / 15	300 / 15
	Grove	220 / 15	220 / 15	220 / 15	224 / 15	226 / 15	230 / 15
FOR SA2001 Low-Profile INTERMEDIATE DRIVE POWER UNITS (CHAIN DRIVE)							
30 FPM	Dodge	200 / 50	230 / 50	260 / 50	n.a.	n.a.	n.a.
	Grove	224 / 50	226 / 50	230 / 50			
45 FPM	Dodge	200 / 40	230 / 40	260 / 40	300 / 40	n.a.	n.a.
	Grove	220 / 40	224 / 40	226 / 40	232 / 40		
60 FPM	Dodge	200 / 30	200 / 30	230 / 30	260 / 30	300 / 30	n.a.
	Grove	220 / 40	224 / 40	226 / 40	232 / 40	242 / 40	
75 FPM	Dodge	200 / 25	200 / 25	230 / 25	260 / 25	300 / 25	350 / 25
	Grove	220 / 30	224 / 30	224 / 30	230 / 30	232 / 30	242 / 30
90 FPM	Dodge	200 / 20	200 / 20	200 / 20	230 / 20	260 / 20	300 / 20
	Grove	220 / 25	220 / 25	224 / 25	226 / 25	230 / 25	242 / 25
105 FPM	Dodge	200 / 15	200 / 15	200 / 15	230 / 15	230 / 15	300 / 15
	Grove	220 / 15	220 / 15	220 / 15	224 / 15	226 / 15	230 / 15
120 FPM	Dodge	200 / 15	200 / 15	200 / 15	230 / 15	230 / 15	300 / 15
	Grove	220 / 15	220 / 15	220 / 15	224 / 15	226 / 15	230 / 15
135 FPM	Dodge	200 / 15	200 / 15	200 / 15	230 / 15	230 / 15	300 / 15
	Grove	220 / 15	220 / 15	220 / 15	224 / 15	226 / 15	230 / 15
150 FPM	Dodge	200 / 15	200 / 15	200 / 15	230 / 15	230 / 15	300 / 15
	Grove	220 / 15	220 / 15	220 / 15	224 / 15	226 / 15	230 / 15
165 FPM	Dodge	200 / 15	200 / 15	200 / 15	230 / 15	230 / 15	300 / 15
	Grove	220 / 15	220 / 15	220 / 15	224 / 15	226 / 15	230 / 15
180 FPM	Dodge	200 / 10	200 / 10	200 / 10	200 / 10	230 / 10	260 / 10
	Grove	220 / 10	220 / 10	220 / 10	224 / 10	226 / 10	230 / 10

(*) Actual 7.5:1 Reducer Ratio

For Part Numbers see Tables I-2 (Dodge) or Table I-3 (Grove)

Table I - 24 Reducer Model / Ratio - Chain Drives (continued)

Conveyor Speed	Reducer Brand	Power Unit Horsepower					
		.5	.75	1.0	1.5	2.0	3.0
FOR SA2030/31/32 END DRIVE (4" Dia. Pulley) POWER UNITS (CHAIN-DRIVE)							
30 FPM	Dodge	220 / 50	230 / 50	n.a.	n.a.	n.a.	n.a.
	Grove	224 / 50	n.a.				
45 FPM	Dodge	220 / 40	230 / 40	n.a.	n.a.	n.a.	n.a.
	Grove	220 / 40	224 / 40				
60 FPM	Dodge	200 / 30	200 / 30	230 / 30	n.a.	n.a.	n.a.
	Grove	220 / 30	224 / 30				
75 FPM	Dodge	200 / 25	200 / 25	230 / 25	260 / 25	n.a.	n.a.
	Grove	220 / 25	220 / 25	224 / 25	226 / 25		
90 FPM	Dodge	200 / 20	200 / 20	200 / 20	230 / 20	n.a.	n.a.
	Grove	220 / 20	220 / 20	220 / 20	224 / 20		
105 FPM	Dodge	200 / 20	200 / 20	200 / 20	230 / 20	n.a.	n.a.
	Grove	220 / 20	220 / 20	220 / 20	224 / 20		
120 FPM	Dodge	200 / 15	200 / 15	200 / 15	230 / 15	230 / 15	n.a.
	Grove	220 / 15	220 / 15	220 / 15	224 / 15	226 / 15	
135 FPM	Dodge	200 / 15	200 / 15	200 / 15	230 / 15	230 / 15	n.a.
	Grove	220 / 15	220 / 15	220 / 15	224 / 15	226 / 15	
150 FPM	Dodge	200 / 10	200 / 10	200 / 10	200 / 10	230 / 10	n.a.
	Grove	220 / 10	220 / 10	220 / 10	220 / 10	224 / 10	
165 FPM	Dodge	200 / 10	200 / 10	200 / 10	200 / 10	230 / 10	260 / 10
	Grove	220 / 10	220 / 10	220 / 10	220 / 10	224 / 10	226 / 10
180 FPM	Dodge	200 / 10	200 / 10	200 / 10	200 / 10	230 / 10	230 / 10
	Grove	220 / 10	220 / 10	220 / 10	220 / 10	224 / 10	226 / 10

(*) Actual 7.5:1 Reducer Ratio

For Part Numbers see Tables I-2 (Dodge) or Table I-3 (Grove)

Table I - 25 Number of TEETH - DRIVER / DRIVEN SPROCKETS

Speed FPM	Reducer Brand	Power Unit Horsepower							
		.5	.75	1.0	1.5	2.0	3.0	5.0	7.5
FOR SA2000 INTERMEDIATE DRIVE POWER UNITS (TIMING BELT)									
30	Dodge	32 / 80	32 / 80	28 / 56	28 / 56	n.a.	n.a.	n.a.	n.a.
	Grove	32 / 80	32 / 80	28 / 56	28 / 56				
45	Dodge	38 / 80	38 / 80	38 / 80	28 / 56	n.a.	n.a.	n.a.	n.a.
	Grove	40 / 80	40 / 80	40 / 80	28 / 56				
60	Dodge	38 / 80	38 / 80	38 / 80	38 / 80	28 / 56	n.a.	n.a.	n.a.
	Grove	40 / 80	40 / 80	80 / 80	28 / 56	28 / 56			
75	Dodge	40 / 80	40 / 80	40 / 80	40 / 80	40 / 80	40 / 80	n.a.	n.a.
	Grove	40 / 80	40 / 80	40 / 80	40 / 80	28 / 56	28 / 56		
90	Dodge	38 / 80	38 / 80	38 / 80	38 / 80	28 / 56	28 / 56	n.a.	n.a.
	Grove	38 / 80	38 / 80	38 / 80	38 / 80	28 / 56	28 / 56		
105	Dodge	34 / 80	34 / 80	34 / 80	34 / 80	34 / 80	34 / 80	n.a.	n.a.
	Grove	34 / 80	34 / 80	34 / 80	34 / 80	34 / 80	31 / 56		
120	Dodge	38 / 80	38 / 80	38 / 80	38 / 80	38 / 80	36 / 56	28 / 56	n.a.
	Grove	38 / 80	38 / 80	38 / 80	38 / 80	38 / 80	28 / 56	28 / 56	
135	Dodge	42 / 80	42 / 80	42 / 80	42 / 80	42 / 80	30 / 56	30 / 56	n.a.
	Grove	42 / 80	42 / 80	42 / 80	42 / 80	42 / 80	30 / 56	30 / 56	
150	Dodge	32 / 80	32 / 80	32 / 80	32 / 80	32 / 80	33 / 56	33 / 56	n.a.
	Grove	32 / 80	32 / 80	32 / 80	32 / 80	32 / 80	34 / 56	32 / 56	
165	Dodge	36 / 80	36 / 80	36 / 80	36 / 80	36 / 80	37 / 56	37 / 56	n.a.
	Grove	36 / 80	36 / 80	36 / 80	36 / 80	36 / 80	35 / 53	35 / 53	
180	Dodge	38 / 80	38 / 80	38 / 80	38 / 80	38 / 80	38 / 80	28 / 56	28 / 56
	Grove	38 / 80	38 / 80	38 / 80	38 / 80	38 / 80	38 / 80	36 / 50	36 / 50
200	Dodge	32 / 80	32 / 80	32 / 80	32 / 80	32 / 80	32 / 80	30 / 56	30 / 56
	Grove	32 / 80	32 / 80	32 / 80	32 / 80	32 / 80	32 / 80	30 / 56	30 / 56
225	Dodge	36 / 80	36 / 80	36 / 80	36 / 80	36 / 80	36 / 80	36 / 80	33 / 56
	Grove	36 / 80	36 / 80	36 / 80	36 / 80	36 / 80	36 / 80	34 / 56	32 / 53
250	Dodge	36 / 71	36 / 71	36 / 71	36 / 71	36 / 71	36 / 71	28 / 56	28 / 56
	Grove	38 / 80	38 / 80	38 / 80	38 / 80	40 / 80	40 / 80	35 / 53	35 / 53
275	Dodge	30 / 80	30 / 80	30 / 80	30 / 80	30 / 80	30 / 80	31 / 56	31 / 56
	Grove	30 / 80	30 / 80	30 / 80	30 / 80	38 / 71	38 / 71	31 / 56	31 / 56
300	Dodge	32 / 80	32 / 80	32 / 80	32 / 80	32 / 80	32 / 80	33 / 56	33 / 56
	Grove	32 / 80	32 / 80	32 / 80	32 / 80	32 / 80	32 / 80	32 / 80	32 / 53
325	Dodge	34 / 80	34 / 80	34 / 80	34 / 80	34 / 80	34 / 80	32 / 75	34 / 53
	Grove	36 / 80	34 / 80	34 / 80	34 / 80	34 / 80	34 / 80	34 / 80	34 / 53
350	Dodge	38 / 80	38 / 80	38 / 80	38 / 80	38 / 80	38 / 80	38 / 80	37 / 53
	Grove	38 / 80	38 / 80	38 / 80	38 / 80	38 / 80	38 / 80	38 / 80	37 / 53
375	Dodge	38 / 75	38 / 75	38 / 75	38 / 75	38 / 75	38 / 75	38 / 75	37 / 50
	Grove	38 / 75	40 / 80	40 / 80	40 / 80	40 / 80	40 / 80	40 / 80	37 / 50
400	Dodge	42 / 80	42 / 80	42 / 80	42 / 80	42 / 80	42 / 80	42 / 80	37 / 56
	Grove	42 / 80	42 / 80	42 / 80	42 / 80	42 / 80	42 / 80	42 / 80	30 / 56
425	Dodge	45 / 80	45 / 80	45 / 80	45 / 80	45 / 80	45 / 80	45 / 80	30 / 53
	Grove	45 / 80	45 / 80	45 / 80	45 / 80	45 / 80	45 / 80	45 / 80	32 / 56
450	Dodge	48 / 80	48 / 80	48 / 80	48 / 80	48 / 80	48 / 80	48 / 80	32 / 53
	Grove	48 / 80	48 / 80	48 / 80	48 / 80	48 / 80	48 / 80	48 / 80	32 / 53
475	Dodge	50 / 80	50 / 80	50 / 80	50 / 80	50 / 80	50 / 80	50 / 80	33 / 53
	Grove	50 / 80	50 / 80	50 / 80	50 / 80	50 / 80	50 / 80	50 / 80	33 / 53
500	Dodge	48 / 71	48 / 71	48 / 71	48 / 71	48 / 71	48 / 71	48 / 71	35 / 53
	Grove	48 / 71	48 / 71	48 / 71	48 / 71	48 / 71	48 / 71	48 / 71	35 / 53

For Part Numbers, see Tables I-6 (for Driver Sprockets) and Table I-8 (for Driven Sprockets)

Table I - 25 Number of TEETH - DRIVER / DRIVEN SPROCKETS (continued)

Speed FPM	Reducer Brand	Power Unit Horsepower							
		.5	.75	1.0	1.5	2.0	3.0	5.0	7.5
FOR SA2001 Low Profile INTERMEDIATE DRIVE POWER UNITS (TIMING BELT)									
30	Dodge	36 / 63	36 / 63	33 / 48	n.a.	n.a.	n.a.	n.a.	n.a.
	Grove	36 / 63	36 / 63	33 / 48					
45	Dodge	42 / 63	42 / 63	42 / 63	40 / 48	n.a.	n.a.	n.a.	n.a.
	Grove	42 / 63	42 / 63	42 / 63	40 / 48				
60	Dodge	36 / 63	36 / 63	36 / 63	36 / 63	n.a.	n.a.	n.a.	n.a.
	Grove	36 / 63	36 / 63	36 / 63	36 / 63	34 / 48			
75	Dodge	36 / 63	36 / 63	36 / 63	36 / 63	36 / 63	n.a.	n.a.	n.a.
	Grove	36 / 63	36 / 63	36 / 63	36 / 63	36 / 63	34 / 48		
90	Dodge	32 / 63	32 / 63	32 / 63	32 / 63	42 / 60	n.a.	n.a.	n.a.
	Grove	32 / 63	32 / 63	32 / 63	32 / 63	42 / 60	33 / 48		
105	Dodge	38 / 63	38 / 63	38 / 63	38 / 63	38 / 63	n.a.	n.a.	n.a.
	Grove	38 / 63	38 / 63	38 / 63	38 / 63	38 / 63	38 / 48		
120	Dodge	42 / 63	42 / 63	42 / 63	42 / 63	42 / 63	42 / 63	33 / 48	n.a.
	Grove	42 / 63	42 / 63	42 / 63	42 / 63	42 / 63	42 / 63	33 / 48	
135	Dodge	32 / 63	32 / 63	32 / 63	32 / 63	32 / 63	42 / 56	37 / 48	n.a.
	Grove	32 / 63	32 / 63	32 / 63	32 / 63	32 / 63	42 / 56	37 / 48	
150	Dodge	36 / 63	36 / 63	36 / 63	36 / 63	36 / 63	36 / 63	28 / 48	n.a.
	Grove	36 / 63	36 / 63	36 / 63	36 / 63	36 / 63	36 / 63	28 / 48	
165	Dodge	40 / 63	40 / 63	40 / 63	40 / 63	40 / 63	40 / 63	30 / 48	n.a.
	Grove	40 / 63	40 / 63	40 / 63	40 / 63	40 / 63	40 / 63	30 / 48	
180	Dodge	32 / 63	32 / 63	32 / 63	32 / 63	32 / 63	32 / 63	33 / 48	n.a.
	Grove	32 / 63	32 / 63	32 / 63	32 / 63	32 / 63	32 / 63	33 / 48	
200	Dodge	36 / 63	36 / 63	36 / 63	36 / 63	36 / 63	36 / 63	36 / 48	36 / 48
	Grove	36 / 63	36 / 63	36 / 63	36 / 63	36 / 63	36 / 63	36 / 63	36 / 48
225	Dodge	40 / 63	40 / 63	40 / 63	40 / 63	40 / 63	40 / 63	40 / 48	40 / 48
	Grove	40 / 63	40 / 63	40 / 63	40 / 63	40 / 63	40 / 63	40 / 63	40 / 48
250	Dodge	45 / 63	45 / 63	45 / 63	45 / 63	45 / 63	45 / 63	45 / 48	45 / 48
	Grove	45 / 63	45 / 63	45 / 63	45 / 63	45 / 63	45 / 63	42 / 60	34 / 48
275	Dodge	34 / 63	34 / 63	34 / 63	34 / 63	34 / 63	34 / 63	34 / 63	37 / 48
	Grove	34 / 63	34 / 63	34 / 63	34 / 63	34 / 63	34 / 63	34 / 63	37 / 48
300	Dodge	36 / 63	36 / 63	36 / 63	36 / 63	36 / 63	36 / 63	36 / 63	28 / 48
	Grove	36 / 63	36 / 63	36 / 63	36 / 63	36 / 63	36 / 63	36 / 63	38 / 45
325	Dodge	38 / 63	38 / 63	38 / 63	38 / 63	38 / 63	38 / 63	38 / 63	29 / 48
	Grove	38 / 63	38 / 63	38 / 63	38 / 63	38 / 63	38 / 63	38 / 63	30 / 48
350	Dodge	42 / 63	42 / 63	42 / 63	42 / 63	42 / 63	42 / 63	42 / 63	32 / 48
	Grove	42 / 63	42 / 63	42 / 63	42 / 63	42 / 63	42 / 63	42 / 63	42 / 63
375	Dodge	45 / 63	45 / 63	45 / 63	45 / 63	45 / 63	45 / 63	42 / 60	34 / 48
	Grove	45 / 63	45 / 63	45 / 63	45 / 63	45 / 63	45 / 63	42 / 60	42 / 60
400	Dodge	45 / 60	45 / 60	45 / 60	45 / 60	45 / 60	45 / 60	45 / 60	36 / 48
	Grove	45 / 60	45 / 60	45 / 60	45 / 60	45 / 60	45 / 60	45 / 60	45 / 60
425	Dodge	48 / 56	48 / 56	48 / 56	48 / 56	48 / 56	48 / 56	48 / 56	39 / 48
	Grove	48 / 56	48 / 56	48 / 56	48 / 56	48 / 56	48 / 56	48 / 56	48 / 56
450	Dodge	48 / 56	48 / 56	48 / 56	48 / 56	48 / 56	48 / 56	48 / 56	40 / 48
	Grove	48 / 56	48 / 56	48 / 56	48 / 56	48 / 56	48 / 56	48 / 56	48 / 56
475	Dodge	45 / 50	45 / 50	45 / 50	45 / 50	45 / 50	45 / 50	45 / 50	43 / 48
	Grove	45 / 50	45 / 50	45 / 50	45 / 50	45 / 50	45 / 50	45 / 50	45 / 50
500	Dodge	38 / 40	38 / 40	38 / 40	38 / 40	38 / 40	38 / 40	38 / 40	45 / 48
	Grove	38 / 40	38 / 40	38 / 40	38 / 40	38 / 40	38 / 40	38 / 40	38 / 40

For Part Numbers, see Tables I-6 (for Driver Sprockets) or Table I-8 (for Driven Sprockets)

Table I - 25 Number of TEETH - DRIVER / DRIVEN SPROCKETS

Speed FPM	Reducer Brand	Power Unit Horsepower						
		.5	.75	1.0	1.5	2.0	3.0	5.0
FOR SA2030/31/32 END DRIVE POWER UNITS (TIMING BELT)								
30	Dodge	32 / 48	n.a.	n.a.	n.a.	n.a.	n.a.	n.a.
	Grove	32 / 48						
45	Dodge	32 / 42	32 / 42	n.a.	n.a.	n.a.	n.a.	n.a.
	Grove	34 / 45						
60	Dodge	30 / 45	30 / 45	30 / 45	n.a.	n.a.	n.a.	n.a.
	Grove	32 / 48	32 / 48					
75	Dodge	32 / 38	32 / 38	32 / 38	30 / 36	n.a.	n.a.	n.a.
	Grove	32 / 38	32 / 38	32 / 38	32 / 38			
90	Dodge	32 / 42	32 / 42	32 / 42	34 / 45	n.a.	n.a.	n.a.
	Grove	34 / 45	34 / 45	34 / 45	34 / 45			
105	Dodge	40 / 45	40 / 45	40 / 45	40 / 45	n.a.	n.a.	n.a.
	Grove	42 / 48	42 / 48	42 / 48	42 / 48			
120	Dodge	30 / 45	30 / 45	30 / 45	30 / 45	30 / 45	n.a.	n.a.
	Grove	32 / 48	32 / 48	32 / 48	32 / 48	32 / 48		
135	Dodge	32 / 42	32 / 42	32 / 42	32 / 42	34 / 45	n.a.	n.a.
	Grove	36 / 48	36 / 48	36 / 48	36 / 48	36 / 48		
150	Dodge	32 / 38	32 / 38	32 / 38	32 / 38	32 / 38	n.a.	n.a.
	Grove	32 / 38	32 / 38	32 / 38	32 / 38	32 / 38		
165	Dodge	36 / 40	36 / 40	36 / 40	36 / 40	36 / 40	36 / 40	n.a.
	Grove	34 / 38	34 / 38	34 / 38	34 / 38	34 / 38	34 / 38	
180	Dodge	32 / 42	32 / 42	32 / 42	32 / 42	32 / 42	32 / 42	n.a.
	Grove	34 / 45	34 / 45	34 / 45	34 / 45	34 / 45	34 / 45	
200	Dodge	38 / 45	38 / 45	38 / 45	38 / 45	38 / 45	38 / 45	n.a.
	Grove	40 / 48	40 / 48	40 / 48	40 / 48	40 / 48	40 / 48	
225	Dodge	42 / 45	42 / 45	42 / 45	42 / 45	42 / 45	42 / 45	n.a.
	Grove	42 / 45	42 / 45	42 / 45	42 / 45	42 / 45	42 / 45	
250	Dodge	34 / 48	34 / 48	34 / 48	34 / 48	34 / 48	34 / 48	34 / 48
	Grove	34 / 48	34 / 48	34 / 48	34 / 48	34 / 48	34 / 48	34 / 48
275	Dodge	32 / 42	32 / 42	32 / 42	32 / 42	32 / 42	34 / 45	34 / 45
	Grove	34 / 45	34 / 45	34 / 45	34 / 45	34 / 45	34 / 45	34 / 45
300	Dodge	34 / 40	34 / 40	34 / 40	34 / 40	34 / 40	36 / 42	36 / 42
	Grove	40 / 48	40 / 48	40 / 48	40 / 48	40 / 48	40 / 48	38 / 45
325	Dodge	36 / 40	36 / 40	36 / 40	36 / 40	36 / 40	36 / 40	38 / 42
	Grove	38 / 42	38 / 42	38 / 42	38 / 42	38 / 42	38 / 42	38 / 42
350	Dodge	38 / 38	38 / 38	38 / 38	38 / 38	38 / 38	40 / 40	40 / 40
	Grove	38 / 38	38 / 38	38 / 38	38 / 38	38 / 38	38 / 38	40 / 40
375	Dodge	40 / 38	40 / 38	40 / 38	40 / 38	40 / 38	42 / 40	n.a.
	Grove	42 / 40	42 / 40	42 / 40	42 / 40	42 / 40	42 / 40	42 / 40
400	Dodge	45 / 40	45 / 40	45 / 40	45 / 40	45 / 40	45 / 40	45 / 40
	Grove	42 / 38	42 / 38	42 / 38	42 / 38	42 / 38	42 / 38	42 / 38
425	Dodge	45 / 38	45 / 38	45 / 38	45 / 38	45 / 38	45 / 38	45 / 38
	Grove	45 / 38	45 / 38	45 / 38	45 / 38	45 / 38	45 / 38	45 / 38
450	Dodge	45 / 36	45 / 36	45 / 36	45 / 36	45 / 36	45 / 36	45 / 36
	Grove	45 / 36	45 / 36	45 / 36	45 / 36	45 / 36	45 / 36	45 / 36
475	Dodge	48 / 36	48 / 36	48 / 36	48 / 36	48 / 36	48 / 36	48 / 36
	Grove	50 / 38	50 / 38	50 / 38	50 / 38	50 / 38	50 / 38	45 / 34
500	Dodge	48 / 34	48 / 34	48 / 34	48 / 34	48 / 34	48 / 34	48 / 34
	Grove	50 / 36	50 / 36	50 / 36	50 / 36	50 / 36	50 / 36	50 / 36

For Part Numbers, see Tables I-6 (for Driver Sprockets) or Table I-8 (for Driven Sprockets)

Table I - 26 Number of TEETH - DRIVER / DRIVEN SPROCKETS

Conveyor Speed	Reducer Brand	Power Unit Horsepower					
		.5	.75	1.0	1.5	2.0	3.0
FOR SA2000 INTERMEDIATE DRIVE POWER UNITS (CHAIN DRIVE)							
30 FPM	Dodge	16 / 32	16 / 32	16 / 32	16 / 32	n.a.	n.a.
	Grove	16 / 32	16 / 32	16 / 32	16 / 32		
45 FPM	Dodge	23 / 32	23 / 32	23 / 32	19 / 32	n.a.	n.a.
	Grove	23 / 32	23 / 32	23 / 32	23 / 32		
60 FPM	Dodge	20 / 32	20 / 32	20 / 32	20 / 32	16 / 32	16 / 32
	Grove	21 / 32	21 / 32	21 / 32	21 / 32	21 / 32	21 / 32
75 FPM	Dodge	25 / 32	25 / 32	25 / 32	25 / 32	19 / 32	19 / 32
	Grove	25 / 32	25 / 32	25 / 32	25 / 32	25 / 32	25 / 32
90 FPM	Dodge	19 / 32	19 / 32	19 / 32	19 / 32	19 / 32	19 / 32
	Grove	23 / 32	23 / 32	23 / 32	23 / 32	23 / 32	23 / 32
105 FPM	Dodge	22 / 32	22 / 32	22 / 32	22 / 32	22 / 32	18 / 32
	Grove	22 / 32	22 / 32	22 / 32	22 / 32	22 / 32	22 / 32
120 FPM	Dodge	20 / 32	20 / 32	20 / 32	20 / 32	20 / 32	20 / 32
	Grove	20 / 32	20 / 32	20 / 32	20 / 32	20 / 32	20 / 32
135 FPM	Dodge	23 / 32	23 / 32	23 / 32	23 / 32	23 / 32	23 / 32
	Grove	23 / 32	23 / 32	23 / 32	23 / 32	23 / 32	23 / 32
150 FPM	Dodge	19 / 32	19 / 32	19 / 32	19 / 32	19 / 32	19 / 32
	Grove	19 / 32	19 / 32	19 / 32	19 / 32	19 / 32	19 / 32
165 FPM	Dodge	21 / 32	21 / 32	21 / 32	21 / 32	21 / 32	21 / 32
	Grove	21 / 32	21 / 32	21 / 32	21 / 32	21 / 32	21 / 32
180 FPM	Dodge	23 / 32	23 / 32	23 / 32	23 / 32	23 / 32	23 / 32
	Grove	23 / 32	23 / 32	23 / 32	23 / 32	23 / 32	23 / 32
FOR SA2001 Low-Profile INTERMEDIATE DRIVE POWER UNITS (CHAIN DRIVE)							
30 FPM	Dodge	38 / 40	38 / 40	38 / 40	38 / 40	38 / 40	38 / 40
	Grove	38 / 40	38 / 40	38 / 40			
45 FPM	Dodge	38 / 40	38 / 40	38 / 40	38 / 40	38 / 40	38 / 40
	Grove	38 / 40	38 / 40	38 / 40			
60 FPM	Dodge	38 / 40	38 / 40	38 / 40	38 / 40	38 / 40	38 / 40
	Grove	38 / 40	38 / 40	38 / 40	38 / 40	38 / 40	38 / 40
75 FPM	Dodge	38 / 40	38 / 40	38 / 40	38 / 40	38 / 40	38 / 40
	Grove	38 / 40	38 / 40	38 / 40	38 / 40	38 / 40	38 / 40
90 FPM	Dodge	38 / 40	38 / 40	38 / 40	38 / 40	38 / 40	38 / 40
	Grove	38 / 40	38 / 40	38 / 40	38 / 40	38 / 40	38 / 40
105 FPM	Dodge	38 / 40	38 / 40	38 / 40	38 / 40	38 / 40	38 / 40
	Grove	38 / 40	38 / 40	38 / 40	38 / 40	38 / 40	38 / 40
120 FPM	Dodge	38 / 40	38 / 40	38 / 40	38 / 40	38 / 40	38 / 40
	Grove	38 / 40	38 / 40	38 / 40	38 / 40	38 / 40	38 / 40
135 FPM	Dodge	38 / 40	38 / 40	38 / 40	38 / 40	38 / 40	38 / 40
	Grove	38 / 40	38 / 40	38 / 40	38 / 40	38 / 40	38 / 40
150 FPM	Dodge	38 / 40	38 / 40	38 / 40	38 / 40	38 / 40	38 / 40
	Grove	38 / 40	38 / 40	38 / 40	38 / 40	38 / 40	38 / 40
165 FPM	Dodge	38 / 40	38 / 40	38 / 40	38 / 40	38 / 40	38 / 40
	Grove	38 / 40	38 / 40	38 / 40	38 / 40	38 / 40	38 / 40
180 FPM	Dodge	38 / 40	38 / 40	38 / 40	38 / 40	38 / 40	38 / 40
	Grove	38 / 40	38 / 40	38 / 40	38 / 40	38 / 40	38 / 40

For Part Numbers see Tables I-6 (for Driver Sprocket) or Table I-8 (for Driven Sprocket)

Table I - 26 Number of TEETH - DRIVER / DRIVEN SPROCKETS (continued)

Conveyor Speed	Reducer Brand	Power Unit Horsepower					
		.5	.75	1.0	1.5	2.0	3.0
FOR SA2030/31/32 END DRIVE (4" Dia. Pulley) POWER UNITS (CHAIN-DRIVE)							
30 FPM	Dodge	16 / 19	16 / 19	n.a.	n.a.	n.a.	n.a.
	Grove	16 / 19	n.a.				
45 FPM	Dodge	19 / 19	19 / 19	n.a.	n.a.	n.a.	n.a.
	Grove	19 / 19	19 / 19				
60 FPM	Dodge	19 / 19	19 / 19	19 / 19	n.a.	n.a.	n.a.
	Grove	19 / 19	19 / 19	19 / 19			
75 FPM	Dodge	20 / 19	20 / 19	20 / 19	20 / 19	n.a.	n.a.
	Grove	20 / 19	20 / 19	20 / 19	20 / 19		
90 FPM	Dodge	19 / 19	19 / 19	19 / 19	19 / 19	n.a.	n.a.
	Grove	19 / 19	19 / 19	19 / 19	19 / 19		
105 FPM	Dodge	22 / 19	22 / 19	22 / 19	22 / 19	n.a.	n.a.
	Grove	22 / 19	22 / 19	22 / 19	22 / 19		
120 FPM	Dodge	19 / 19	19 / 19	19 / 19	19 / 19	19 / 19	n.a.
	Grove	19 / 19	19 / 19	19 / 19	19 / 19	19 / 19	
135 FPM	Dodge	21 / 19	21 / 19	21 / 19	21 / 19	21 / 19	n.a.
	Grove	21 / 19	21 / 19	21 / 19	21 / 19	21 / 19	
150 FPM	Dodge	16 / 19	16 / 19	16 / 19	16 / 19	16 / 19	n.a.
	Grove	16 / 19	16 / 19	16 / 19	16 / 19	16 / 19	
165 FPM	Dodge	17 / 19	17 / 19	17 / 19	17 / 19	17 / 19	17 / 19
	Grove	17 / 19	17 / 19	17 / 19	17 / 19	17 / 19	17 / 19
180 FPM	Dodge	19 / 19	19 / 19	19 / 19	19 / 19	19 / 19	19 / 19
	Grove	19 / 19	19 / 19	19 / 19	19 / 19	19 / 19	19 / 19

For Part Numbers, see Tables I-6 (for Driver Sprocket) or Table I-8 (for Driven Sprocket)

Table I - 27 BUSHING (Driver Sprocket) Model No. - Bore

Speed FPM	Reducer Brand	Power Unit Horsepower							
		.5	.75	1.0	1.5	2.0	3.0	5.0	7.5
FOR SA2000 INTERMEDIATE DRIVE POWER UNITS (TIMING BELT)									
30	Dodge	1210-1.0	1210-1.1	2012-1.3	2012-1.5	n.a.	n.a.	n.a.	n.a.
	Grove	1210-1.1	1210-1.2	2012-1.8	2012-1.8				
45	Dodge	1610-1.0	1610-1.1	1610-1.1	2012-1.3	n.a.	n.a.	n.a.	n.a.
	Grove	2012-1.1	2012-1.1	2012-1.2	2012-1.8				
60	Dodge	1610-0.8	1610-1.0	1610-1.1	1610-1.1	2012-1.3	n.a.	n.a.	n.a.
	Grove	2012-1.1	2012-1.1	2012-1.2	2012-1.8	2012-1.8			
75	Dodge	2012-0.8	2012-1.0	2012-1.1	2012-1.1	2012-1.3	2012-1.5	n.a.	n.a.
	Grove	2012-1.1	2012-1.1	2012-1.1	2012-1.5	2012-1.8	2012-1.8		
90	Dodge	1610-0.8	1610-0.8	1610-1.0	1610-1.1	2012-1.1	2012-1.3	n.a.	n.a.
	Grove	1610-1.0	1610-1.0	1610-1.1	1610-1.1	2012-1.8	2012-1.8		
105	Dodge	1610-0.8	1610-0.8	1610-0.8	1610-1.1	1610-1.1	1610-1.3	n.a.	n.a.
	Grove	1610-1.0	1610-1.0	1610-1.0	1610-1.1	1210-1.2	2517-1.8		
120	Dodge	1610-0.8	1610-0.8	1610-0.8	2012-1.1	2012-1.1	2517-1.3	2012-1.5	n.a.
	Grove	1610-1.0	1610-1.0	1610-1.0	1610-1.2	1610-1.5	5012-1.8	2012-1.8	
135	Dodge	2012-0.8	2012-0.8	2012-0.8	2012-1.1	2012-1.1	2517-1.3	2517-1.5	n.a.
	Grove	2012-1.0	2012-1.0	2012-1.1	2012-1.1	2012-1.2	2517-1.5	2517-1.8	
150	Dodge	1210-0.8	1210-0.8	1210-0.8	1210-1.0	1210-1.1	2517-1.3	2517-1.5	n.a.
	Grove	1210-1.0	1210-1.0	1210-1.0	1210-1.1	1210-1.1	2517-1.5	2517-1.8	
165	Dodge	1610-0.8	1610-0.8	1610-0.8	1610-1.0	1610-1.1	2517-1.3	2517-1.52	n.a.
	Grove	1610-1.0	1610-1.0	1610-1.0	1610-1.1	1610-1.1	2517-1.5	2517-1.8	
180	Dodge	1610-0.8	1610-0.8	1610-0.8	1610-1.0	1610-1.1	1610-1.1	2012-1.3	2012-1.5
	Grove	1610-1.0	1610-1.0	1610-1.0	1610-1.2	1610-1.2	1610-1.2	2517-1.8	2517-1.8
200	Dodge	1210-0.8	1210-0.8	1210-0.8	1210-0.8	1210-1.0	1210-1.1	2517-1.3	2517-1.5
	Grove	1210-1.0	1210-1.0	1210-1.0	1210-1.1	1210-1.1	1210-1.2	2517-1.8	2517-1.8
225	Dodge	1610-0.8	1610-0.8	1610-0.8	1610-0.8	1610-1.0	1610-1.1	1610-1.3	2517-1.5
	Grove	1610-1.0	1610-1.0	1610-1.0	1610-1.1	1610-1.1	1610-1.2	2517-1.5	2517-1.8
250	Dodge	1610-0.8	1610-0.8	1610-0.8	1610-0.8	1610-1.0	1610-1.1	2012-1.3	2012-1.5
	Grove	1610-1.0	1610-1.0	1610-1.0	1610-1.0	2012-1.1	2012-1.2	2517-1.8	2517-1.8
275	Dodge	1108-0.8	1108-0.8	1108-0.8	1108-0.8	1108-0.8	1108-1.1	2517-1.3	2517-1.5
	Grove	1108-1.0	1108-1.0	1108-1.0	1108-1.0	1610-1.2	1610-1.2	2517-1.5	2517-1.8
300	Dodge	1210-0.8	1210-0.8	1210-0.8	1210-0.8	1210-0.8	1210-1.1	2517-1.3	2517-1.5
	Grove	1210-1.0	1210-1.0	1210-1.0	1210-1.0	1210-1.1	1210-1.1	1210-1.2	2517-1.8
325	Dodge	1610-0.8	1610-0.8	1610-0.8	1610-0.8	1610-0.8	1610-1.1	1210-1.1	2517-1.5
	Grove	1610-1.0	1610-1.0	1610-1.0	1610-1.0	1610-1.0	1610-1.1	1610-1.2	2517-1.8
350	Dodge	1610-0.8	1610-0.8	1610-0.8	1610-0.8	1610-0.8	1610-1.1	1610-1.1	2517-1.5
	Grove	1610-1.0	1610-1.0	1610-1.0	1610-1.0	1610-1.0	1610-1.1	1610-1.2	2517-1.8
375	Dodge	1610-0.8	1610-0.8	1610-0.8	1610-0.8	1610-0.8	1610-1.1	1610-1.1	2517-1.5
	Grove	1610-1.0	2012-1.0	2012-1.0	2012-1.0	2012-1.0	2012-1.1	2012-1.2	2517-1.8
400	Dodge	2012-0.8	2012-0.8	2012-0.8	2012-0.8	2012-0.8	2012-1.1	2012-1.1	2517-1.5
	Grove	2012-1.0	2012-1.0	2012-1.0	2012-1.0	2012-1.0	2012-1.1	2012-1.2	2517-1.8
425	Dodge	2012-0.8	2012-0.8	2012-0.8	2012-0.8	2012-0.8	2012-1.1	2012-1.1	2517-1.5
	Grove	2012-1.0	2012-1.0	2012-1.0	2012-1.0	2012-1.1	2012-1.1	2012-1.2	2517-1.8
450	Dodge	2012-0.8	2012-0.8	2012-0.8	2012-0.8	2012-0.8	2012-1.1	2012-1.1	2517-1.5
	Grove	2012-1.0	2012-1.0	2012-1.0	2012-1.0	2012-1.0	2012-1.1	2012-1.2	2517-1.8
475	Dodge	2012-0.8	2012-0.8	2012-0.8	2012-0.8	2012-0.8	2012-1.1	2012-1.1	2517-1.5
	Grove	2012-1.0	2012-1.0	2012-1.0	2012-1.0	2012-1.0	2012-1.1	2012-1.2	2517-1.8
500	Dodge	2012-0.8	2012-0.8	2012-0.8	2012-0.8	2012-0.8	2012-1.1	2012-1.1	2517-1.5
	Grove	2012-1.0	2012-1.0	2012-1.0	2012-1.0	2012-1.0	2012-1.2	2012-1.2	2517-1.8

(*) 0.8 = 0.875"; 1.0 = 1.0"; 1.1 = 1.125"; 1.2 = 1.250"; 1.3 = 1.375"; 1.5 = 1.500"; 1.8 = 1.875" For Part Numbers, see Table I-7

Table I - 27 BUSHING (Driver Sprocket) Model No. - Bore (continued)

Speed FPM	Reducer Brand	Power Unit Horsepower							
		.5	.75	1.0	1.5	2.0	3.0	5.0	7.5
FOR SA2001 Low-Profile INTERMEDIATE DRIVE POWER UNITS (TIMING BELT)									
30	Dodge	1610-1.0	1610-1.1	2517-1.3	n.a.	n.a.	n.a.	n.a.	n.a.
	Grove	1610-1.1	1610-1.2	2517-1.2					
45	Dodge	2012-1.0	2012-1.1	2012-1.1	3020-1.5	n.a.	n.a.	n.a.	n.a.
	Grove	2012-1.0	2012-1.1	2012-1.2					
60	Dodge	1610-1.0	1610-1.0	1610-1.1	1610-1.1	n.a.	n.a.	n.a.	n.a.
	Grove	1610-1.0	1610-1.1	1610-1.1	1610-1.5				
75	Dodge	1610-1.0	1610-1.0	1610-1.0	1610-1.1	1610-1.1	n.a.	n.a.	n.a.
	Grove	1610-1.0	1610-1.0	1610-1.1	1610-1.2	1610-1.5			
90	Dodge	1210-1.0	1210-1.0	1210-1.0	1210-1.1	2012-1.1	n.a.	n.a.	n.a.
	Grove	1210-1.0	1210-1.0	1210-1.1	1210-1.1	2012-1.2			
105	Dodge	1610-1.0	1610-1.0	1610-1.0	1610-1.1	1610-1.1	n.a.	n.a.	n.a.
	Grove	1610-1.0	1610-1.0	1610-1.0	1610-1.1	1610-1.2			
120	Dodge	2012-1.0	2012-1.0	2012-1.0	2012-1.1	2012-1.1	2012-1.3	2517-1.5	n.a.
	Grove	2012-1.0	2012-1.0	2012-1.0	2012-1.1	2012-1.2	2012-1.5	2517-1.8	
135	Dodge	1210-1.0	1210-1.0	1210-1.0	1210-1.0	1210-1.1	2012-1.3	2517-1.5	n.a.
	Grove	1210-1.0	1210-1.0	1210-1.0	1210-1.1	1210-1.1	2012-1.2	2517-1.8	
150	Dodge	1610-1.0	1610-1.0	1610-1.0	1610-1.0	1610-1.1	1610-1.1	2012-1.3	n.a.
	Grove	1610-1.0	1610-1.0	1610-1.0	1610-1.1	1610-1.1	1610-1.2	2012-1.5	
165	Dodge	2012-1.0	2012-1.0	2012-1.0	2012-1.0	2012-1.1	2012-1.1	2517-1.3	n.a.
	Grove	2012-1.0	2012-1.0	2012-1.0	2012-1.0	2012-1.1	2012-1.2	2517-1.5	
180	Dodge	1210-1.0	1210-1.0	1210-1.0	1210-1.0	1210-1.0	1210-1.1	2517-1.3	n.a.
	Grove	1210-1.0	1210-1.0	1210-1.0	1210-1.0	1210-1.1	1210-1.2	2517-1.5	
200	Dodge	1610-1.0	1610-1.0	1610-1.0	1610-1.0	1610-1.0	1610-1.1	2517-1.3	2517-1.5
	Grove	1610-1.0	1610-1.0	1610-1.0	1610-1.0	1610-1.1	1610-1.2	1610-1.5	2517-1.5
225	Dodge	2012-1.0	2012-1.0	2012-1.0	2012-1.0	2012-1.0	2012-1.1	3020-1.3	3020-1.5
	Grove	2012-1.0	2012-1.0	2012-1.0	2012-1.0	2012-1.2	2012-1.2	2012-1.5	3020-1.5
250	Dodge	2012-1.0	2012-1.0	2012-1.0	2012-1.0	2012-1.0	2012-1.1	3020-1.3	3020-1.5
	Grove	2012-1.0	2012-1.0	2012-1.0	2012-1.0	2012-1.2	2012-1.2	2012-1.5	2517-1.8
275	Dodge	1610-1.0	1610-1.0	1610-1.0	1610-1.0	1610-1.0	1610-1.1	1610-1.1	2517-1.5
	Grove	1610-1.0	1610-1.0	1610-1.0	1610-1.0	1610-1.0	1610-1.1	1610-1.2	2517-1.8
300	Dodge	1610-1.0	1610-1.0	1610-1.0	1610-1.0	1610-1.0	1610-1.1	1610-1.1	2012-1.5
	Grove	1610-1.0	1610-1.0	1610-1.0	1610-1.0	1610-1.0	1610-1.1	1610-1.2	3020-1.8
325	Dodge	1610-1.0	1610-1.0	1610-1.0	1610-1.0	1610-1.0	1610-1.1	1610-1.1	2517-1.5
	Grove	1610-1.0	1610-1.0	1610-1.0	1610-1.0	1610-1.0	1610-1.1	1610-1.2	2517-1.8
350	Dodge	2012-1.0	2012-1.0	2012-1.0	2012-1.0	2012-1.0	2012-1.1	2012-1.1	2517-1.5
	Grove	2012-1.0	2012-1.0	2012-1.0	2012-1.0	2012-1.0	2012-1.1	2012-1.2	2012-1.8
375	Dodge	2012-1.0	2012-1.0	2012-1.0	2012-1.0	2012-1.0	2012-1.1	2012-1.1	2517-1.5
	Grove	2012-1.0	2012-1.0	2012-1.0	2012-1.0	2012-1.0	2012-1.1	2012-1.2	2012-1.8
400	Dodge	2012-1.0	2012-1.0	2012-1.0	2012-1.0	2012-1.0	2012-1.1	2012-1.1	2517-1.5
	Grove	2012-1.0	2012-1.0	2012-1.0	2012-1.0	2012-1.0	2012-1.1	2012-1.2	2012-1.8
425	Dodge	2012-1.0	2012-1.0	2012-1.0	2012-1.0	2012-1.0	2012-1.1	2012-1.1	3020-1.5
	Grove	2012-1.0	2012-1.0	2012-1.0	2012-1.0	2012-1.0	2012-1.1	2012-1.2	2012-1.8
450	Dodge	2012-1.0	2012-1.0	2012-1.0	2012-1.0	2012-1.0	2012-1.1	2012-1.1	3020-1.5
	Grove	2012-1.0	2012-1.0	2012-1.0	2012-1.0	2012-1.0	2012-1.1	2012-1.2	2012-1.8
475	Dodge	2012-1.0	2012-1.0	2012-1.0	2012-1.0	2012-1.0	2012-1.1	2012-1.1	3020-1.5
	Grove	2012-1.0	2012-1.0	2012-1.0	2012-1.0	2012-1.0	2012-1.1	2012-1.2	2012-1.8
500	Dodge	1610-1.0	1610-1.0	1610-1.0	1610-1.0	1610-1.0	1610-1.1	1610-1.1	3020-1.5
	Grove	1610-1.0	1610-1.0	1610-1.0	1610-1.0	1610-1.0	1610-1.1	1610-1.2	3020-1.8

(*) 0.8 = 0.875"; 1.0 = 1.0"; 1.1 = 1.125"; 1.2 = 1.250"; 1.3 = 1.375"; 1.5 = 1.500"; 1.8 = 1.875". For Part Numbers, see Table I-7

Table I - 27 BUSHING (Driver Sprocket) Model No. - Bore (continued)

Speed FPM	Reducer Brand	Power Unit Horsepower						
		.5	.75	1.0	1.5	2.0	3.0	5.0
FOR SA2030 / 31 / 32 End DRIVE POWER UNITS (TIMING BELT)								
30	Dodge	1210 - 1.0	n.a.	n.a.	n.a.	n.a.	n.a.	n.a.
	Grove	1210 - 1.1						
45	Dodge	1210 - 1.0	1210 - 1.0	n.a.	n.a.	n.a.	n.a.	n.a.
	Grove	1610 - 1.0						
60	Dodge	1108 - 1.0	1108 - 1.0	1108 - 1.0	n.a.	n.a.	n.a.	n.a.
	Grove	1210 - 1.0	1210 - 1.1	1210 - 1.1				
75	Dodge	1210 - 1.0	1210 - 1.0	1210 - 1.0	1108 - 1.1	n.a.	n.a.	n.a.
	Grove	1210 - 1.0	1210 - 1.1	1210 - 1.1	1210 - 1.1			
90	Dodge	1210 - 1.0	1210 - 1.0	1210 - 1.0	1610 - 1.1	n.a.	n.a.	n.a.
	Grove	1610 - 1.0	1610 - 1.0	1610 - 1.0	1610 - 1.1			
105	Dodge	2012 - 1.0	2012 - 1.0	2012 - 1.0	2012 - 1.1	n.a.	n.a.	n.a.
	Grove	2012 - 1.0	2012 - 1.0	2012 - 1.0	2012 - 1.1			
120	Dodge	1108 - 1.0	1108 - 1.0	1108 - 1.0	1108 - 1.0	1108 - 1.1	n.a.	n.a.
	Grove	1210 - 1.0	1210 - 1.0	1210 - 1.0	1210 - 1.1	1210 - 1.1		
135	Dodge	1210 - 1.0	1210 - 1.0	1210 - 1.0	1210 - 1.0	1610 - 1.1	n.a.	n.a.
	Grove	1610 - 1.0	1610 - 1.0	1610 - 1.0	1610 - 1.0	1610 - 1.1		
150	Dodge	1210 - 1.0	1210 - 1.0	1210 - 1.0	1210 - 1.0	1210 - 1.1	n.a.	n.a.
	Grove	1210 - 1.0	1210 - 1.0	1210 - 1.0	1210 - 1.0	1210 - 1.0		
165	Dodge	1610 - 1.0	1610 - 1.0	1610 - 1.0	1610 - 1.0	1610 - 1.1	1610 - 1.1	n.a.
	Grove	1610 - 1.0	1610 - 1.0	1610 - 1.0	1610 - 1.0	1610 - 1.1	1610 - 1.1	
180	Dodge	1210 - 1.0	1210 - 1.0	1210 - 1.0	1210 - 1.0	1210 - 1.0	1610 - 1.1	n.a.
	Grove	1610 - 1.0	1610 - 1.0	1610 - 1.0	1610 - 1.0	1610 - 1.0	1610 - 1.1	
200	Dodge	1610 - 1.0	1610 - 1.0	1610 - 1.0	1610 - 1.0	1610 - 1.0	1610 - 1.0	n.a.
	Grove	2012 - 1.0	2012 - 1.0	2012 - 1.0	2012 - 1.0	2012 - 1.0	2012 - 1.1	
225	Dodge	2012 - 1.0	2012 - 1.0	2012 - 1.0	2012 - 1.0	2012 - 1.0	2012 - 1.0	n.a.
	Grove	2012 - 1.0	2012 - 1.0	2012 - 1.0	2012 - 1.0	2012 - 1.0	2012 - 1.1	
250	Dodge	1610 - 1.0	1610 - 1.0	1610 - 1.0	1610 - 1.0	1610 - 1.0	1610 - 1.0	n.a.
	Grove	1610 - 1.0	1610 - 1.0	1610 - 1.0	1610 - 1.0	1610 - 1.0	1610 - 1.0	
275	Dodge	1210 - 1.0	1210 - 1.0	1210 - 1.0	1210 - 1.0	1210 - 1.0	1610 - 1.1	1610 - 1.1
	Grove	1610 - 1.0	1610 - 1.0	1610 - 1.0	1610 - 1.0	1610 - 1.0	1610 - 1.0	
300	Dodge	1610 - 1.0	1610 - 1.0	1610 - 1.0	1610 - 1.0	1610 - 1.0	1610 - 1.0	1610 - 1.1
	Grove	2012 - 1.0	2012 - 1.0	2012 - 1.0	2012 - 1.0	2012 - 1.0	2012 - 1.0	
325	Dodge	1610 - 1.0	1610 - 1.0	1610 - 1.0	1610 - 1.0	1610 - 1.0	1610 - 1.0	1610 - 1.1
	Grove	1610 - 1.0	1610 - 1.0	1610 - 1.0	1610 - 1.0	1610 - 1.0	1610 - 1.0	
350	Dodge	1610 - 1.0	1610 - 1.0	1610 - 1.0	1610 - 1.0	1610 - 1.0	2012 - 1.1	2012 - 1.1
	Grove	1610 - 1.0	1610 - 1.0	1610 - 1.0	1610 - 1.0	1610 - 1.0	1610 - 1.0	
375	Dodge	2012 - 1.0	2012 - 1.0	2012 - 1.0	2012 - 1.0	2012 - 1.0	2012 - 1.0	2012 - 1.1
	Grove	2012 - 1.0	2012 - 1.0	2012 - 1.0	2012 - 1.0	2012 - 1.0	2012 - 1.0	
400	Dodge	2012 - 1.0	2012 - 1.0	2012 - 1.0	2012 - 1.0	2012 - 1.0	2012 - 1.0	2012 - 1.1
	Grove	2012 - 1.0	2012 - 1.0	2012 - 1.0	2012 - 1.0	2012 - 1.0	2012 - 1.0	
425	Dodge	2012 - 1.0	2012 - 1.0	2012 - 1.0	2012 - 1.0	2012 - 1.0	2012 - 1.0	2012 - 1.1
	Grove	2012 - 1.0	2012 - 1.0	2012 - 1.0	2012 - 1.0	2012 - 1.0	2012 - 1.0	
450	Dodge	2012 - 1.0	2012 - 1.0	2012 - 1.0	2012 - 1.0	2012 - 1.0	2012 - 1.0	2012 - 1.1
	Grove	2012 - 1.0	2012 - 1.0	2012 - 1.0	2012 - 1.0	2012 - 1.0	2012 - 1.0	
475	Dodge	2012 - 1.0	2012 - 1.0	2012 - 1.0	2012 - 1.0	2012 - 1.0	2012 - 1.0	2012 - 1.1
	Grove	2012 - 1.0	2012 - 1.0	2012 - 1.0	2012 - 1.0	2012 - 1.0	2012 - 1.0	
500	Dodge	2012 - 1.0	2012 - 1.0	2012 - 1.0	2012 - 1.0	2012 - 1.0	2012 - 1.0	2012 - 1.1
	Grove	2012 - 1.0	2012 - 1.0	2012 - 1.0	2012 - 1.0	2012 - 1.0	2012 - 1.0	

(*) 0.8 = 0.875"; 1.0 = 1.0"; 1.1 = 1.125"; 1.2 = 1.250"; 1.3 = 1.375"; 1.5 = 1.500"

For Part Numbers, see Table I-7

Table I - 28 BUSHING (Driver Sprocket) Model No. - Bore

Conveyor Speed	Reducer Brand	Power Unit Horsepower					
		.5	.75	1.0	1.5	2.0	3.0
FOR SA2000 INTERMEDIATE DRIVE POWER UNITS (CHAIN-DRIVE)							
30 FPM	Dodge	1610-1.1	1610-1.1	1610-1.3	1610-1.5	n.a.	n.a.
	Grove	1610-1.1	1610-1.2	1610-1.2	1610-1.5		
45 FPM	Dodge	2012-1.1	2012-1.1	2012-1.3	1610-1.5	n.a.	n.a.
	Grove	2012-1.1	2012-1.2	2012-1.2	2012-1.5		
60 FPM	Dodge	2012-1.0	2012-1.1	2012-1.1	2012-1.3	1610-1.3	1610-1.5
	Grove	2012-1.0	2012-1.1	2012-1.2	2012-1.5	2012-1.8	2012-1.8
75 FPM	Dodge	2012-1.0	2012-1.1	2012-1.1	2012-1.3	1610-1.3	1610-1.5
	Grove	2012-1.0	2012-1.1	2012-1.2	2012-1.5	2012-1.8	2012-1.8
90 FPM	Dodge	1610-0.8	1610-1.0	1610-1.1	1610-1.1	1610-1.3	1610-1.5
	Grove	2012-1.0	2012-1.1	2012-1.1	2012-1.2	2012-1.5	2012-1.8
105 FPM	Dodge	2012-0.8	2012-1.0	2012-1.1	2012-1.1	2012-1.3	2012-1.5
	Grove	2012-1.0	2012-1.0	2012-1.1	2012-1.2	2012-1.2	2012-1.8
120 FPM	Dodge	2012-0.8	2012-0.8	2012-1.0	2012-1.1	2012-1.1	2012-1.3
	Grove	2012-1.0	2012-1.0	2012-1.0	2012-1.1	2012-1.2	2012-1.5
135 FPM	Dodge	2012-0.8	2012-0.8	2012-1.0	2012-1.1	2012-1.1	2012-1.3
	Grove	2012-1.0	2012-1.0	2012-1.0	2012-1.1	2012-1.2	2012-1.5
150 FPM	Dodge	1610-0.8	1610-0.8	1610-0.8	1610-1.1	1610-1.1	1610-1.3
	Grove	1610-1.0	1610-1.0	1610-1.0	1610-1.1	1610-1.2	1610-1.2
165 FPM	Dodge	2012-0.8	2012-0.8	2012-0.8	2012-1.1	2012-1.1	2012-1.3
	Grove	2012-1.0	2012-1.0	2012-1.0	2012-1.1	2012-1.2	2012-1.2
180 FPM	Dodge	2012-0.8	2012-0.8	2012-0.8	2012-1.1	2012-1.1	2012-1.3
	Grove	2012-1.0	2012-1.0	2012-1.0	2012-1.1	2012-1.2	2012-1.2
FOR SA2001 Low-Profile INTERMEDIATE DRIVE POWER UNITS (CHAIN DRIVE)							
30 FPM	Dodge	1610-1.0	1610-1.1	1610-1.1	n.a.	n.a.	n.a.
	Grove	1610-1.0	1610-1.1	1610-1.2			
45 FPM	Dodge	1610-1.0	1610-1.1	1610-1.1	1610-1.3	n.a.	n.a.
	Grove	1610-1.0	1610-1.1	1610-1.2	1610-1.5		
60 FPM	Dodge	1610-1.0	1610-1.0	1610-1.1	1610-1.1	1610-1.3	n.a.
	Grove	2012-1.0	2012-1.1	2012-1.2	2012-1.5	2012-1.8	
75 FPM	Dodge	1610-1.0	1610-1.0	1610-1.1	1610-1.1	1610-1.3	1610-1.5
	Grove	2012-1.0	2012-1.1	2012-1.1	2012-1.2	2012-1.5	2012-1.8
90 FPM	Dodge	1610-1.0	1610-1.0	1610-1.0	1610-1.1	1610-1.1	1610-1.3
	Grove	2012-1.0	2012-1.0	2012-1.1	2012-1.2	2012-1.2	2012-1.8
105 FPM	Dodge	1610-1.0	1610-1.0	1610-1.0	1610-1.1	1610-1.1	1610-1.3
	Grove	1610-1.0	1610-1.0	1610-1.0	1610-1.1	1610-1.2	1610-1.2
120 FPM	Dodge	1610-1.0	1610-1.0	1610-1.0	1610-1.1	1610-1.1	1610-1.3
	Grove	1610-1.0	1610-1.0	1610-1.0	1610-1.1	1610-1.2	1610-1.2
135 FPM	Dodge	2012-1.0	2012-1.0	2012-1.0	2012-1.1	2012-1.1	2012-1.3
	Grove	2012-1.0	2012-1.0	2012-1.0	2012-1.1	2012-1.2	2012-1.2
150 FPM	Dodge	2012-1.0	2012-1.0	2012-1.0	2012-1.1	2012-1.1	2012-1.3
	Grove	2012-1.0	2012-1.0	2012-1.0	2012-1.1	2012-1.2	2012-1.2
165 FPM	Dodge	2012-1.0	2012-1.0	2012-1.0	2012-1.1	2012-1.1	2012-1.3
	Grove	2012-1.0	2012-1.0	2012-1.0	2012-1.1	2012-1.2	2012-1.2
180 FPM	Dodge	2012-1.0	2012-1.0	2012-1.0	2012-1.1	2012-1.1	2012-1.3
	Grove	2012-1.0	2012-1.0	2012-1.0	2012-1.0	2012-1.1	2012-1.2

(*) 1.0 = 1.0"; 1.1 = 1.125"; 1.2 = 1.250"; 1.3 = 1.375"; 1.5 = 1.500"; 1.8 = 1.875"

Table I - 28 BUSHING (Driver Sprocket) Model No. - Bore (continued)

Conveyor Speed	Reducer Brand	Power Unit Horsepower					
		.5	.75	1.0	1.5	2.0	3.0
FOR SA2030/31/32 END DRIVE (4" Dia. Pulley) POWER UNITS (CHAIN-DRIVE)							
30 FPM	Dodge	1610-1.0	1610-1.1	n.a.	n.a.	n.a.	n.a.
	Grove	1610-1.0	n.a.				
45 FPM	Dodge	1610-1.0	1610-1.1	n.a.	n.a.	n.a.	n.a.
	Grove	1610-1.0	1610-1.1				
60 FPM	Dodge	1610-1.0	1610-1.0	1610-1.1	n.a.	n.a.	n.a.
	Grove	1610-1.0	1610-1.1	1610-1.1			
75 FPM	Dodge	1610-1.0	1610-1.0	1610-1.1	1610-1.1	n.a.	n.a.
	Grove	1610-1.0	1610-1.0	1610-1.1	1610-1.2		
90 FPM	Dodge	1610-1.0	1610-1.0	1610-1.0	1610-1.1	n.a.	n.a.
	Grove	1610-1.0	1610-1.0	1610-1.0	1610-1.1		
105 FPM	Dodge	1610-1.0	1610-1.0	1610-1.0	1610-1.1	n.a.	n.a.
	Grove	1610-1.0	1610-1.0	1610-1.0	1610-1.1		
120 FPM	Dodge	1610-1.0	1610-1.0	1610-1.0	1610-1.1	1610-1.1	n.a.
	Grove	1610-1.0	1610-1.0	1610-1.0	1610-1.1	1610-1.2	
135 FPM	Dodge	1610-1.0	1610-1.0	1610-1.0	1610-1.1	1610-1.1	n.a.
	Grove	1610-1.0	1610-1.0	1610-1.0	1610-1.1	1610-1.2	
150 FPM	Dodge	1610-1.0	1610-1.0	1610-1.0	1610-1.0	1610-1.1	n.a.
	Grove	1610-1.0	1610-1.0	1610-1.0	1610-1.0	1610-1.1	
165 FPM	Dodge	1610-1.0	1610-1.0	1610-1.0	1610-1.1	1610-1.1	n.a.
	Grove	1610-1.0	1610-1.0	1610-1.0	1610-1.0	1610-1.1	
180 FPM	Dodge	1610-1.0	1610-1.0	1610-1.0	1610-1.0	1610-1.1	1610-1.1
	Grove	1610-1.0	1610-1.0	1610-1.0	1610-1.0	1610-1.1	1610-1.2

(*) 1.0 = 1.0"; 1.1 = 1.125"; 1.2 = 1.250"

Table I - 29 Timing Belt (Length / Width (mm))

Speed FPM	Reducer Brand	Power Unit Horsepower							
		.5	.75	1.0	1.5	2.0	3.0	5.0	7.5
FOR SA2000 INTERMEDIATE DRIVE POWER UNITS									
30	Dodge	1200 / 21	1200 / 21	1400 / 37	1400 / 37	n.a.	n.a.	n.a.	n.a.
	Grove	1200 / 21	1200 / 21	1400 / 34	1400 / 37				
45	Dodge	1210 / 21	1280 / 21	1280 / 36	1400 / 37	n.a.	n.a.	n.a.	n.a.
	Grove	1280 / 21	1280 / 21	1280 / 36	1400 / 37				
60	Dodge	1200 / 21	1200 / 21	1280 / 21	1280 / 36	1400 / 37	n.a.	n.a.	n.a.
	Grove	1280 / 21	1280 / 21	1280 / 36	1400 / 37	1400 / 37			
75	Dodge	1200 / 21	1200 / 21	1280 / 21	1280 / 36	1280 / 36	1280 / 36	n.a.	n.a.
	Grove	1280 / 21	1280 / 21	1280 / 21	1280 / 36	1400 / 37	1400 / 37		
90	Dodge	1200 / 21	1200 / 21	1200 / 21	1280 / 36	1400 / 37	1400 / 37	n.a.	n.a.
	Grove	1200 / 21	1200 / 21	1200 / 21	1200 / 36	1400 / 37	1400 / 37		
105	Dodge	1200 / 21	1200 / 21	1200 / 21	1200 / 21	1200 / 36	1280 / 36	n.a.	n.a.
	Grove	1200 / 21	1200 / 21	1200 / 21	1200 / 21	1280 / 36	1400 / 37		
120	Dodge	1200 / 21	1200 / 21	1200 / 21	1280 / 21	1280 / 36	1400 / 37	1400 / 37	n.a.
	Grove	1200 / 21	1200 / 21	1200 / 21	1200 / 21	1280 / 36	1400 / 37	1400 / 37	
135	Dodge	1200 / 21	1200 / 21	1200 / 21	1280 / 36	1280 / 36	1400 / 37	1400 / 37	n.a.
	Grove	1280 / 21	1280 / 21	1280 / 21	1280 / 21	1280 / 36	1400 / 37	1400 / 37	
150	Dodge	1200 / 21	1200 / 21	1200 / 21	1200 / 21	1200 / 36	1400 / 37	1400 / 34	n.a.
	Grove	1200 / 21	1200 / 21	1200 / 21	1200 / 21	1200 / 36	1400 / 37	1400 / 37	
165	Dodge	1200 / 21	1200 / 21	1200 / 21	1200 / 21	1200 / 21	1400 / 37	1400 / 37	n.a.
	Grove	1200 / 21	1200 / 21	1200 / 21	1200 / 21	1200 / 36	1400 / 37	1400 / 37	
180	Dodge	1200 / 21	1200 / 21	1200 / 21	1200 / 21	1280 / 21	1280 / 36	1400 / 37	1400 / 37
	Grove	1200 / 21	1200 / 21	1200 / 21	1280 / 21	1280 / 21	1280 / 36	1400 / 37	1400 / 37
200	Dodge	1200 / 21	1200 / 21	1200 / 21	1200 / 21	1200 / 21	1280 / 36	1400 / 37	1400 / 37
	Grove	1200 / 21	1200 / 21	1200 / 21	1200 / 21	1200 / 21	1200 / 36	1400 / 37	1400 / 37
225	Dodge	1200 / 21	1200 / 21	1200 / 21	1200 / 21	1200 / 21	1200 / 36	1280 / 36	1400 / 37
	Grove	1200 / 21	1200 / 21	1200 / 21	1200 / 21	1200 / 21	1200 / 36	1400 / 37	1400 / 37
250	Dodge	1200 / 21	1200 / 21	1200 / 21	1200 / 21	1200 / 21	1200 / 36	1400 / 37	1400 / 37
	Grove	1200 / 21	1200 / 21	1200 / 21	1200 / 21	1200 / 21	1280 / 21	1400 / 37	1400 / 37
275	Dodge	1200 / 21	1200 / 21	1200 / 21	1200 / 21	1200 / 21	1200 / 21	1400 / 37	1400 / 37
	Grove	1200 / 21	1200 / 21	1200 / 21	1200 / 21	1200 / 21	1200 / 21	1400 / 37	1400 / 37
300	Dodge	1200 / 21	1200 / 21	1200 / 21	1200 / 21	1200 / 21	1200 / 21	1400 / 37	1400 / 37
	Grove	1200 / 21	1200 / 21	1200 / 21	1200 / 21	1200 / 21	1200 / 21	1200 / 36	1400 / 37
325	Dodge	1200 / 21	1200 / 21	1200 / 21	1200 / 21	1200 / 21	1200 / 21	1200 / 36	1400 / 37
	Grove	1200 / 21	1200 / 21	1200 / 21	1200 / 21	1200 / 21	1200 / 21	1200 / 21	1400 / 37
350	Dodge	1200 / 21	1200 / 21	1200 / 21	1200 / 21	1200 / 21	1280 / 21	1280 / 36	1400 / 37
	Grove	1200 / 21	1200 / 21	1200 / 21	1200 / 21	1200 / 21	1200 / 21	1280 / 21	1400 / 37
375	Dodge	1200 / 21	1200 / 21	1200 / 21	1200 / 21	1200 / 21	1200 / 21	1200 / 36	1400 / 37
	Grove	1200 / 21	1200 / 21	1200 / 21	1200 / 21	1200 / 21	1280 / 21	1280 / 21	1400 / 37
400	Dodge	1200 / 21	1200 / 21	1200 / 21	1200 / 21	1200 / 21	1280 / 21	1280 / 21	1400 / 37
	Grove	1280 / 21	1280 / 21	1280 / 21	1280 / 21	1280 / 21	1280 / 21	1280 / 21	1400 / 37
425	Dodge	1280 / 21	1280 / 21	1280 / 21	1280 / 21	1280 / 21	1280 / 21	1280 / 21	1400 / 37
	Grove	1280 / 21	1280 / 21	1280 / 21	1280 / 21	1280 / 21	1280 / 21	1280 / 21	1400 / 37
450	Dodge	1280 / 21	1280 / 21	1280 / 21	1280 / 21	1280 / 21	1280 / 21	1280 / 21	1400 / 37
	Grove	1280 / 21	1280 / 21	1280 / 21	1280 / 21	1280 / 21	1280 / 21	1280 / 21	1400 / 37
475	Dodge	1280 / 21	1280 / 21	1280 / 21	1280 / 21	1280 / 21	1280 / 21	1280 / 21	1400 / 37
	Grove	1280 / 21	1280 / 21	1280 / 21	1280 / 21	1280 / 21	1280 / 21	1280 / 21	1400 / 37
500	Dodge	1200 / 21	1200 / 21	1200 / 21	1200 / 21	1200 / 21	1280 / 21	1280 / 21	1400 / 37
	Grove	1200 / 21	1200 / 21	1200 / 21	1200 / 21	1200 / 21	1280 / 21	1280 / 36	1400 / 37

I - 29 Timing Belt (Length / Width (mm) (continued)

Speed FPM	Reducer Brand	Power Unit Horsepower							
		.5	.75	1.0	1.5	2.0	3.0	5.0	7.5
FOR SA2001 Low Profile INTERMEDIATE DRIVE POWER UNITS									
30	Dodge	1000 / 21	1000 / 36	1190 / 37	n.a.	n.a.	n.a.	n.a.	n.a.
	Grove	1000 / 21	1000 / 36	1190/37					
45	Dodge	1000 / 21	1000 / 21	1000 / 36	1260 / 37	n.a.	n.a.	n.a.	n.a.
	Grove	1000 / 21	1000 / 21	1000 / 36	1260 / 37				
60	Dodge	1000 / 21	1000 / 21	1000 / 21	1000 / 36	n.a.	n.a.	n.a.	n.a.
	Grove	1000 / 21	1000 / 21	1000 / 21	1000 / 36	1190 / 37			
75	Dodge	1000 / 21	1000 / 21	1000 / 21	1000 / 36	1000 / 36	n.a.	n.a.	n.a.
	Grove	1000 / 21	1000 / 21	1000 / 21	1000 / 36	1000 / 36	1260 / 37		
90	Dodge	1000 / 21	1000 / 21	1000 / 21	1000 / 21	1000 / 36	n.a.	n.a.	n.a.
	Grove	1000 / 21	1000 / 21	1000 / 21	1000 / 21	1000 / 36	1190 / 37		
105	Dodge	1000 / 21	1000 / 21	1000 / 21	1000 / 21	1000 / 36	n.a.	n.a.	n.a.
	Grove	1000 / 21	1000 / 21	1000 / 21	1000 / 21	1000 / 36	1190 / 37		
120	Dodge	1000 / 21	1000 / 21	1000 / 21	1000 / 21	1000 / 21	1000 / 36	1190 / 37	n.a.
	Grove	1000 / 21	1000 / 21	1000 / 21	1000 / 21	1000 / 36	1000 / 36	1260 / 37	
135	Dodge	1000 / 21	1000 / 21	1000 / 21	1000 / 21	1000 / 21	1000 / 36	1260 / 37	n.a.
	Grove	1000 / 21	1000 / 21	1000 / 21	1000 / 21	1000 / 21	1000 / 21	1260 / 37	
150	Dodge	1000 / 21	1000 / 21	1000 / 21	1000 / 21	1000 / 21	1000 / 36	1190 / 37	n.a.
	Grove	1000 / 21	1000 / 21	1000 / 21	1000 / 21	1000 / 21	1000 / 36	1190 / 37	
165	Dodge	1000 / 21	1000 / 21	1000 / 21	1000 / 21	1000 / 21	1000 / 36	1190 / 37	n.a.
	Grove	1000 / 21	1000 / 21	1000 / 21	1000 / 21	1000 / 21	1000 / 36	1190 / 37	
180	Dodge	1000 / 21	1000 / 21	1000 / 21	1000 / 21	1000 / 21	1000 / 36	1190 / 37	n.a.
	Grove	1000 / 21	1000 / 21	1000 / 21	1000 / 21	1000 / 21	1000 / 36	1190 / 37	
200	Dodge	1000 / 21	1000 / 21	1000 / 21	1000 / 21	1000 / 21	1000 / 21	1190 / 37	1190 / 37
	Grove	1000 / 21	1000 / 21	1000 / 21	1000 / 21	1000 / 21	1000 / 21	1000 / 36	1190 / 37
225	Dodge	1000 / 21	1000 / 21	1000 / 21	1000 / 21	1000 / 21	1000 / 21	1260 / 37	1260 / 37
	Grove	1000 / 21	1000 / 21	1000 / 21	1000 / 21	1000 / 21	1000 / 21	1000 / 36	1190 / 37
250	Dodge	1000 / 21	1000 / 21	1000 / 21	1000 / 21	1000 / 21	1000 / 21	1260 / 37	1260 / 37
	Grove	1000 / 21	1000 / 21	1000 / 21	1000 / 21	1000 / 21	1000 / 21	1000 / 36	1190 / 37
275	Dodge	1000 / 21	1000 / 21	1000 / 21	1000 / 21	1000 / 21	1000 / 21	1000 / 36	1260 / 37
	Grove	1000 / 21	1000 / 21	1000 / 21	1000 / 21	1000 / 21	1000 / 21	1000 / 36	1190 / 37
300	Dodge	1000 / 21	1000 / 21	1000 / 21	1000 / 21	1000 / 21	1000 / 21	1000 / 36	1190 / 37
	Grove	1000 / 21	1000 / 21	1000 / 21	1000 / 21	1000 / 21	1000 / 21	1000 / 36	1190 / 37
325	Dodge	1000 / 21	1000 / 21	1000 / 21	1000 / 21	1000 / 21	1000 / 21	1000 / 36	1190 / 37
	Grove	1000 / 21	1000 / 21	1000 / 21	1000 / 21	1000 / 21	1000 / 21	1000 / 36	1190 / 37
350	Dodge	1000 / 21	1000 / 21	1000 / 21	1000 / 21	1000 / 21	1000 / 21	1000 / 36	1190 / 37
	Grove	1000 / 21	1000 / 21	1000 / 21	1000 / 21	1000 / 21	1000 / 21	1000 / 21	1120 / 36
375	Dodge	1000 / 21	1000 / 21	1000 / 21	1000 / 21	1000 / 21	1000 / 21	1000 / 36	1190 / 37
	Grove	1000 / 21	1000 / 21	1000 / 21	1000 / 21	1000 / 21	1000 / 21	1000 / 21	1120 / 36
400	Dodge	1000 / 21	1000 / 21	1000 / 21	1000 / 21	1000 / 21	1000 / 21	1000 / 36	1190 / 37
	Grove	1000 / 21	1000 / 21	1000 / 21	1000 / 21	1000 / 21	1000 / 21	1000 / 21	1120 / 36
425	Dodge	1000 / 21	1000 / 21	1000 / 21	1000 / 21	1000 / 21	1000 / 21	1000 / 36	1260 / 37
	Grove	1000 / 21	1000 / 21	1000 / 21	1000 / 21	1000 / 21	1000 / 21	1000 / 21	1120 / 36
450	Dodge	1000 / 21	1000 / 21	1000 / 21	1000 / 21	1000 / 21	1000 / 21	1000 / 36	1260 / 37
	Grove	1000 / 21	1000 / 21	1000 / 21	1000 / 21	1000 / 21	1000 / 21	1000 / 21	1120 / 36
475	Dodge	1000 / 21	1000 / 21	1000 / 21	1000 / 21	1000 / 21	1000 / 21	1000 / 36	1260 / 37
	Grove	1000 / 21	1000 / 21	1000 / 21	1000 / 21	1000 / 21	1000 / 21	1000 / 21	1000 / 36
500	Dodge	896 / 21	896 / 21	896 / 21	896 / 21	896 / 21	896 / 36	896 / 36	1260 / 37
	Grove	896 / 21	896 / 21	896 / 21	896 / 21	896 / 21	896 / 21	896 / 36	1190 / 37

Table I - 29 Timing Belt (Length / Width (mm) (continued)

Speed FPM	Reducer Brand	Power Unit Horsepower						
		.5	.75	1.0	1.5	2.0	3.0	5.0
FOR SA2030 / 31 32 END DRIVE POWER UNITS								
30	Dodge	1200 / 21	n.a.	n.a.	n.a.	n.a.	n.a.	n.a.
	Grove	1280 / 21						
45	Dodge	1200 / 21	1200 / 21	n.a.	n.a.	n.a.	n.a.	n.a.
	Grove	1200 / 21						
60	Dodge	1200 / 21	1200 / 21	1200 / 21	n.a.	n.a.	n.a.	n.a.
	Grove	1200 / 21						
75	Dodge	1200 / 21	1200 / 21	1200 / 21	1200 / 21	n.a.	n.a.	n.a.
	Grove	1200 / 21						
90	Dodge	1200 / 21	1200 / 21	1200 / 21	1280 / 21	n.a.	n.a.	n.a.
	Grove	1200 / 21						
105	Dodge	1280 / 21	1280 / 21	1280 / 21	1280 / 21	n.a.	n.a.	n.a.
	Grove	1280 / 21						
120	Dodge	1200 / 21	1200 / 21	1200 / 21	1200 / 21	1280 / 21	n.a.	n.a.
	Grove	1200 / 21						
135	Dodge	1200 / 21	1200 / 21	1200 / 21	1200 / 21	1280 / 21	n.a.	n.a.
	Grove	1280 / 21						
150	Dodge	1200 / 21	1200 / 21	1200 / 21	1200 / 21	1200 / 21	n.a.	n.a.
	Grove	1200 / 21						
165	Dodge	1200 / 21	1200 / 21	1200 / 21	1200 / 21	1280 / 21	1280 / 21	n.a.
	Grove	1200 / 21						
180	Dodge	1200 / 21	1200 / 21	1200 / 21	1200 / 21	1200 / 21	1280 / 21	n.a.
	Grove	1200 / 21						
200	Dodge	1280 / 21	1280 / 21	1280 / 21	1280 / 21	1280 / 21	1280 / 21	n.a.
	Grove	1280 / 21						
225	Dodge	1280 / 21	1280 / 21	1280 / 21	1280 / 21	1280 / 21	1280 / 21	n.a.
	Grove	1280 / 21						
250	Dodge	1280 / 21	1280 / 21	1280 / 21	1280 / 21	1280 / 21	1280 / 21	n.a.
	Grove	1280 / 21						
275	Dodge	1200 / 21	1200 / 21	1200 / 21	1200 / 21	1200 / 21	1280 / 21	1280 / 21
	Grove	1200 / 21						
300	Dodge	1200 / 21	1200 / 21	1200 / 21	1200 / 21	1200 / 21	1280 / 21	1280 / 21
	Grove	1280 / 21						
325	Dodge	1200 / 21	1200 / 21	1200 / 21	1200 / 21	1200 / 21	1280 / 21	1280 / 21
	Grove	1200 / 21						
350	Dodge	1200 / 21	1200 / 21	1200 / 21	1200 / 21	1200 / 21	1280 / 21	1280 / 21
	Grove	1200 / 21						
375	Dodge	1200 / 21	1200 / 21	1200 / 21	1200 / 21	1200 / 21	1280 / 21	n.a.
	Grove	1280 / 21						
400	Dodge	1280 / 21	1280 / 21	1280 / 21	1280 / 21	1280 / 21	1280 / 21	1280 / 21
	Grove	1200 / 21						
425	Dodge	1280 / 21	1280 / 21	1280 / 21	1280 / 21	1280 / 21	1280 / 21	1280 / 21
	Grove	1280 / 21						
450	Dodge	1280 / 21	1280 / 21	1280 / 21	1280 / 21	1280 / 21	1280 / 21	1280 / 21
	Grove	1200 / 21						
475	Dodge	1280 / 21	1280 / 21	1280 / 21	1280 / 21	1280 / 21	1280 / 21	1280 / 21
	Grove	1280 / 21						
500	Dodge	1280 / 21	1280 / 21	1280 / 21	1280 / 21	1280 / 21	1280 / 21	1280 / 21
	Grove	1280 / 21						

